

EclerNet Manager (v6.01r4 – MAY 2021)

SOFTWARE

EclerNet Software Application



USER MANUAL

INDEX

1. RELEASE NOTES	7
2. INTRODUCTION	9
3. MENUS AND TOOLBAR	10
3.1. File Menu.....	10
3.2. Edit Menu	10
3.3. View Menu.....	16
3.4. Help Menu	17
3.5. The toolbar	17
4. APPLICATION WINDOWS	18
4.1. Available windows.....	18
4.2. Device Groups display windows:	19
4.3. Channel Groups display windows:	20
4.4. Graphic/table display modes.....	26
5. CONTEXT MENU: RIGHT MOUSE BUTTON	28
5.1. Device context menu:.....	28
5.2. Channel context menu:.....	29
5.3. Device Group context menu:.....	30
5.4. Channel Group context menu:.....	31
6. EclerNet PROJECT	32
6.1. Creating an EclerNet Project.....	33
6.1.1. Opening of a new file.....	33
6.1.2. Insertion of new devices in the Project	34
6.1.3. Creating a device group.....	36
6.1.4. Creating a channel group	39
6.1.5. Identification of networked devices	42
6.1.6. Connecting the device.....	46
6.2. Customizing an EclerNet Project.....	48

7. EclerNet PROJECT CONTROLS AND INDICATORS	50
7.1. Reduced view	50
7.2. Detailed view	53
7.2.1. Vertical range:.....	58
7.2.2. Filled curves (Solid):	59
7.3. Types of control	59
7.3.1. Adjustment potentiometers.....	59
7.3.2. Channel Fader.....	60
7.3.3. Buttons.....	60
7.3.4. Selectors	60
7.3.5. Numerical values.....	60
7.4. Table of status monitoring and alarm icons.....	61
8. COMPATIBLE DEVICES: amplifiers / digital audio managers	63
8.1. NPA and NZA amplifiers series	63
8.1.1. NPA and NZA series detailed view.....	63
8.1.2. INPUT	74
8.1.3. CROSSOVER.....	75
8.1.4. PARAMETRIC EQ.....	75
8.1.5. COMPRESSOR.....	76
8.1.6. DELAY	79
8.1.7. Copying and pasting settings between channels.....	79
8.2 NXA series, self-powered digital audio manager.....	80
8.2.1. Introduction to NXA series.....	80
8.2.2. NXA Series detailed view, general sections of the device	82
8.2.3. NXA series detailed view, device channels	96

9. EclerNet COMPATIBLE DEVICES: MIMO series digital matrixes.....	104
9.1. MIMO88 digital matrix	104
9.1.1. MIMO88 introduction.....	104
9.1.2. 8x8 and 16x16 setups	106
9.1.3. MIMO88 device detailed view	109
9.1.4. MIMO88 general section	112
9.1.5. MIMO88 INPUTS section	116
9.1.6. MIMO88 MATRIX section (I/O matrix).....	124
9.1.7. MIMO88 OUTPUTS section.....	131
9.1.8. MIMO88 PAGERS/DUCKERS section	139
9.1.9. MIMO88 GPIs/GPOs section	146
9.1.10. MIMO88 REMOTES section.....	150
9.1.11. Carousel lists for MIMO88.....	189
9.1.12. MIMO88 EVENTS section.....	193
9.2. MIMO88 CONFERENCE digital matrix	213
9.2.1. MIMO88 CONFERENCE Introduction.....	213
9.2.2. MIMO88 CONFERENCE Firmware Update	215
9.2.3. INPUTS Section and FREQUENCY SHIFTER function.....	218
9.2.4. MATRIX Section	219
9.2.5. OUTPUTS Section	221
9.2.6. DUCKERS Section	223
9.2.7. AUTOMIXER Section	224
9.2.8. FEEDBACK KILLER Section.....	228
9.3. MIMO88SG and MIMO1212SG matrixes	231
9.4. MIMO4040CDN / MIMO7272DN Dante™ matrixes.....	232
9.4.1. MIMO7272DN Dante digital audio features	235
9.4.2. MIMO7272DN Pager / Ducker priority modules.....	250
9.4.3. MIMO4040DN NTP synchronisation service	251
9.4.4. MIMO7272DN UCP (User Control Panels) server service	252
9.4.5. MIMO7272DN REMOTES section.....	258

9.5 MIMO4040CDN (C = CONFERENCE), Dante™ matrix for conference with AEC273	
9.5.1. MIMO4040CDN Introduction.....	273
9.5.2. AEC License Activation.....	275
9.5.3. AEC Section (Acoustic Echo Cancelling)	277
9.5.4. DUCKERS Section	292
9.5.5. AUTOMIXER Section	293
9.5.7. FEEDBACK KILLER Section.....	297
10. EclerNet COMPATIBLE DEVICES: Audio Players	300
10.1. DUO-NET PLAYER	300
10.1.1. Introduction to DUO-NET PLAYER, Dual Streaming Receiver & Media Audio Player.....	300
10.1.2. DUO-NET PLAYER detailed view, general section of the device	301
10.1.3. DUO-NET DEVICE section	304
10.1.4. DUO-NET PLAYER A and PLAYER B sections	307
10.1.5. DUO-NET PRIORITY 1 and PRIORITY 2 modules sections	312
10.1.6. DUO-NET PLAYLIST BANK section	315
10.1.7. DUO-NET EVENTS section.....	323
10.1.8. DUO-NET UCP controls.....	333
11. EclerNet COMPATIBLE DEVICES: DANTE© protocol compatible devices	341
11.1. DN44BOB.....	341
11.1.1. DN44BOB introduction.....	341
11.1.2. DN44BOB device detailed view, general section	342
11.1.3. DN44BOB ANALOGUE AUDIO INPUTS section	349
11.1.4. DN44BOB ANALOGUE AUDIO OUTPUTS section.....	350
11.1.5. DN44BOB DANTE routing.....	351

12. EclerNet COMPATIBLE DEVICES: Video Over IP Extenders and Matrixes	355
12.1. VEO-XTI2L and VEO-XRI2L.....	355
12.1.1 Introduction.....	355
12.1.2. Device discovery.....	356
12.1.3. VEO-XTI2L Settings.....	357
12.1.4. VEO-XRI2L Settings.....	359
12.1.5. UCP control features.....	363
13. USER CONTROL PANELS (U.C.P.)	365
13.1. Introduction	365
13.2. Creating UCPs.....	367
13.3. Functions assignment in the UCP.....	378
13.4. Management of UCP from remote devices.....	389
13.5. EclerNet Manager "hidden" mode and direct access to projects and UCPs....	392
13.6. Error Message from the web server service.....	396
14. WPNETTOUCH DEVICE	398
14.1. Introduction	398
14.2. Local Configuration of the Unit.....	400
14.2.1 Screen Configuration menu	401
14.2.2. Device Configuration menu.....	403
14.2.3. Network Configuration menu.....	405
14.2.4. Information / Tools menu.....	406
14.3. Connection to a UCP Server ("Connect to..." menu).....	408
14.4. Unit Configuration from EclerNet Manager.....	410
14.5. WPNETTOUCH as a UCP Server.....	414

1. RELEASE NOTES

The current version of EclerNet Manager, at the time of writing this document ([v6.01r4](#)), includes many improvements and modifications to make EclerNet platform more solid and reliable, as well as these new features:

- Project & UCP web server supporting HTML5 format, as Adobe Flash support was discontinued in most web browsers on January 2021
- MIMO4040DN CONFERENCE / MIMO4040CDN version support, including Acoustic Echo Cancelling feature (AEC)
- Support for the new MIMO7272DN device (8x8 analog inputs / outputs + 64x64 Dante input / output ports)
- New flexible audio Inputs / Outputs routing for the MIMO4040DN and MIMO4040DN CONFERENCE (MIMO4040CDN) and MIMO7272DN matrixes, based on Input and Output Ports
- New tooltips system for inputs and outputs routing information in the MIMO4040DN, MIMO4040CDN and MIMO7272DN matrixes
- Virtual controls management from TP-NET protocol for all MIMO matrixes
- Several UCP buttons can be stacked graphically on the screen, to allow for a batch of actions with a single click on the upper (visible) button
- Digital events can be triggered by automatic audio signal detection, using a DUCKER module as a trigger options in them (now available for MIMO4040DN, MIMO4040CDN and MIMO7272DN so far, and for the rest of MIMO models in the near future)
- UCP panel page scrolling methods can be completely disabled, to create a closed or guided panels' browsing structure, just using PAGE LINK buttons (jumps among UCP pages inside a panel)
- Secure mode included in UCPs, to activate the bottom HOME bar
- New EXTERNAL (or generic) kind of device can be added in an ENM project: it allows to create standard UCP panels that employ NET String buttons to control the EXTERNAL device, an entity that just has an IP address as its property in the project. Just changing this IP address is enough to make the panel valid to control any real external (not EclerNet native) HW device

We encourage you to read this manual and to watch the video tutorials available at our YouTube channel for a complete training concerning the software application and hardware devices it can manage, as well as for full knowledge about EclerNet systems configuration and control.

For more information:

- [Hardware / software User Manuals and software / firmware versions](#)
- [EclerNet Manager YouTube channel](#)

2. INTRODUCTION

EclerNet Manager is the software application that lets users build a digital audio system, including hardware devices from the following product families: NXA Powered digital audio managers, MIMO88, MIMO88SG and MIMO1212SG digital matrixes, MIMO4040DN / MIMO4040CDN and MIMO7272DN Dante™ matrixes, DUO-NET PLAYER, PAGENETDN Dante™ paging console, DN44BOB Dante™ audio interface, WPNET4KV, WPNET8K and WPNETEX digital control wall panels, and WPNETTOUCH / WPmSCREEN screen control interfaces.

Using this software, it's possible to identify every device connected to the network and configure it, together with the digital accessories that can be connected to it, like the WPTOUCH / WPNET digital wall panels and the MPAGE16 / eMPAGE digital paging stations.

Once the project file that stores this configuration is created and stored, the EclerNet Manager application can also include UCPs (User Control Panels), which are graphical control screens, customised for the needs of each remote user.

The EclerNet Manager software (running a project in a computer, a WPNETTOUCH, a WPmSCREEN, a PAGENETDN or a MIMO4040DN / MIMO4040CDN / MIMO7272DN unit) includes a webserver allowing the remote-control devices (WPNETTOUCH, PAGENETDN, WPmSCREEN, Windows® OS computers and tablets, Android® OS tablets and smartphones, iPhones®, iPads®, etc.) become web clients, recalling and managing those UCPs for an end user graphical, custom and friendly control experience.

3. MENUS AND TOOLBAR

Following menus are available in the upper bar of the application window (matching keyboard shortcuts are given inside brackets):

3.1. File Menu

- **New** (ctrl + N): opens a new Project.
- **Open** (ctrl + O): opens a Project stored on a local hard disk or other data storage unit.
- **Save** (ctrl + S): saves the current Project on a local hard disk or other data storage unit.
- **Save As:** a dialog box lets you save the current Project with a different name and/or location.
- **Recent Projects:** displays a list of recently opened Projects and allows you to directly open one of them.
- **Exit:** closes the program.

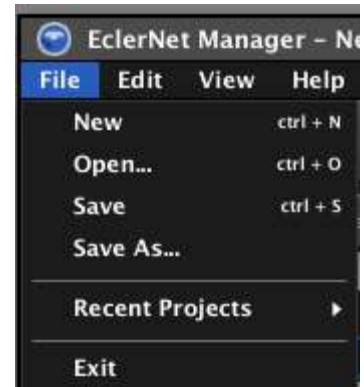

3.2. Edit Menu

- **Add Device:** adds a new device to the current Project.
Parameters:
 - **Device Type:** selects in a list of compatible EclerNet device types the one to add.
 - **Device Name:** allows the new device to be named.
- **Add Multiple Devices:** adds several new devices to the current Project.

Parameters:

- **Device Type:** selects in a list of compatible EclerNet device types the one to add.
- **Number:** number of devices to add.

- **Add Device Group:** opens a dialog box to create a new device group in the current Project.

Parameters:

- **Group Name:** allows the new device group to be named.

Note: you can create a group within a group (see section: 4. EclerNet PROJECT)

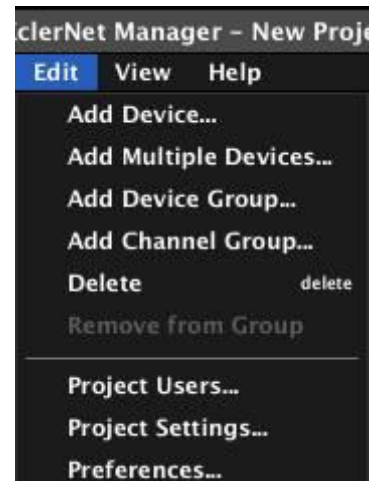

- **Add Channel Group:** opens a dialog box to create a new channel group in the current Project.

Parameters:

- **Group Name:** allows the new channel group to be named.

Note: you can create a group within a group (see section: **4. EclerNet PROJECT**)

- **Delete (Delete key):** allows a device, channel, device group or channel group to be deleted from the Project. In order to remove a component, select it first (by mouse or keyboard) in any application view.
- **Remove from Group:** allows a device to be removed from a device group or a channel to be removed from a channel group. In order to remove a component, select it first (by mouse or keyboard) in any application view.
- **Project Users:** opens the configuration window for users and passwords (also accessible by clicking on the Users button in the toolbar).

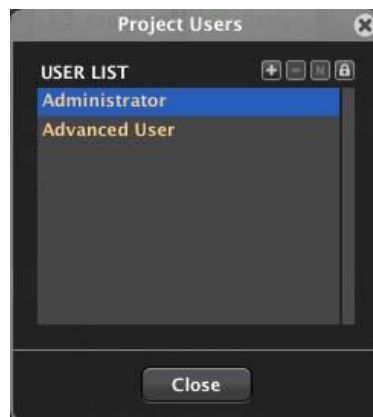

From this window you can create new generic users, delete or rename any existing ones and change passwords for them and for the two default user profiles: **Administrator** and **Advanced User**, which are blank by default. If passwords are assigned to one or another user in a project, when trying to perform certain operations a password is requested in order to be identified as Administrator or Advanced User. Thus, the project remains protected from any structural changes or operations made by users without such privileges that could jeopardize the normal operation of the system.

The following table summarizes the privileges of the three possible user profiles:

	Administrator	Advanced User	Generic User
Auto-Lock	YES	YES	NO
Lock	YES	YES	NO
Design	YES	NO	NO
Save	YES	NO	NO
Save As	YES	NO	NO
New	YES	NO	NO
Load	YES	YES	NO
Exit	YES	YES	NO

As indicated, the Administrator has the highest rank in the privilege hierarchy, followed by the Advanced User and generic users. All actions that may involve structural changes in a project are enabled in DESIGN mode only, accessible to an Administrator only (add, delete or rename devices, drag devices "online" in a project, save the project, open a new project, save "presets", create carousel or event lists, add or edit remote controls, etc.). All these operations are disabled in the different menus and controls when EclerNet Manager is in DEPLOY mode (everyday use mode) (see section **1.5. The toolbar**), the only mode all other users (advanced and generic) have access to.

- **Project Settings:** opens the project general settings window (also accessible by clicking on the Settings button in the toolbar).

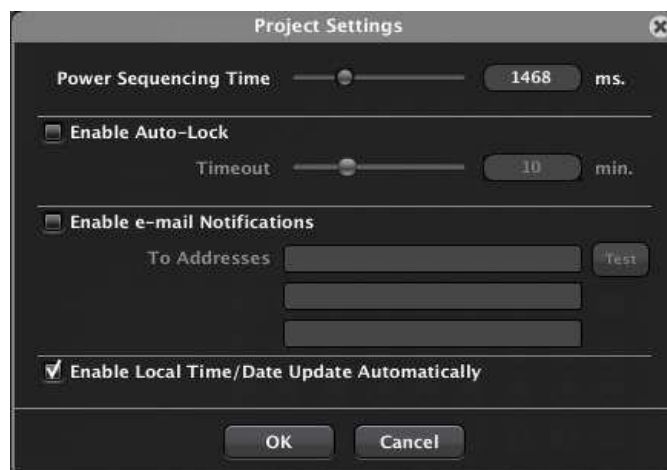

- **Power Sequencing Time (0 to 5000 milliseconds):** sets the power sequence time delay between a device and following devices involved in the Project.
- **Enable Auto-Lock and Timeout (1 to 30 minutes):** when you have assigned a password to anyone of the high-level users (Administrator and/or Advanced User), you may enter the protect mode of the project, either by pressing the Lock toolbar button, or once "auto-lock" (automatic activation of the protect mode) time out has passed without user activity on the Project when the option *Enable Auto-Lock* is checked. To re-access the DEPLOY or DESIGN mode, you must enter the password respectively assigned to the Administrator or Advanced User.
- **Enable e-mail Notifications:** enables/disables sending emails from the specified address (*From Address*) and to the three possible specified destinations (*To Addresses*) in the dialog box. Includes a "Test" button to test this function operation (when pressed, a test e-mail is sent).
- **Enable Local Time/Date Update Automatically:** allows the unit internal clock to automatically sync with Windows time changes, an especially useful function for daylight saving time.

Notes: (about e-mail sending)

- The e-mails sent include the project name in their subject field.
- To be able to send these e-mails, SMTP settings for the PC have to be done in the Edit / Preferences menu.
- There is a notice in the following cases:
 - Alarms
 - System Fault: for example, hardware failure (fuse, power supply...) of NPA series amplifiers.
 - Coded errors (hardware, firmware, DSP...)
 - RTC (Real Time Clock) reset
 - When a device is disconnected from Ethernet.
 - When you load a Project if some device is missing.
 - For an event designed for this purpose (available in future versions).

- **Preferences:** opens general preferences window for the application.

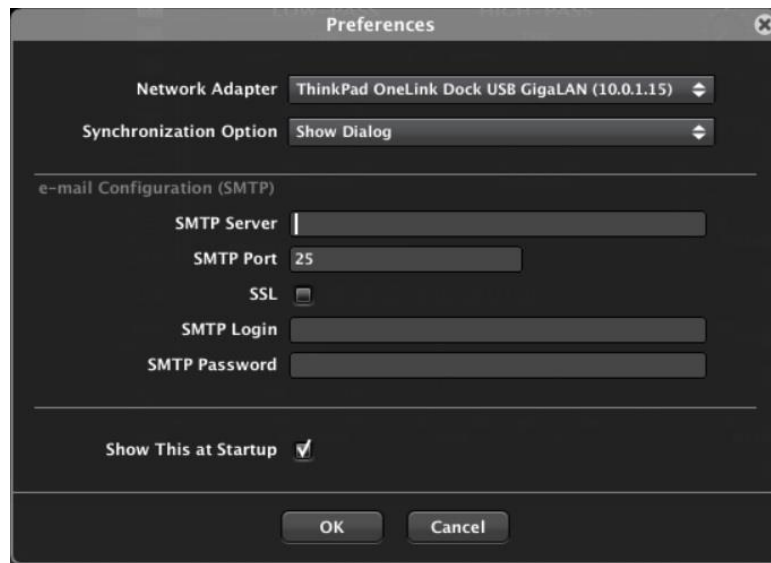

- **Network Adapter:** allows to select the network card interface that EclerNet Manager will use to discover and get online with the EclerNet hardware devices. It's especially helpful when using a computer with more than one network interface card (Wireless, RJ45, etc.).

It's a must to select an option to be able to get online with hardware devices in a network.

- **Synchronization Option:** defines how a hardware device and its virtual counterpart in the application will be synchronized when entering the *online* mode. The options are:
 - **Get State from Physical Device:** The Project is updated with data from hardware devices at connection time.
 - **Send State to Physical Device:** hardware devices are updated with current Project data at connection time.
 - **Show Dialog:** a dialog box appears each time to choose between option 1 and 2.
- **e-mail Configuration (SMTP):** configuration of the computer SMTP parameters to enable sending e-mail notification of alarms, errors and certain events registered in the application. Parameters: SMTP Server, SMTP Port, SMTP Login, SMTP Password. If the SSL box is checked, it enables the use of mail accounts with **Secure Sockets Layer** protocol (gmail, hotmail, yahoo, etc.).
- **Show This at Startup:** show this dialog box each time EclerNet Manager is executed

3.3. View Menu

- **Show Devices:** shows the devices view in the “Project Explorer”, “Groups from Device Container” and “Members from Device Group:” windows.
- **Show Channels:** shows the Channels view in the “Project Explorer”, “Groups from Channel Container” and “Members from Channel Group:” windows.
- **Show User Control Panels:** shows the view of the remote-control screens created for UCP (User Control Panels) or EclerNet Manager remote clients (see section **USER CONTROL PANELS (U.C.P.)**).
- **Enter Detail Mode (return) / Exit Detail Mode (esc):** toggles detailed view of the selected channel or device. The same function is performed by clicking on the Detail icon in the upper right corner of the application window ().
- **Enter Design Mode / Exit Design Mode:** enter / exit the application design mode. The same function is performed by clicking on the Design and Deploy toolbar buttons. All actions that may involve structural changes in a project are enabled in DESIGN mode only (primarily used by installers and / or high-level users), whereas DEPLOY mode can be considered as the system's daily management mode, not associated with structural changes. Operations considered as structural changes in a project are: add, delete or rename devices, drag devices "online" in a project, save the project, open a new project, save "presets", create carousel or event lists, add or edit remote controls, etc.).
- **Show Toolbar / Hide Toolbar:** shows/hides the toolbar under the menu bar.
- **Show Project Explorer / Hide Project Explorer:** shows/hides the Project browser window on the left side of the screen. The same function is performed by clicking on the Explorer toolbar button.

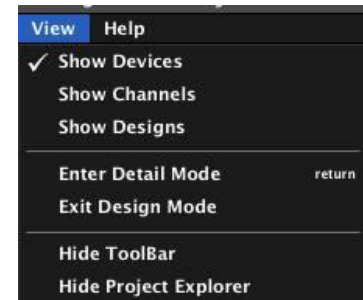

3.4. Help Menu

- **User Manual:** displays this user manual.
- **Visit the Ecler Web Site:** direct access to www.ecler.com.
- **Report Logs:** provides direct access to the folder containing the system log files on your hard disk.
- **About...:** displays the current version of EclerNet Manager application.

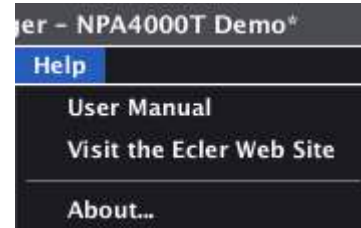

3.5. The toolbar

The toolbar contains the following buttons for a direct access to functions:



- **Explorer:** same function as *View -> Show Project Explorer / Hide Project Explorer* menu entry: shows/hides the Project browser window on the left side of the screen.
- **Design/Deploy:** same function as *View -> Enter Design Mode/Exit Design Mode* menu entry: to enter/exit the application design mode. All actions that may involve structural changes in a Project are enabled in DESIGN mode only (primarily used by installers and/or high-level users), whereas DEPLOY mode can be considered as the system's daily management mode, not associated with structural changes. Operations considered as structural changes in a Project are: add, delete or rename devices, drag devices "online" in a Project, save the Project, open a new Project, save "Presets", create carousel or event lists, add or edit remote controls, etc.).
- **Users:** same function as *Edit -> Project Users* menu entry: opens the configuration window for users and passwords (see section: [Edit Menu](#))
- **Settings:** same function as *Edit -> Project Settings* menu entry: opens the Project general settings window (see section: [Edit Menu](#))
- **Lock:** when you have assigned a password to anyone of the high-level users (Administrator and/or Advanced User), you may enter the protect mode of the project, either by pressing the Lock toolbar button, or once "auto-lock" (automatic activation of the protect mode) time out has passed without user activity on the Project. To re-access the DEPLOY or DESIGN mode, you must enter the password respectively assigned to the Administrator or Advanced User.
- **Panic:** activating it mutes all the output channels of the Project (absolute silence of the system.) Deactivating it restores MUTES ON or OFF configuration as it was before activation.
- **ECLER Logo:** direct access to www.ecler.com

4. APPLICATION WINDOWS

4.1. Available windows

The following windows are available in EclerNet Manager:

- **Project Explorer:** Project explorer for devices, channels and device or channel groups and control window design for EclerNet Manager remote clients. It can be enabled/disabled from the “View - > Show/Hide Project Explorer” menu or by the Explorer toolbar icon
- **Project Explorer Helper:** summary window, displayed at the bottom of the Project Explorer and showing:
 - A list of all devices in the Project (*Device List*)
 - A list of all channels in the Project (*Channel List*)
 - A list of devices detected on the network and currently not used in the Project (*Online and Unused Device List*)
 - Properties of the item selected in the Project Explorer (*Properties*)

Devices are identified in this window by their assigned name and IP address.

The *Project Explorer Helper* can be displayed and hidden by clicking on the triangle icon in the lower left corner of the *Project Explorer*.



4.2. Device Groups display windows:

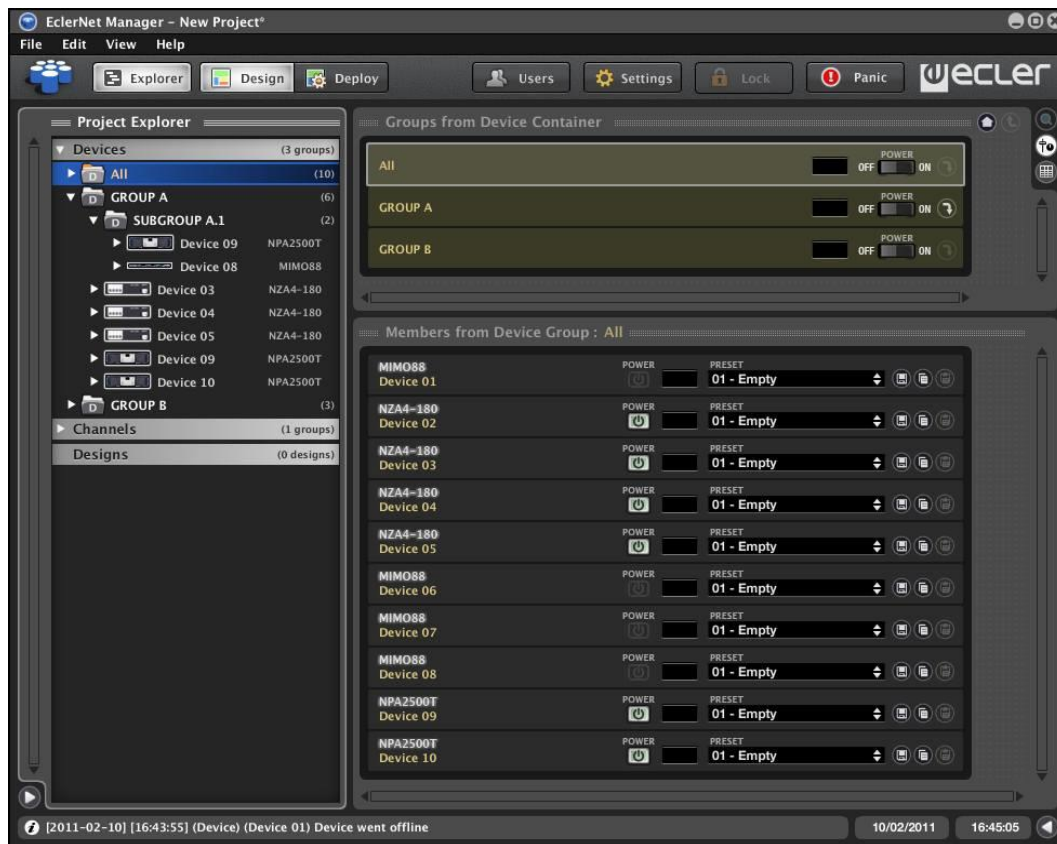

- **Groups from Device Container:** shows all existing device groups
- **Members from Device Group:** shows all existing devices and/or subgroups inside the group selected in the previous window

When selecting a particular group (double-click or icon ) , previous windows change to display the contents of this group, as in the example after selecting “SUBGROUP A.1”:

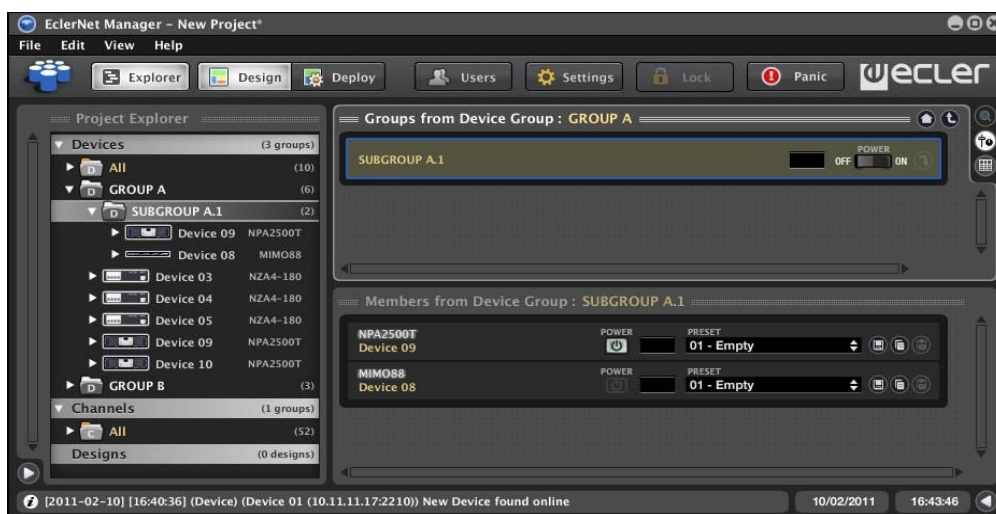



icons are used to go back in the group structure towards its root or the upper group container. Selecting a group in the *Project Explorer* also updates its detail windows.

You can create groups within groups (subgroups), as shown in the picture above. To include a device within a group, you must drag and drop it from its location onto the group. More information about this in chapter [EclerNet PROJECT](#).

4.3. Channel Groups display windows:



- **Groups from Channel Container:** shows all existing channel groups
- **Members from Channel Group:** shows all existing channels and/or subgroups within the group selected in the previous window

When selecting a particular group (double-click or  icon), previous windows change to display the contents of this group, as in the example after selecting “Group ch Floor”:

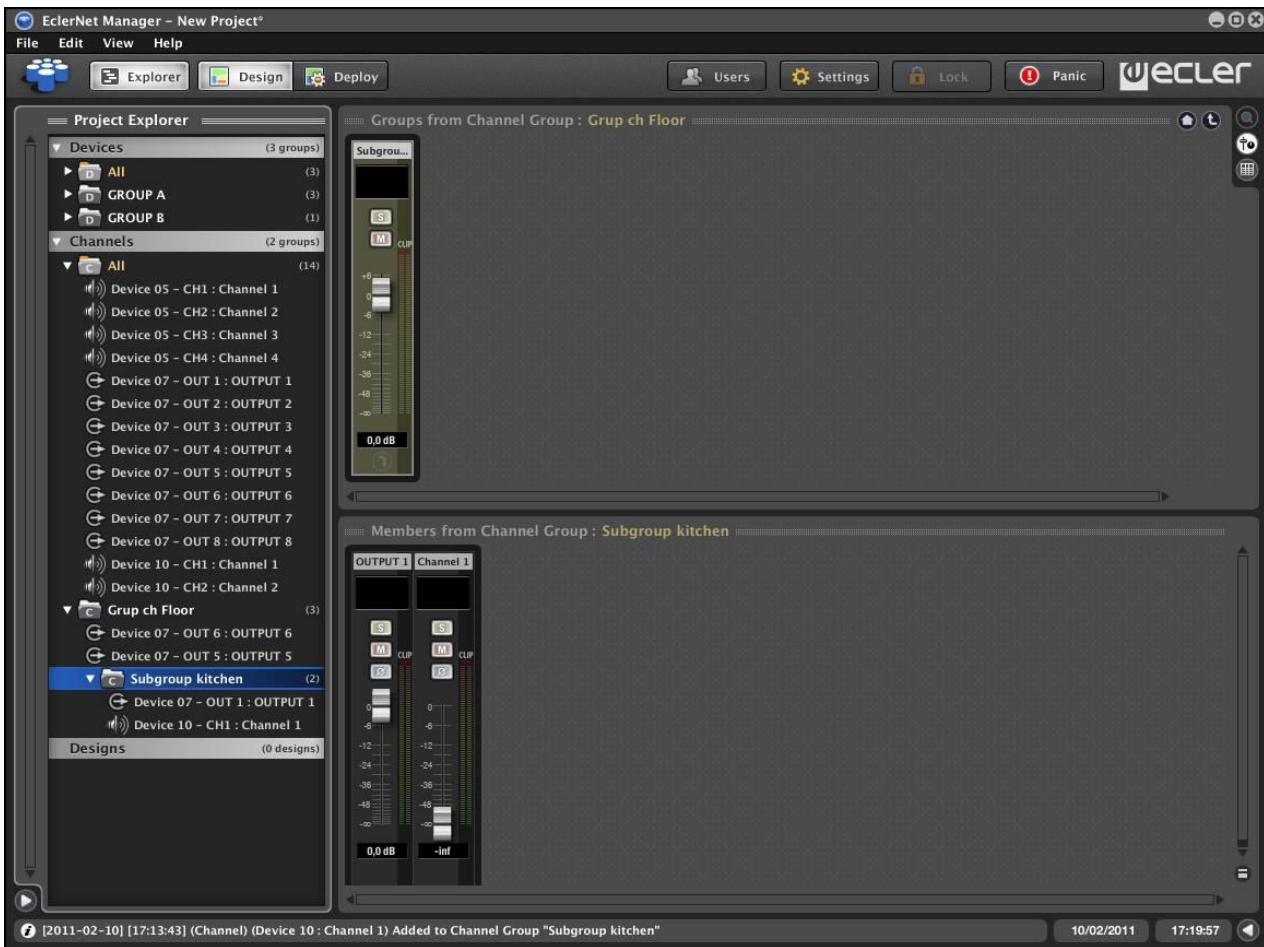

 icons are used to go back in the group structure towards its root or the upper group container. Selecting a group in the *Project Explorer* also updates its detail windows.

You can create groups within groups (subgroups), as shown in the picture above. To include a device within a group, you must drag and drop it from its location onto the group. See section: [EclerNet PROJECT](#).

Clicking on the “Show / Hide More Information” icon  in the lower right corner of the screen expands each channel viewing area with extra information, and two new icons appear above the previous one



With the two new icons, you can select units (volts or watts) and scale (RMS or peak) used to display the LED metering of the channel output signal (amplified) (function available with NPA series).



The 4 expanded views of a same channel in NPA series

- **Device:** device detailed display window, appearing only when Detail  mode is enabled. Shows all general controls for the device and/or one or more device channels (input selection, output configuration, network settings, DSP, monitoring, etc.)



Device window for NPA series device

There are several ways to turn on/off the Detail mode:

- Clicking on the Detail () icon in the upper right corner
- From the "View -> Enter/Exit Detail Mode" menu entry
- Double clicking on a device or channel in any of the Project windows
- Pressing Return or Esc after a channel or device selection in any of the Project windows

When the *Detail* mode is activated, the following icons appear in the lower right corner of the screen:

- Show / Hide Channel 1: shows/hides channel 1 controls for the selected device
- Show / Hide Channel 2: shows/hides channel 2 controls for the selected device
- ...
- Show / Hide Channel n: ditto the above for channel n, in NZA devices with 4 or 6 channels
- Show / Hide Graph: shows/hides a window graphically displaying the frequency-response curves resulting from crossovers and equalization applied to the corresponding channel by DSP processing (see section: [Detailed view](#)).



- **Report Log:** shows a record of major operations performed on the Project over time.

Date	Time	Type	Name	Description
2009-04-29	08:22:27	Device Group	DELAY REINFORCEMENT	Name changed
2009-04-29	08:22:43	Device Group	FULL SHOW	Name changed
2009-04-29	08:23:21	Device Group	MAIN PA	Name changed
2009-04-29	08:23:51	Device Group	REDUNDANT SYSTEM	Name changed
2009-04-29	08:24:11	Device Group	STAGE MONITORS	Name changed
2009-04-29	08:25:01	Device	Device 04	Added to Project
2009-04-29	08:26:29	Device	Device 05	Added to Project
2009-04-29	08:28:59	Device	Device 05	Added to Device Group "MAIN PA"
2009-04-29	08:29:09	Device	Device 04	Added to Device Group "MAIN PA"
2009-04-29	08:29:12	Device	Device 03	Added to Device Group "MAIN PA"

[2009-04-29] [08:33:00] (Device) (FRONT PA) Power ON

Shown/hidden by clicking on the triangle icon in the lower right corner of the EclerNet Manager screen.

The complete Report Log is stored as a text file on the hard disk. Report Logs option from the Help menu gives direct access to the folder containing log files or "report logs" generated since the system start-up.

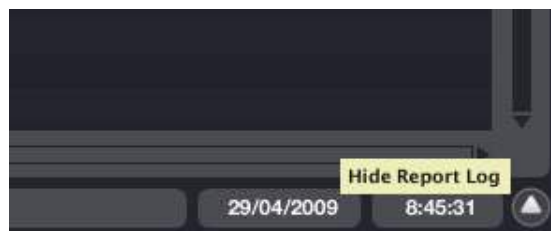

A separate file is created for each day of use (the file name includes the date). If you run and quit the application several times a day, this is reported in the file.

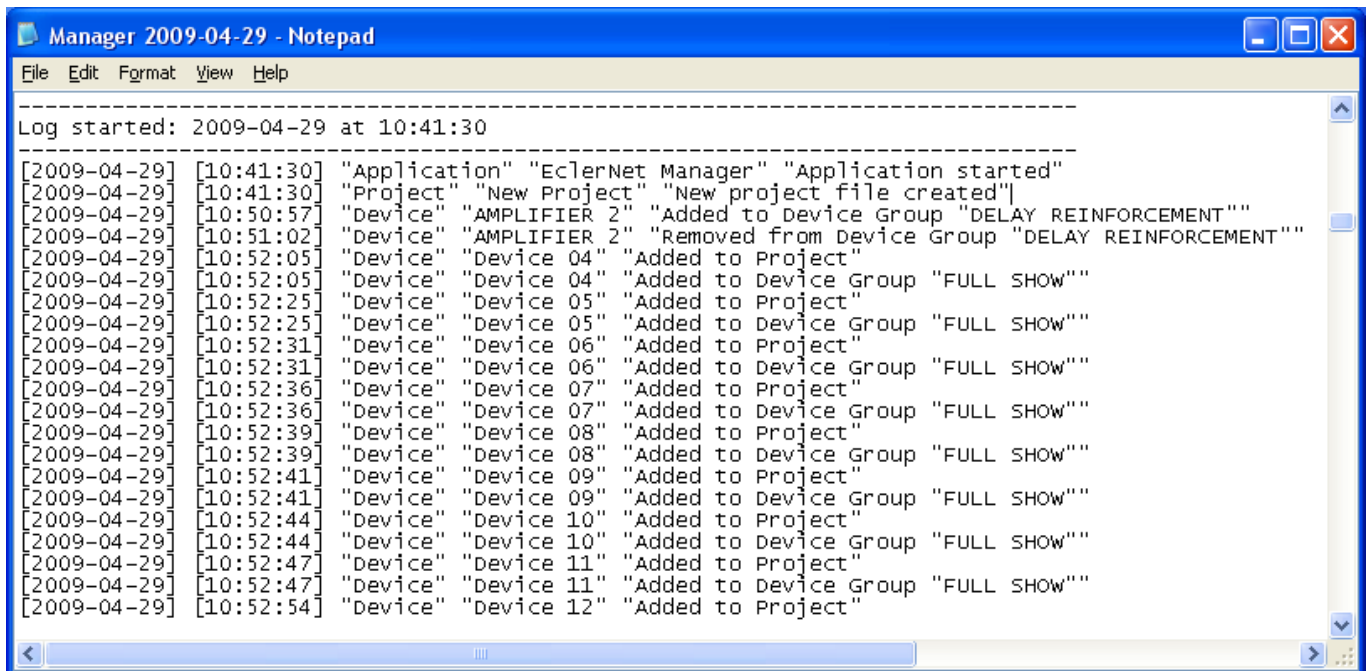

```
-----
Log started: 2009-04-29 at 10:41:30
-----
[2009-04-29] [10:41:30] "Application" "EclerNet Manager" "Application started"
[2009-04-29] [10:41:30] "Project" "New Project" "New project file created"
[2009-04-29] [10:50:57] "Device" "AMPLIFIER 2" "Added to Device Group "DELAY REINFORCEMENT""
[2009-04-29] [10:51:02] "Device" "AMPLIFIER 2" "Removed from Device Group "DELAY REINFORCEMENT""
[2009-04-29] [10:52:05] "Device" "Device 04" "Added to Project"
[2009-04-29] [10:52:05] "Device" "Device 04" "Added to Device Group "FULL SHOW""
[2009-04-29] [10:52:25] "Device" "Device 05" "Added to Project"
[2009-04-29] [10:52:25] "Device" "Device 05" "Added to Device Group "FULL SHOW""
[2009-04-29] [10:52:31] "Device" "Device 06" "Added to Project"
[2009-04-29] [10:52:31] "Device" "Device 06" "Added to Device Group "FULL SHOW""
[2009-04-29] [10:52:36] "Device" "Device 07" "Added to Project"
[2009-04-29] [10:52:36] "Device" "Device 07" "Added to Device Group "FULL SHOW""
[2009-04-29] [10:52:39] "Device" "Device 08" "Added to Project"
[2009-04-29] [10:52:39] "Device" "Device 08" "Added to Device Group "FULL SHOW""
[2009-04-29] [10:52:41] "Device" "Device 09" "Added to Project"
[2009-04-29] [10:52:41] "Device" "Device 09" "Added to Device Group "FULL SHOW""
[2009-04-29] [10:52:44] "Device" "Device 10" "Added to Project"
[2009-04-29] [10:52:44] "Device" "Device 10" "Added to Device Group "FULL SHOW""
[2009-04-29] [10:52:47] "Device" "Device 11" "Added to Project"
[2009-04-29] [10:52:47] "Device" "Device 11" "Added to Device Group "FULL SHOW""
[2009-04-29] [10:52:54] "Device" "device 12" "Added to Project"
```

4.4. Graphic/table display modes

Groups and channels windows can be viewed in graphic format (reflecting images shown in the previous paragraph) or as a table by clicking on the dedicated icons in the upper right part of the screen (these icons are visible only when *Detail* mode is off).



The screenshot shows two windows. The top window, titled 'Device Groups', contains a table with the following data:

Name	# Devices
All	9
DELAY REINFORCEMENT	2
FULL SHOW	9
MAIN PA	3
REDUNDANT SYSTEM	2
STAGE MONITORS	2

The bottom window, titled 'Devices from Group: FULL SHOW', contains a table with the following data:

Name	Model	MAC	IP Address	DELAY REINF...	FULL SHOW	MAIN PA	REDUNDANT...	STAGE MONI...
AMPLIFIER 2	NPA2500T		0.0.0.0	<input type="checkbox"/>	<input checked="" type="checkbox"/>	<input checked="" type="checkbox"/>	<input type="checkbox"/>	<input type="checkbox"/>
AMPLIFIER 3	NPA4000T		0.0.0.0	<input type="checkbox"/>	<input checked="" type="checkbox"/>	<input checked="" type="checkbox"/>	<input type="checkbox"/>	<input type="checkbox"/>
AMPLIFIER 4	NPA4000T		0.0.0.0	<input checked="" type="checkbox"/>	<input checked="" type="checkbox"/>	<input type="checkbox"/>	<input type="checkbox"/>	<input type="checkbox"/>
AMPLIFIER 5	NPA4000T		0.0.0.0	<input checked="" type="checkbox"/>	<input checked="" type="checkbox"/>	<input type="checkbox"/>	<input type="checkbox"/>	<input type="checkbox"/>
AMPLIFIER 6	NPA4000T		0.0.0.0	<input type="checkbox"/>	<input checked="" type="checkbox"/>	<input type="checkbox"/>	<input checked="" type="checkbox"/>	<input type="checkbox"/>
AMPLIFIER 7	NPA4000T		0.0.0.0	<input type="checkbox"/>	<input checked="" type="checkbox"/>	<input type="checkbox"/>	<input checked="" type="checkbox"/>	<input type="checkbox"/>
FRONT PA	NPA4000T		0.0.0.0	<input type="checkbox"/>	<input checked="" type="checkbox"/>	<input checked="" type="checkbox"/>	<input type="checkbox"/>	<input type="checkbox"/>
SM AMPLIFIER A	NPA4000T		0.0.0.0	<input type="checkbox"/>	<input checked="" type="checkbox"/>	<input type="checkbox"/>	<input type="checkbox"/>	<input checked="" type="checkbox"/>
SM AMPLIFIER B	NPA4000T		0.0.0.0	<input type="checkbox"/>	<input checked="" type="checkbox"/>	<input type="checkbox"/>	<input type="checkbox"/>	<input checked="" type="checkbox"/>

Table mode view

From the table mode view, you can add or remove devices or channels to/from existing groups by clicking on the corresponding check box.

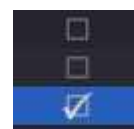

To select the columns displayed in the table place the cursor on the table title bar and right-click.

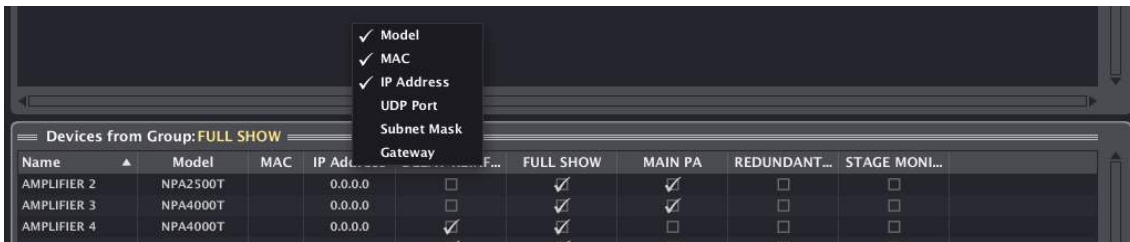

To reverse the alphabetical listing order, left-click on any table header.

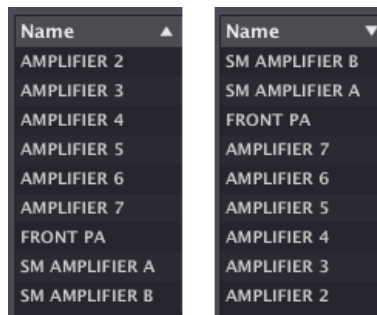

Ascending alphabetical order view/Descending alphabetical order view



Graphic mode view

5. CONTEXT MENU: RIGHT MOUSE BUTTON

Right-clicking on various Project elements will open a context menu with possible actions for each case.

5.1. Device context menu:

Available from any device view (*Project Explorer*, *Project Explorer Helper*, *Groups* window, etc.).

Options:

- **Rename (F2)**: renames device.
- **Edit Comments**: allows a brief comment about the device to be added/modified (configuration, role in the Project, etc.) These comments can be viewed from EclerNet Manager, placing the cursor over a device or channel (or from the hardware device itself with NPA Series: see NPA series hardware manual for more details.)
- **Delete**: totally removes the device from the Project. If the virtual device was associated with a hardware device on the network, this last one will appear in the “*Online and Unused Device List*” from *Project Explorer Helper* after its deletion.
- **Remove from Group**: removes the device from the group the context menu has been opened for.
- **Move Up (ctrl + ↑)**: moves up the selected device (changes the order within a group).
- **Move Down (ctrl + ↓)**: moves down the selected device (changes the order within a group).
- **Activate / Deactivate Device Finder**: activates/deactivates the blinking of the front panel light indicators (LCD display for NPA series, LEDs for NXA series, MIMO88, MIMO88SG and other devices) on targeted hardware, thus allowing easy identification on site. Simultaneously, the frame of the device shown in EclerNet Manager windows also blinks, making it possible to link a virtual device of the Project with its hardware equivalent, for example to configure its network settings or to check its identity before changing its settings.

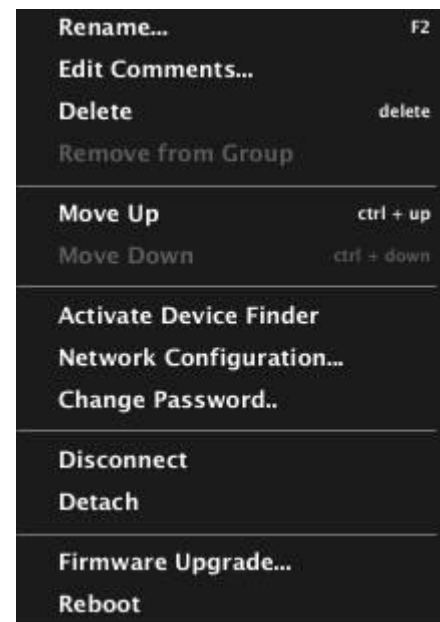

- **Network Configuration:** allows Ethernet parameters to be entered (and verified later) for the related device (IP address, subnet mask, gateway and UDP port). The MAC address is a read-only parameter, unique and assigned by the manufacturer to any Ethernet device.
- **Change Password:** allows the password to be assigned or changed in order to protect the device. When a device has this type of password (blank per default = OFF) assigned in a Project, the device cannot be re-programmed from other Projects unless you enter the correct password. Any change in the new Project will not be effective in the hardware device until password is entered, and it's indicated in the device status window by an exclamation mark on the connection indicator (🚨) and the flashing 🔒 icon
- **Connect / Disconnect:** connects (or disconnects) the device to the network, to make it available for remote control from EclerNet Manager.
- **Detach:** breaks the link between an EclerNet virtual device and its physical counterpart. The hardware device, if detected "online" on the network, becomes part of the "Online and Unused Device List" in the *Project Explorer Helper* window.
- **Firmware Upgrade:** opens a dialog box that allows you to load a device firmware file (with .bin extension) and to transfer it to the related device. The device must be "online" to perform this operation.
- **Reboot:** resets the device, following the usual boot sequence.



5.2. Channel context menu:

Available from any channel view (*Project Explorer*, *Project Explorer Helper*, *Groups* window, etc.).

Options:

- **Rename (F2):** allows the channel to be renamed.
- **Edit Comments:** allows a brief comment about the channel to be added/modified (configuration, role in the Project, etc.).
- **Remove from Group:** removes the channel from the group the context menu has been opened for.
- **Go to Device:** automatically selects the device the targeted channel belongs to, showing it in the currently active windows (graphic or table).
- **Move Up (ctrl + ↑):** moves up the selected channel (changes the order within a group).

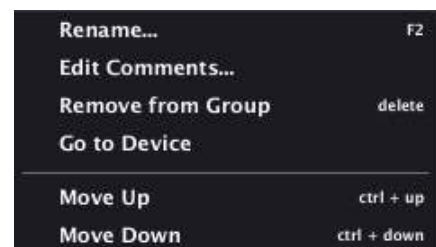

- **Move Down (ctrl + ↓)**: moves down the selected channel (changes the order within a group).

5.3. Device Group context menu:

Available from any device group view (*Project Explorer*, *Groups* window).

Options:

- **Rename (F2)**: allows the device group to be renamed.
- **Edit Comments**: allows a brief comment about the device group to be added/modified (configuration, role in the Project, etc.).
- **Delete**: totally removes the group from the Project.
- **Add Device**: adds a new device to the group and therefore to the Project.
- **Add Multiple Devices**: adds several new devices to the current Project.

Parameters:

- **Device Type**: selects in a list of compatible EclerNet device types the one to add.
- **Number**: number of devices to add.
- **Add Device Group**: opens a dialog box to create a new device group in the current Project.

Parameters:

- **Group Name**: allows the new device group to be named.

Note: you can create a group within a group (see section: [EclerNet PROJECT](#))

- **Empty**: removes all devices from the group, leaving it empty.
- **Move Up (ctrl + ↑)**: moves up the selected group (changes the order).
- **Move Down (ctrl + ↓)**: moves down the selected group (changes the order).
- **Connect All**: connects all group devices to the network, so they become available for remote control from EclerNet Manager.
- **Activate Device Finder**: enables the *Device Finder* for all online devices within the group.
- **Deactivate Device Finder**: disables the *Device Finder* for all online devices within the group.

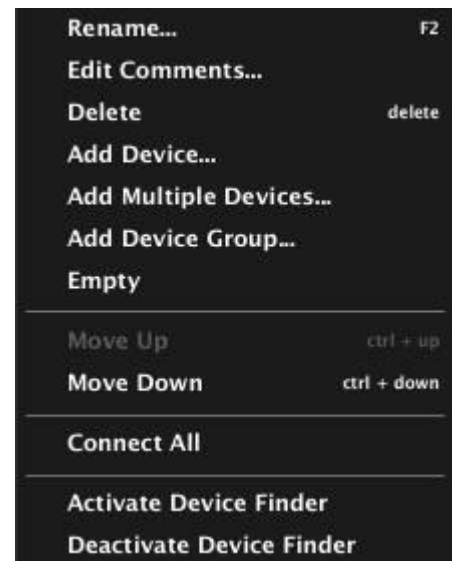

5.4. Channel Group context menu:

Available from any channel group view (*Project Explorer*, *Groups* window).

Options:

- **Rename (F2):** allows the channel group to be renamed.
- **Edit Comments:** allows a brief comment about the channel group to be added/modified (configuration, role in the Project, etc.).
- **Delete:** totally removes the group from the Project.
- **Add Channel Group:** opens a dialog box to create a new channel group in the current Project.

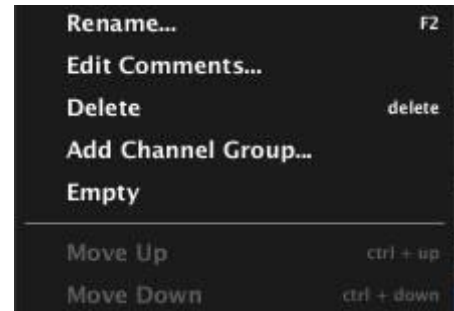

Parameters:

- **Group Name:** allows the new channel group to be named.

Note: you can create a group within a group (see section: [EclerNet PROJECT](#))

- **Empty:** removes all channels from the group, leaving it empty.
- **Move Up (ctrl + ↑):** moves up the selected group (changes the order).
- **Move Down (ctrl + ↓):** moves down the selected group (changes the order).

6. EclerNet PROJECT

A Project is a configuration and remote-control file for EclerNet device network. It contains a number of EclerNet virtual devices, structured according to a hierarchical arrangement of control groups for such devices and/or for their audio channels.

The purpose of a Project, once *online*, is to configure, remotely control and monitor a number of hardware devices connected to an Ethernet network. The network can include any combination of EclerNet compatible devices: NZA series amplifiers, NPA series amplifiers, MIMO88, MIMO88SG, MIMO1212SG, MIMO7272DN and MIMO4040CDN digital matrixes, DUO-NET PLAYER, etc.

The created file has the .enp extension and must be opened and operated from the EclerNet Manager application.

A Project can be created and edited offline, without being connected to the site Ethernet network, and later turned to online or real system management mode from a PC connected to the same network EclerNet compatible devices are connected to.

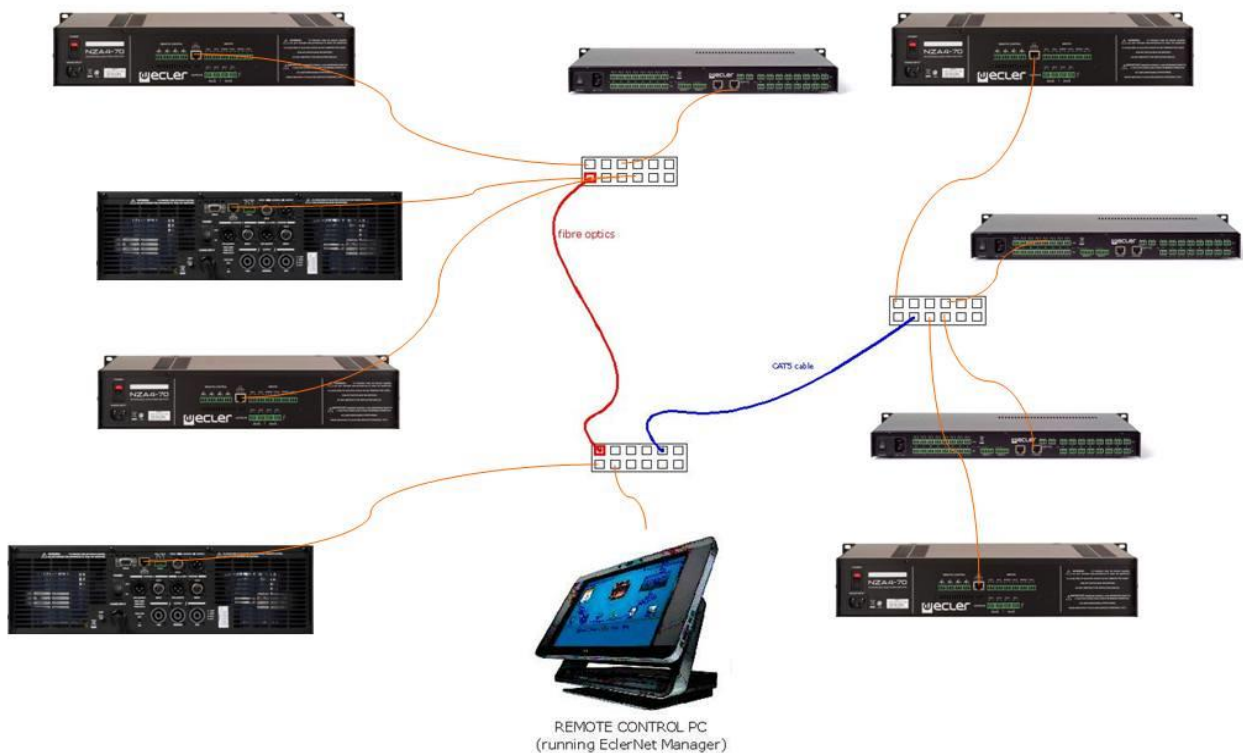

Example of EclerNet network including NZA, NPA and MIMO88 devices, the computer running EclerNet Manager and Ethernet network infrastructure that interconnects them.

6.1. Creating an EclerNet Project

The steps for setting up a Project from scratch are:

6.1.1. Opening of a new file

(File -> New menu entry or Ctrl + N keyboard shortcut). The default new Project window appears, looking like the following:

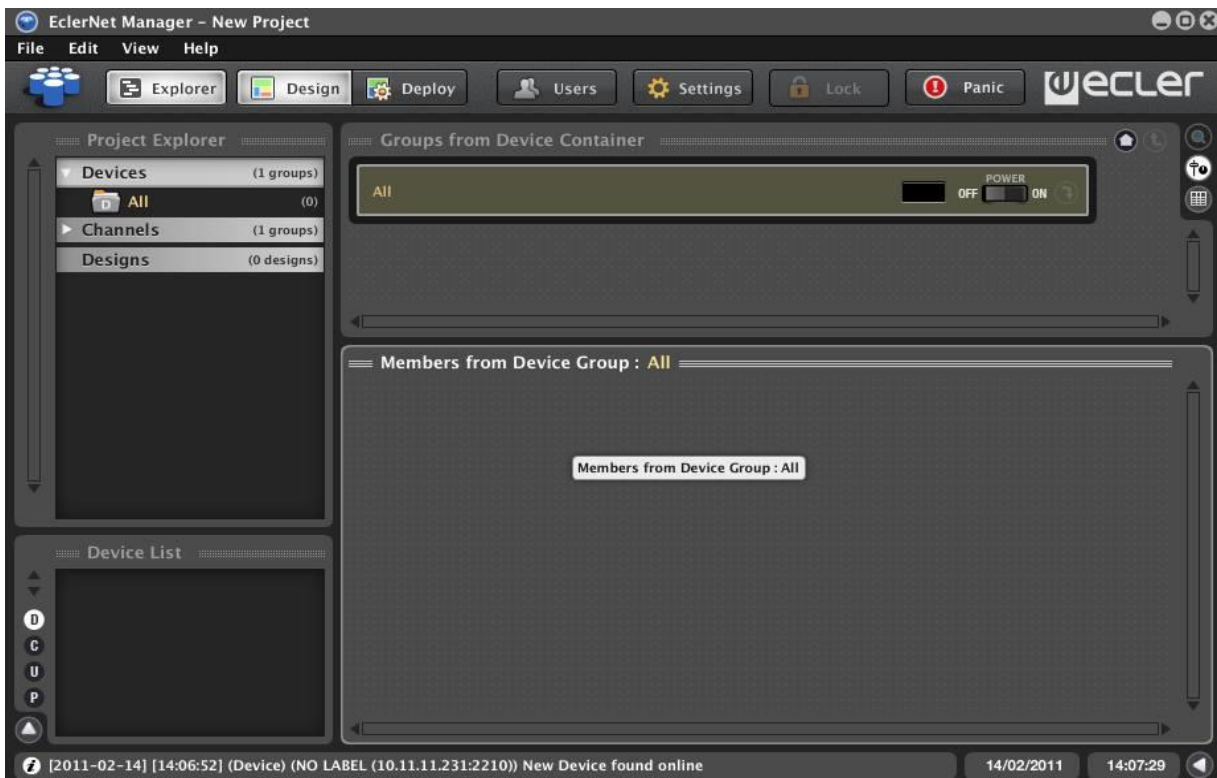

6.1.2. Insertion of new devices in the Project

(Edit -> Add Device menu entry). A dialog box opens to select the device type and assign it a custom name:

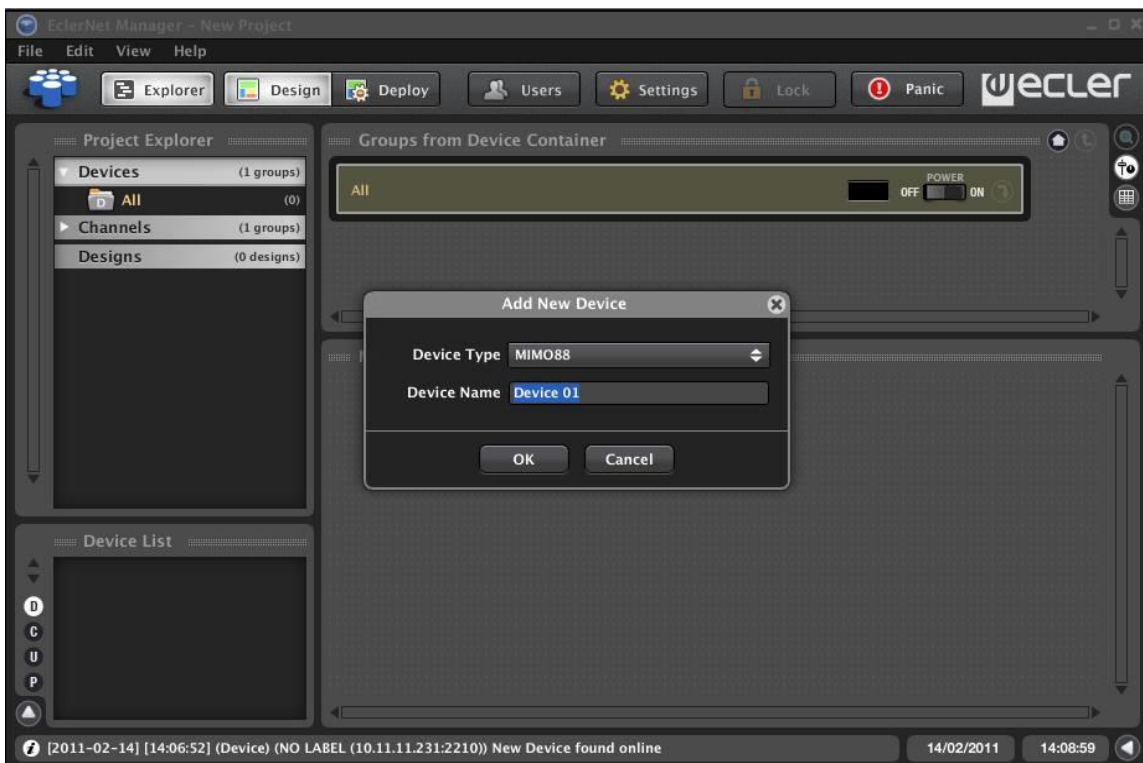

After clicking OK, the new device appears in the various Project windows:

1. Project Explorer
2. Project Explorer Helper
3. Groups from Device Container or Groups from Channel Container
4. Members from Device Group or Members from Channel Group

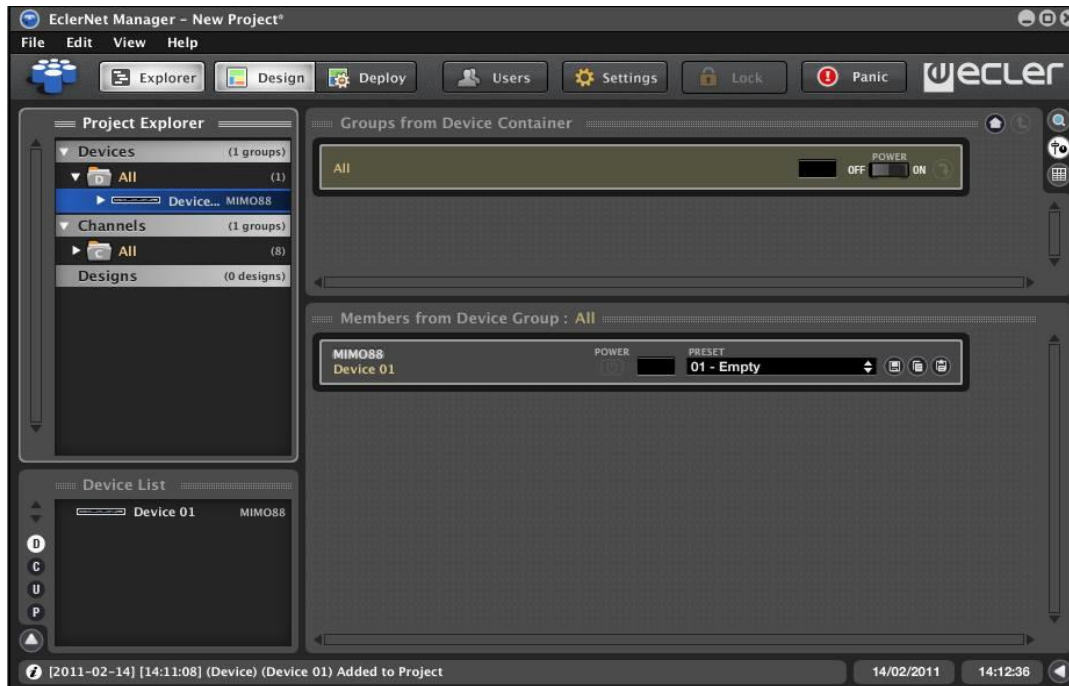

Added devices automatically appear in the “All” device and channel default groups, which respectively contain all the Project devices and channels. You can also add devices to the Project by right-clicking on a device group (*Add Device* option in the context menu).

6.1.3. Creating a device group.

There are two ways to create a device group:

1. Edit -> Add Device Group menu entry
2. Right-clicking on Devices in Project Explorer and Add Device Group option in the context menu



After their creation, the new groups appear in the corresponding Project windows.

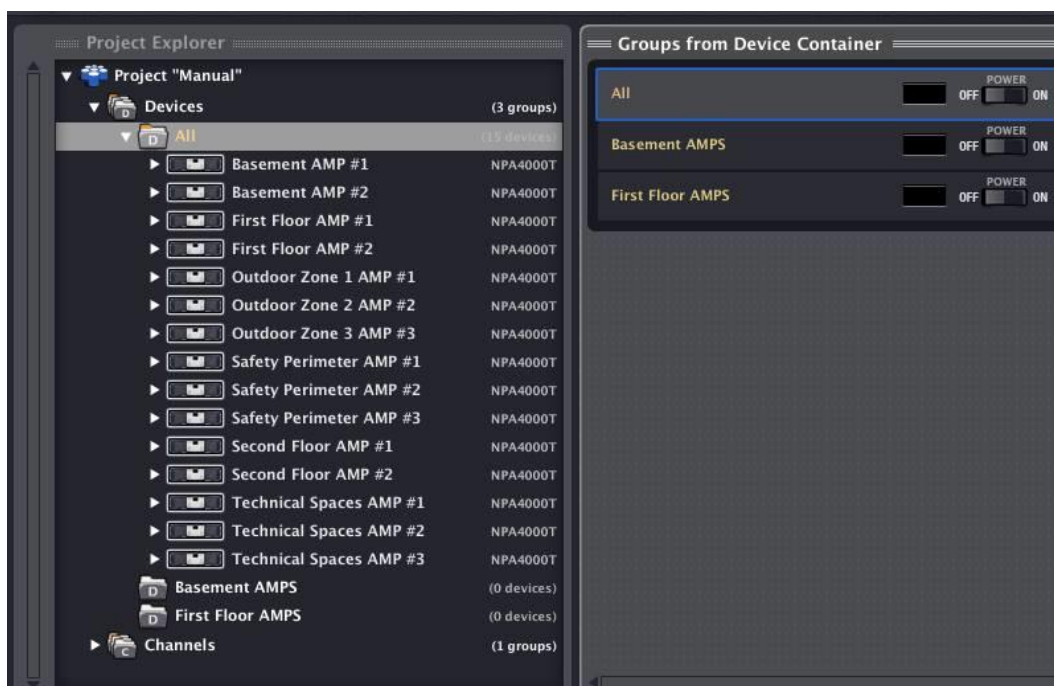

You can also create groups within groups:

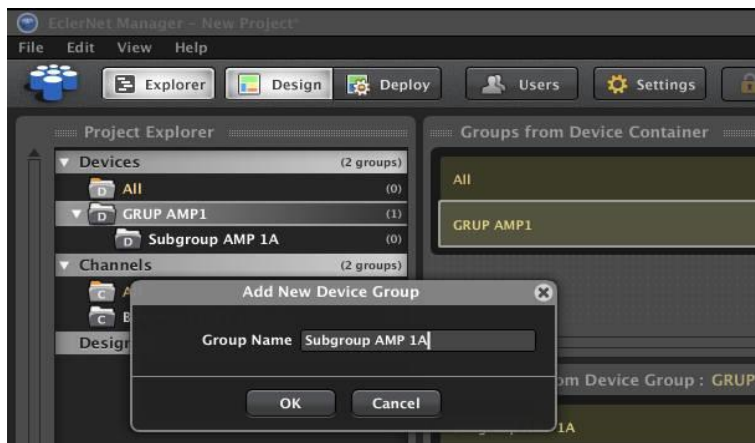

Assigning a device to a group of devices is as simple as dragging it from any window and dropping it in any window displaying the group. A green frame appears indicating that the destination of the drag and drop operation is validated and included in the Project.

The table mode view is another way to assign, where a device can be included or excluded in/from a device group by directly clicking on the column with the group name.

Example: different ways to assign the “Basement AMP #1” device to the “Basement AMPS” group:

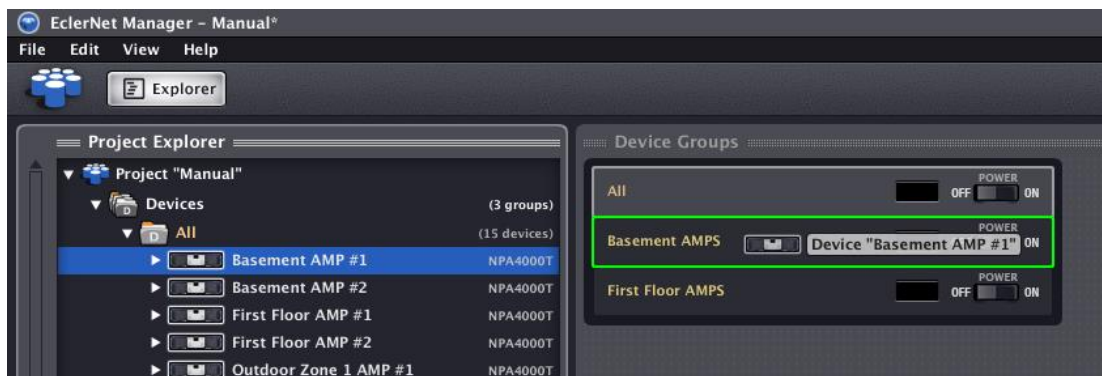

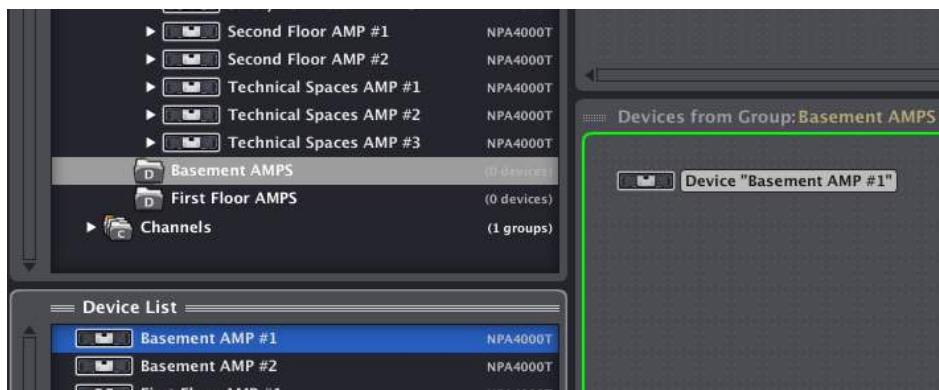
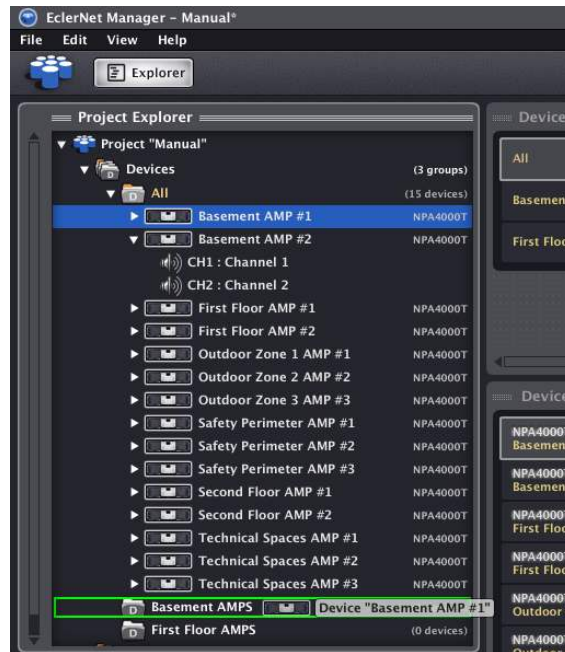

A device group provides both management and supervision (from the group control interface) of some controls concerning all devices in the same group (e.g. to sequentially turn on/off all group amplifiers by pressing the group *POWER* key).



6.1.4. Creating a channel group.

There are two ways to create a channel group:

1. Edit -> Add Channel Group menu entry
2. Right-clicking on Channels in Project Explorer and Add Channel Group option in the context menu

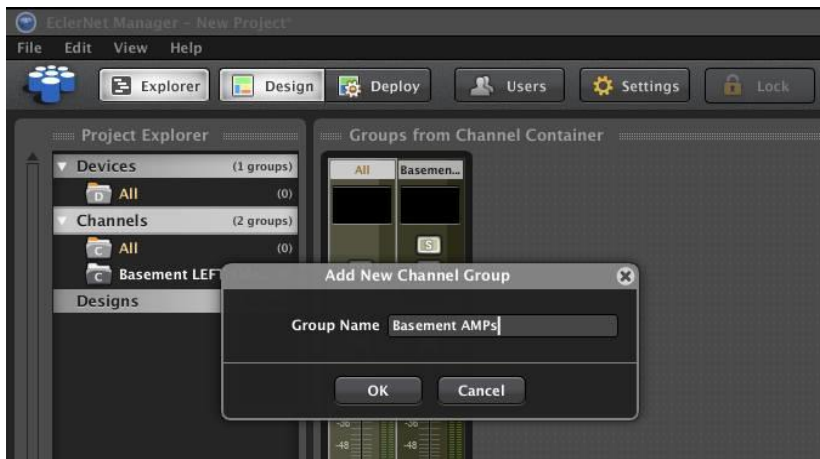

After creation, new groups appear in the corresponding Project windows.

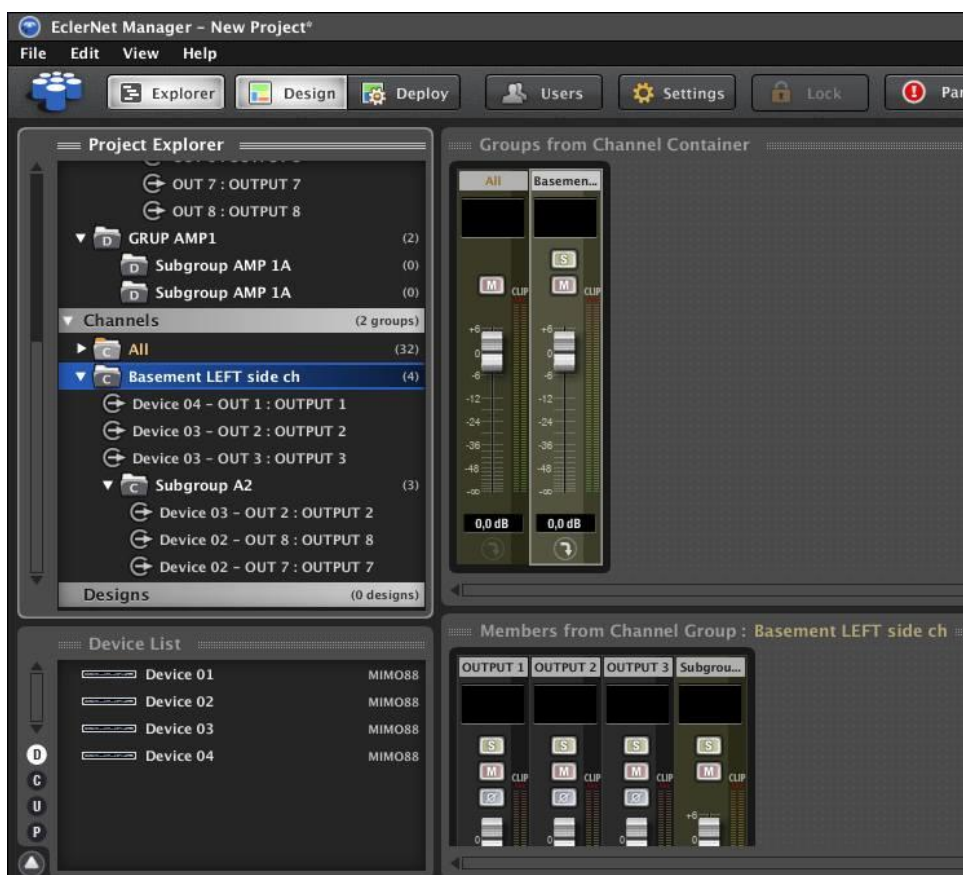

As with device groups you can also create channel groups within other channel groups.

Assigning channels to a channel group is done using the same “drag and drop” procedure already described for the device assignment to device groups.

Similarly, it is possible to achieve this in a very practical way with table mode.

Examples of different ways of assigning a channel to a channel group:

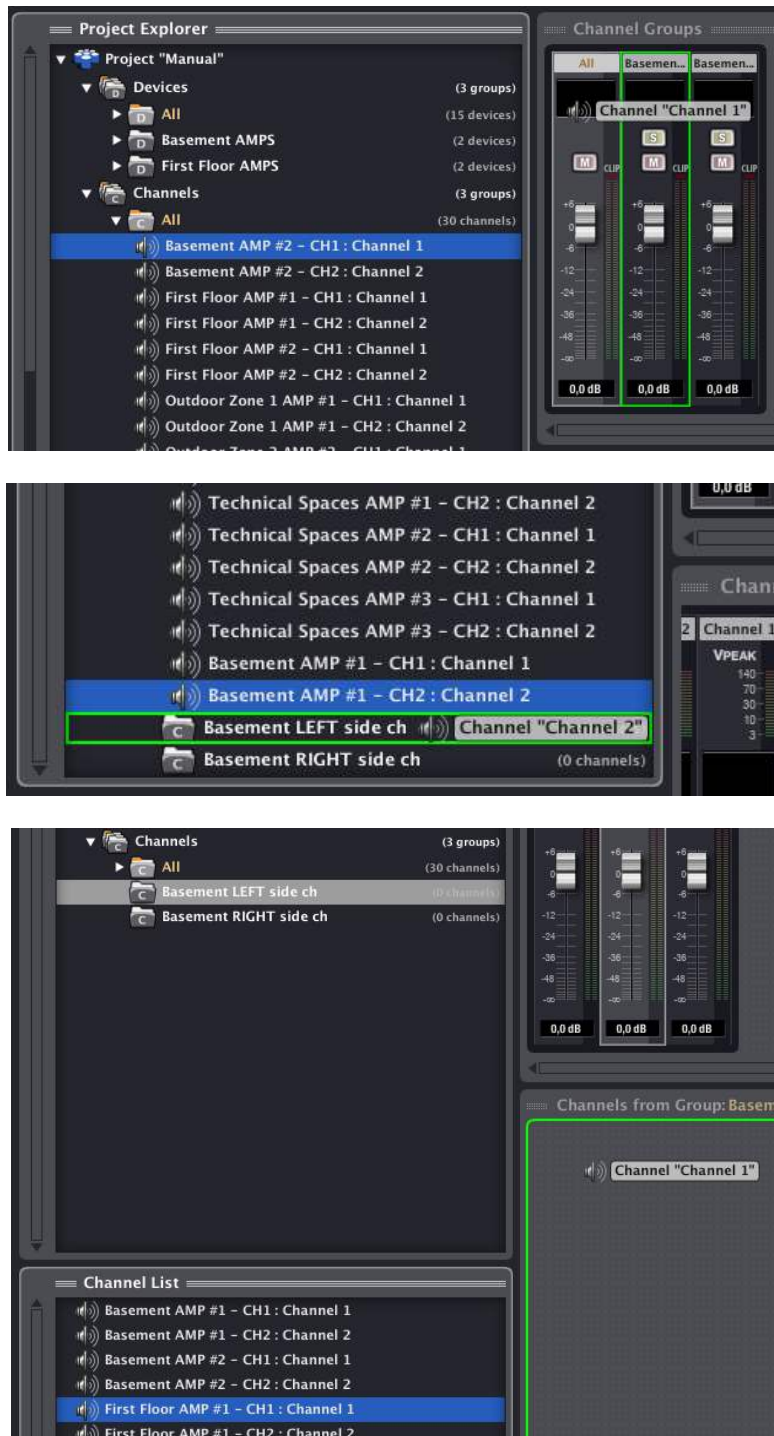

A channel group provides both management and supervision (from the group control interface) of some controls concerning all channels in the same group (e.g. to vary the volume or enable/disable MUTE or SOLO for all group channels by pressing the group M or S key).



6.1.5. Identification of networked devices.

NOTE: It's a must to select an option in the Edit -> Preferences -> **Network Adapter** menu to be able to discover and/or get online with hardware devices in a network.

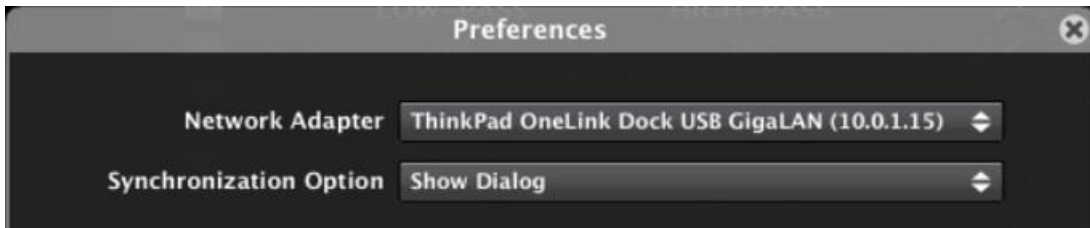

There are two methods to identify a Project device with its hardware counterpart on the network:

1. Configuration of device network parameters.

Using the Network Configuration option in the device context menu (right-click), you obtain network parameters that uniquely identify the hardware device configured with exactly the same parameters:

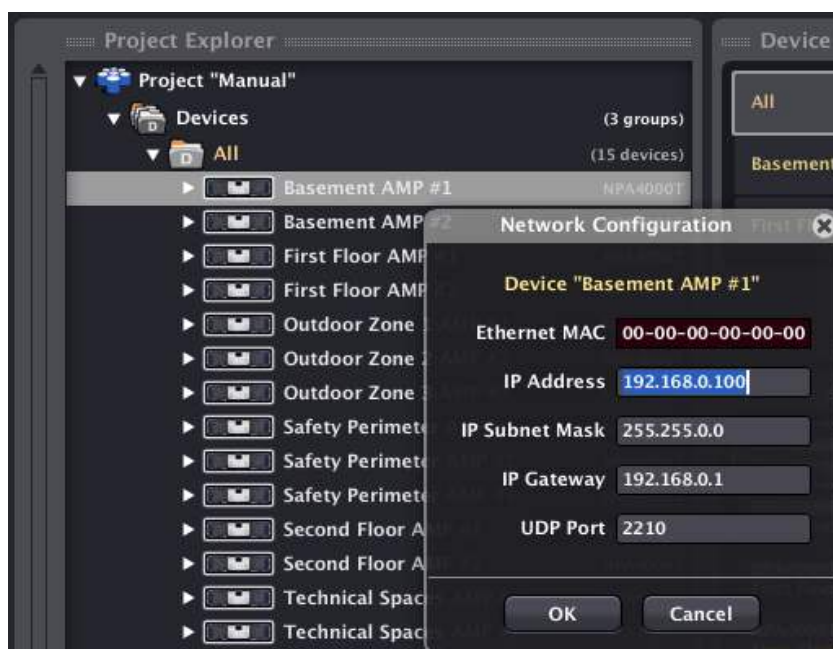

If there is no hardware device with the entered IP address in the network, selecting Connect from the context menu won't establish the connection between the device and EclerNet Manager (blinking red connection icon).

If there is such a device in the network, selecting **Connect** from the context menu opens the synchronization window which allows the Project virtual device current status to be sent to the hardware device, or the reverse: updating the Project virtual device status with the hardware device actual status. Once connection has been established (blinking green connection icon), the device is removed from the “*Online and Unused Device List*” in *Project Explorer Helper*.

Once synchronized, the device appears in EclerNet Manager with its green connection icon lit.

2. Direct identification with an online device.

The *Project Explorer Helper* window (*Online and Unused Device List*) displays all devices detected on the network and not assigned to Project virtual devices. You can use the “drag and drop” method to associate each one with its virtual counterpart in the Project:



After release, a window appears asking you to confirm the link between the hardware device and the Project virtual device. After confirmation, the device disappears from the “*Online and Unused Device List*” and a blinking red icon appears, indicating that connection is not established.

You can also drag an existing device from the Project Explorer Helper (Online and Unused Device List) and drop it directly on the device group “All” or any other device group of the Project to include it:



Or even add to the project all devices of the network by clicking on the "+" button located in the upper right corner of Project Explorer Helper:

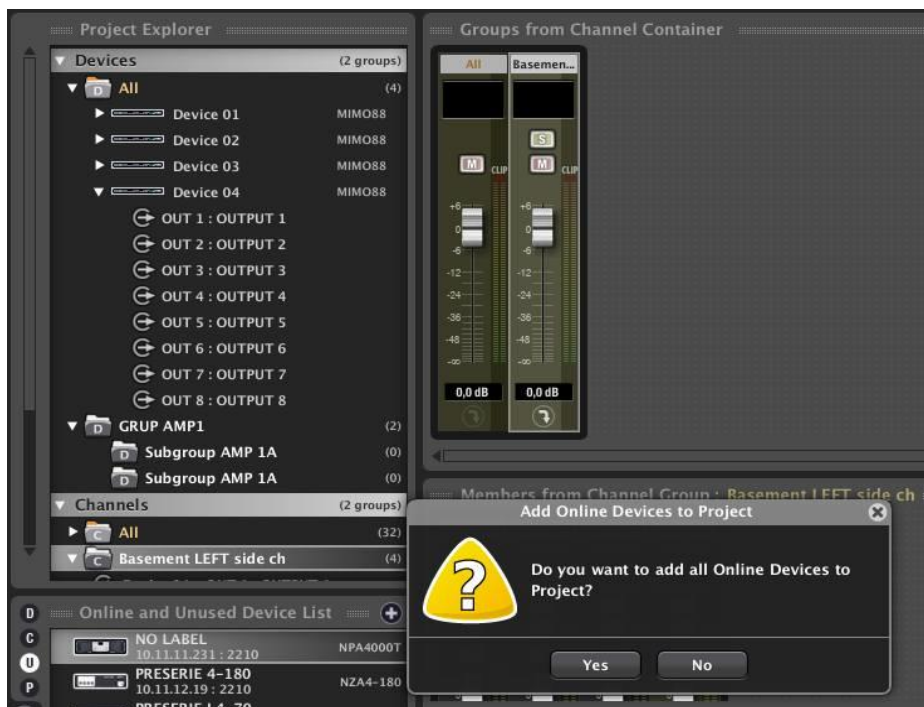

Note: device identification can be cancelled using the Detach option in the context menu.

IMPORTANT NOTE ABOUT ALLOCATION OF NETWORK PARAMETERS

EclerNet compatible devices (MIMO88, MIMO88SG, MIMO1212SG, MIMO4040DN, DUO-NET PLAYER, NXA, DUO-NET, NZA, NPA, etc.) **do not support dynamic allocation protocol for network addresses, or DHCP**, ie: they can't dynamically negotiate IP addresses and require manually configured and fixed IP addresses. It is highly recommended that both EclerNet devices (MIMO88, MIMO88SG, MIMO1212SG, MIMO4040DN, DUO-NET PLAYER, NZA, NPA, etc.) and the computer running EclerNet Manager are configured with static network addresses from the same range in order to have a full connectivity between all of them. An example of a small local network of this type may have the following network settings in its EclerNet devices:

DEVICE	IP ADDRESS	IP SUBNET MASK
MIMO88 (first floor)	10.5.5.10	255.255.255.0
MIMO88 (second floor)	10.5.5.11	255.255.255.0
MIMO88 (outdoor areas)	10.5.5.12	255.255.255.0
NZA6-180 (first floor)	10.5.5.20	255.255.255.0
NZA6-80 (second floor)	10.5.5.21	255.255.255.0
NZA4-700 (outdoor areas)	10.5.5.22	255.255.255.0
PC (running EclerNet Manager)	10.5.5.100	255.255.255.0

Up to 255 devices, each with a different IP address (in the range 10.5.5.1 – 10.5.5.255), could be part of this example network.

If you want to know your local network TCP / IP configuration, a simple method is to open the Windows command console (Start-> Run-> CMD) and to run **ipconfig /all** command. More information with the following link:

<http://www.microsoft.com/resources/documentation/windows/xp/all/proddocs/en-us/ipconfig.mspx?mfr=true>

Note: despite not supporting DHCP, EclerNet devices (and generally any device with static IP) can coexist with dynamic IP devices, as a DHCP server usually reserves a fraction of the addressing range for dynamic allocation and another fraction for static allocation.

6.1.6. Connecting the device.

Once a device has been identified (network parameters assigned), its connection status icon is lit in red.

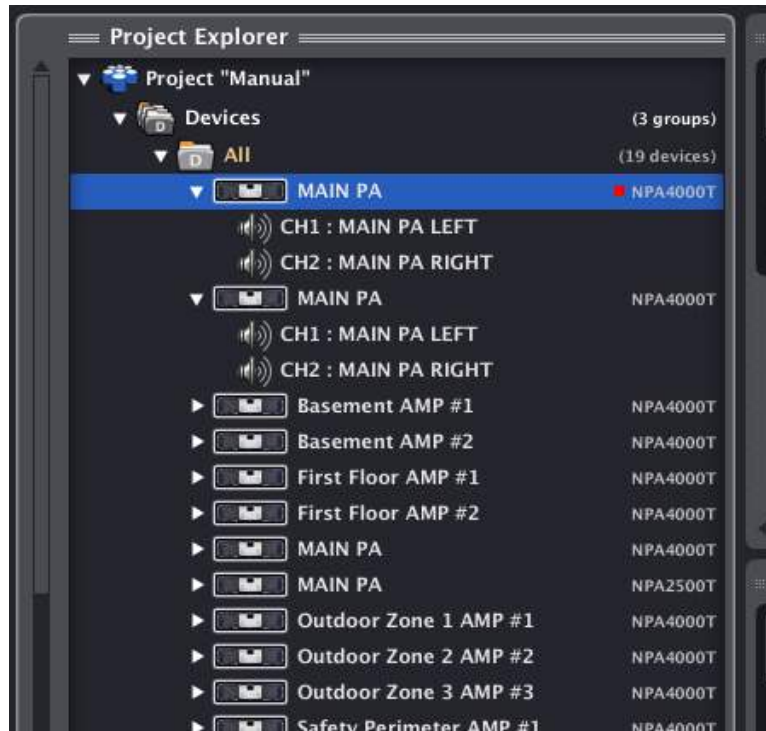

In the device context menu, a new option is available: Connect:

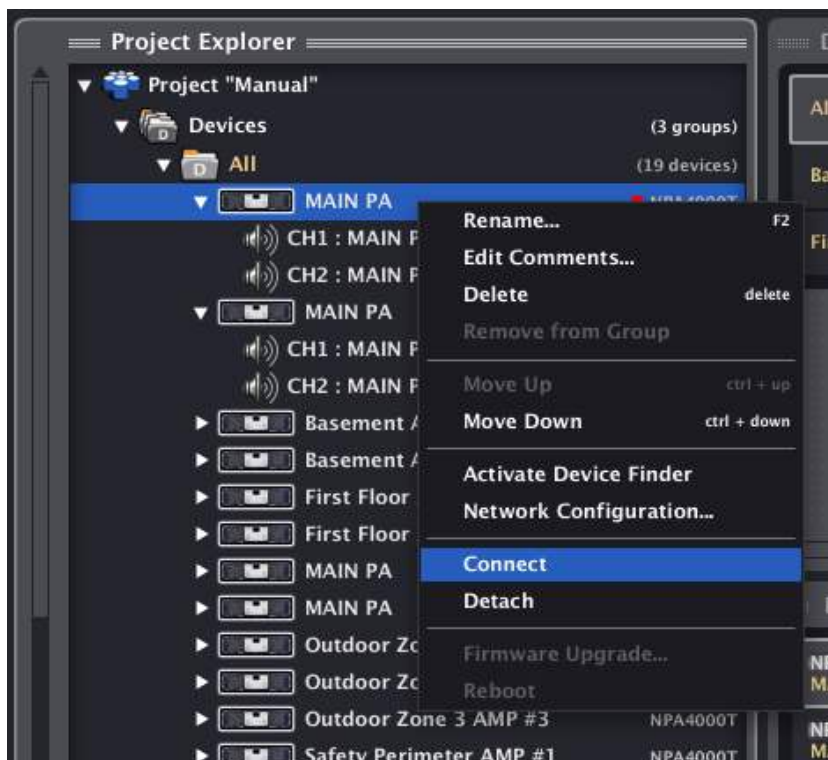

Selecting it opens the context menu window for the synchronization mode. From this window you must choose a synchronization mode for the device:

- send the current status of the Project virtual device to the hardware device
- or
- update the virtual device status in the Project with actual status of hardware device

Once connection has been established (blinking green connection icon), the device is removed from the “Online and Unused Device List” in *Project Explorer Helper*.

Once synchronized, the networked hardware device appears in EclerNet Manager with its green connection icon lit.

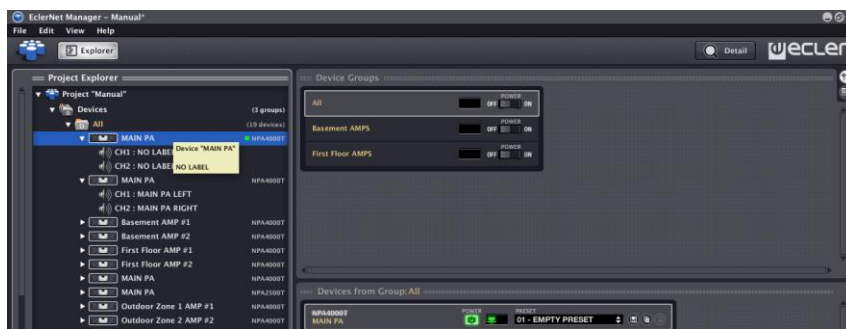

When a device is *online* and connected, all remote control and monitoring operations provided by EclerNet Manager can be performed, starting with the simplest, device powering up:

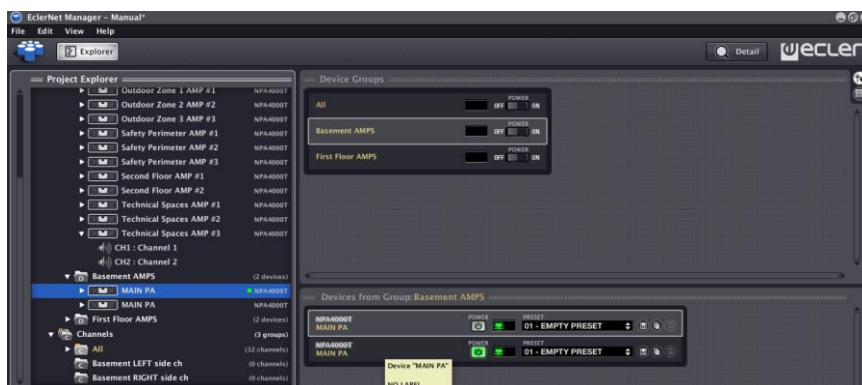

6.2. Customizing an EclerNet Project

It is advisable to perform some customization tasks on the Project in order to facilitate understanding and subsequent handling, such as:

- Rename devices. The name given to a device when adding it to the Project may neither be particularly handy nor descriptive. You can later rename the devices to meet those necessities.
- Rename device or channel groups. Ditto as above.
- Rename device channels. All channels are displayed by default with the name “Channel 1”, “Channel 2”, etc. It's really handy to choose a name referring to the device they belong to or representing their functional role in the installation:



- Add/edit comments for devices, channel or device groups. The context menu for these items (Edit Comments) allows associating a short text as a comment.



Placing the cursor over an item displays the associated comment window.

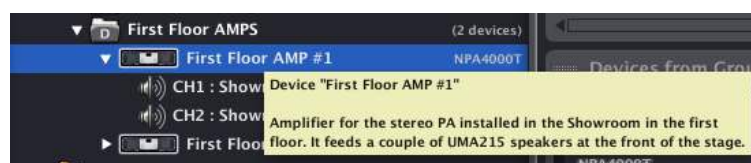

- Define Project options such as e-mail notifications, users, passwords, etc.:

See section: [Edit Menu: section “Project Users and Project Settings”](#)

Note: Passwords are blank by default for new Projects and are not requested to open them later, unless you edited them with the previous option.

- Save the Project.

The *File* -> *Save* or *File* -> *Save As* menu entries allow the Project to be saved on your local hard drive or another storage device, keeping the same name and location (*Save*) or with the ability to change both (*Save As*).





7. EclerNet PROJECT CONTROLS AND INDICATORS

7.1. Reduced view

The reduced view (*Detail* mode disabled) of a NPA, NZA, MIMO88SG, MIMO1212SG, MIMO4040DN, DUO-NET PLAYER, etc. device has the following appearance:



There are a number of user controls and icons or indicators to monitor the device:

	Device model and name
	Device remote Power switch (not available for MIMO88)
	Status monitoring and alarms window. See 5.4 Table of status monitoring and alarm icons
	Active Preset window: indicates the Preset (*) currently active in the device
	Presets management icons (**): <ul style="list-style-type: none"> • Save Device Preset (saves the current Preset) • Copy Device Preset (copies the current Preset) • Paste Device Preset (pastes the previously copied Preset to another Preset)

(*) A Preset is a snapshot of all the device settings at the time of saving: input selection, volume, EQ DSP, compressor settings, etc. For MIMO88, you can select which parts of the configuration will be stored in a given Preset:



Only those parts of a Preset will overwrite existing device settings when recalling this Preset, other MIMO88 parameters and settings won't be affected. For example, if only the Matrix is enabled when you save a Preset, the future recall of this Preset will overwrite the state of the M88 matrix only (crossing points between inputs and outputs, enabled or not, and their levels), without affecting any other setting (inputs, outputs, Pagers/Duckers, remote control enabling and link groups of the matrix, etc.).

Presets management is especially useful when a device has to behave differently at different times and/or for different applications without manually and individually editing its configuration.

(**) With Presets management, you can:

- Save a Preset with a specific name in the list of potential Presets of a device.
- Copy a Preset to a temporary memory
- Paste to a destination Preset the contents of another Preset previously copied in the temporary memory, in the same or another compatible device. This is especially useful when trying to clone Presets from one device to another or when you want to create a Preset by modifying an already existing one.
- When performing the pasting operation, all the content is pasted except the Preset name to be defined at the time of saving.
- Save a Preset on hard disk (right-click + Save Preset to file...)
- Load a Preset from hard disk (right-click + Load Preset from file...)

7.2. Detailed view

The detailed view (Detail mode enabled) of a NPA device has the following appearance:



The screenshot displays the detailed configuration interface for an NPA4000T device. The top section shows the device name 'NO LABEL' and 'NPA4000T' with a power indicator and 'PRESET' dropdown. The 'FIRMWARE' version is v1.01r8.

Channel 1 (CH1) Settings:

- GENERATOR:** SIGNAL: PINK NOISE; FREQUENCY: 20 Hz (range 600-20k Hz).
- CONFIG:** OUTPUT MODE: STEREO; VOLUME LINK: OFF; ANTICLIP MODE: SOFT; MAINS PROTECT: ---; NOW: 236,2 V; COUNT: ---; OPERATING TIME: 6242 h. 7 min.
- NETWORKING:** ETHERNET MAC: 00-1a-96-00-00-23; ADDRESSING MODE: MANUAL; IP ADDRESS: 10.11.11.231; UDP PORT: 2210; SUBNET MASK: 255.0.0.0; GATEWAY: 192.168.0.1.
- AES/EBU:** STATUS: ---; ATTENUATION: 0,0dB.
- CROSSOVER:** LOW-PASS and HIGH-PASS filters, both set to Bypass with a frequency of 20 Hz.
- PARAMETRIC EQ:** 8 bands, currently all bypassed.
- COMPRESSOR:** THRESHOLD: -18 dB; RATIO: 1:1; ATTACK: MIN; RELEASE: MAX.
- DELAY:** 0,00 ms.
- MONITOR:** PROTECT COUNT: 4; TEMPERATURE: 37,9 %; LOAD ERROR: ---.
- CONFIG:** GAIN: 38 dB; VPEAK LIMITER: OFF.

Channel 2 (CH2) Settings:

- CROSSOVER:** LOW-PASS and HIGH-PASS filters, both set to Bypass with a frequency of 20 Hz.
- COMPRESSOR:** THRESHOLD: -18 dB.
- MONITOR:** PROTECT COUNT: 4; TEMPERATURE: 36,9 %.

For NZA series amplifiers, the aspect is slightly different:



The screenshot displays the control interface for the NZA4-70 amplifier. At the top, it identifies the device as 'PRESERIE I 4-70' and shows the preset '01 - bingo' and firmware version 'v1.02r2'. The interface is divided into several sections:

- GENERATOR:** Includes a 'PINK NOISE' signal selector and a frequency knob ranging from 20 to 20k Hz.
- CONFIG:** Shows settings for 'ANTICLIP MODE' (SOFT), 'AUTO STANDBY' (ON), and 'OPERATING TIME' (6441 h, 57 m...).
- NETWORKING:** Lists network parameters: 'ETHERNET MAC' (00-1a-96-00-00-50), 'ADDRESSING MODE' (MANUAL), 'IP ADDRESS' (10.11.12.17), 'UDP PORT' (2210), 'SUBNET MASK' (255.0.0.0), and 'GATEWAY' (192.168.0.1).
- CH1 (Channel 1):**
 - CROSSOVER:** Features 'LOW-PASS' and 'HIGH-PASS' filters, both currently set to 'Bypass'.
 - PARAMETRIC EQ:** Includes a frequency knob and controls for 'GAIN' and 'Q'.
 - COMPRESSOR:** Controls include 'THRESHOLD' (ranging from -36 to 0), 'RATIO' (1:1), and 'ATTACK/RELEASE' (MIN/MAX).
 - OUT LEVEL:** Shows 'ENABLED' status, 'LEVEL' (0,0 dB), and 'REMOTE' (A).
 - DELAY:** Set to 0,00 ms.
 - STATUS:** Includes a 'CLIP' indicator and a 'SELECT' menu set to 'GEN'.
- CH2 (Channel 2):** Similar to CH1, but with the 'OUT LEVEL' set to 0,0 dB.

In case of a MIMO88 digital matrix:



Note: Detailed views of different EclerNet devices are extensively documented in chapters 6 and 7 of this manual.

Additionally, and for all EclerNet devices, by clicking on the Show / Hide Graph icon  (bottom right corner of the screen), you can display the window with frequency response curves resulting from DSP processing for equalization and crossovers applied to the device channels (see DSP processing section).



Examples of graphical panel respectively for NZA amplifier and MIMO88 matrix

In the graphical window for NPA and NZA series, the numbered icons located in the lower right corner allow you to activate/deactivate the graphical display for the device channels identified by the colour code of their own icons (red: Channel 1, Blue: Channel 2, etc.).

In the case of MIMO88, you can select which input or output channels are displayed, what colour will appear in the chart (double-click on *Change Colour* icon), and even have a summary of the selected filter parameters (in the upper band of the window).

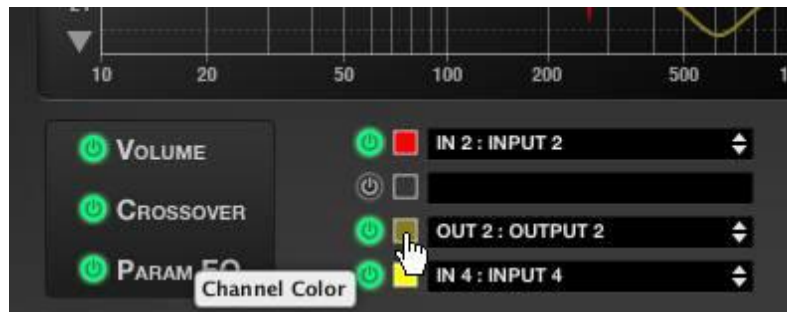

The graph displays the frequency response using a frequency X axis (logarithmic, in Hz) between 10 and 20,000 Hz, and a gain Y axis (in dB) between +12 dB and –30 dB, or between +12 dB and –72 dB (depending on the status of the Vertical Range button, located in the lower left corner of the graph).

7.2.1. Vertical range:

This control, located in the lower left corner of the graph, allows you to choose between two different ranges of values for the graph Y-axis (gain in dB).



When the button has a pointing down triangle shape, the gain range is between +12 dB and – 30 dB. When the button has a pointing up triangle shape, the gain range is between +12 dB and – 72 dB.

The curve can be displayed as solid (filled) or as contour line only (outlined), depending on the **SOLID** button status.

Only one of the available channels is selected as active. The active channel is displayed with greater intensity than the rest, which appears semi-transparent. Channel selection is done by clicking with the mouse on the desired device channel's panel.

If the MUTE function of any channel is activated, this channel graph is represented as a horizontal line at the bottom of the chart.

Only one of the filters in the active channel is considered as the active filter in the graph. This filter individual response is represented with a white line. The filters selection is done by clicking on the panel where the targeted filter controls are displayed. For parametric equalization, individual selection of each of the filters is done through numerical identifiers in the control panel (from 1 to 8).



The active channel filters whose type is not *Bypass* are represented in the graph as circular markers. The low-pass crossover is labelled "L", the high pass crossover is labelled "H", and parametric filters have a numerical identifier, from 1 to 8.

The graph allows interactive editing of the filter's parameters using their markers. To do this, you just have to point the mouse on the filter marker you want to edit, to click on it and drag it on the surface of the chart while holding the button pressed.

The active filter marker is displayed with greater intensity than the others (which appear semi-transparent) and shows an animation with arrows indicating the available moving directions; crossovers, for example, can only be moved horizontally (*Frequency* parameter), while *High-Shelf*, *Low Shelf* filters and *Parametric EQ* can move horizontally (*Frequency* parameter) and vertically (*Gain* parameter).

For filters with a Q parameter (*Parametric EQ*, *All-Pass order 2*), Q value may also be edited through graphic markers using the mouse wheel.

7.2.2. Filled curves (Solid):

This other control, located in the lower right corner of the graph, allows you to select the option to fill the chart or not.  

A black **SOLID** word over a white rectangle means the graphic curve is filled. A white **SOLID** word over a black rectangle means the graphic curve is only outlined.

7.3. Types of control

The detailed view of an EclerNet device contains various types of user controls, which allow you to adjust parameters for DSP processing. The main types of controls are:



7.3.1. Adjustment potentiometers

To rotate a potentiometer, place the mouse cursor over it, left click, hold the mouse button and drag up (or right) to rotate clockwise or down (or left) to rotate counter clockwise.



You can also change a potentiometer value by hovering over with the mouse, pressing the left mouse button and turning the mouse wheel.

Double-clicking a potentiometer will reset it to the default position (depending on the parameter).

7.3.2. Channel Fader

The fader is a graphic sliding control. To move the fader, point the mouse cursor on it, left click, hold the mouse button and drag up or down.

You can also change a fader value by hovering over with the mouse, pressing the left mouse button and turning the mouse wheel.

Double-clicking it will restore the default position (0 dB).



7.3.3. Buttons

All buttons operate the same way: to activate a button, you should point the mouse cursor on it, press and release the mouse left button.



7.3.4. Selectors

Some parameters must be chosen with selectors from a list of available values. These controls are identified by their double arrow pointing up and down on their right side.

To select a new value in the list, click the control with the mouse and a list of all available values will appear. Select the new value with the mouse by left click on it. The list will close and the new element will appear selected in the control.



7.3.5. Numerical values

Some of the above controls have an associated display showing the numerical value. These displays can also be used to edit the parameter value.

To edit a numerical value, you just have to place the mouse cursor over it and left click. Automatically, the control enters edit mode allowing typing the desired value (only numbers without units).









Pressing the ENTER key will update the associated control value. Pressing the ESC key will cancel the editing and keep the previous value.









Double-clicking some controls will reset them to their default position.







7.4. Table of status monitoring and alarm icons

Icons indicating the status of any system function or any alarm triggering appear in different windows:

 	<p>Device disconnected.</p> <ul style="list-style-type: none"> • Steady red: the device has been manually disconnected (with Disconnect option). • Blinking red: EclerNet Manager tried to connect to the device, but this one is not available.
	<p>Device connected. Blinking green.</p> <p>The device is correctly connected to EclerNet Manager.</p>
	<p>Device connected and synching.</p> <p>The device is establishing the connection to EclerNet Manager.</p>
	<p>Device connected with warning.</p> <p>The device is connected, but there is a problem.</p> <p>If the icon is displayed in a device status area, then another icon indicates the kind of problem (invalid EclerNet protocol version, unsynched, etc.).</p> <p>If the icon is displayed in a channel status area, it's indicating a problem with the device (it is recommended to consult the device status area for more information).</p>
	<p>Invalid EclerNet protocol version.</p> <p>The current version of EclerNet Manager does not allow its connection to networked devices (Version mismatch between software and firmware). Therefore, no connection can be established, but it is possible to upgrade the firmware from Project Explorer Helper.</p>
	<p>Invalid password.</p> <p>The password entered in the device is incorrect.</p>
	<p>Device unsynched. The two icons are alternatively displayed.</p> <p>Hardware content (state, presets ...) does not match the device content in EclerNet Manager.</p>

	<p>Device powered.</p> <p>The device is switched on (POWER ON).</p>
	<p>Channel protect alarm.</p> <p>The electronic protection alarm is activated for the channel. It lights up for a few seconds during the boot sequence and it's normal.</p>
	<p>Channel thermal alarm.</p> <p>The thermal protection alarm is activated for the channel.</p>
	<p>Channel load alarm.</p> <p>The impedance load protection alarm is activated for the channel.</p>
	<p>Device mains voltage alarm.</p> <p>The AC power voltage alarm is activated for the device.</p>
	<p>Device system error.</p> <p>Device error alarm (some component inside the device is malfunctioning)</p>
	<p>Device system fault.</p> <p>Device malfunction alarm (blown fuse, protection system permanently triggered, etc.).</p> <p>This alarm appears along with a fault window in the device LCD.</p>
	<p>Slave link fault.</p> <p>MASTER-SLAVE connection between two MIMO88s is not valid (physical link between the LINK BUS connector on the back panel of both MIMO88 units and crossover CAT5 cable).</p> <p>Possible Causes:</p> <p>Connection is lacking or is defective</p> <p>The rear panel switch of the SLAVE unit is not on SLAVE position</p>

	Invalid Slave version. Software - firmware version mismatch in the SLAVE unit of a pair of MIMO88s.
	Channels group set in SOLO mode
	Can Bus DC Power Fail (MIMO units)
	NXA units self-test has reported one or more channels having issues

Note: some of these icons are device dependent, being only available for some series and/or models.

8. COMPATIBLE DEVICES: amplifiers / digital audio managers



8.1. NPA and NZA amplifiers series



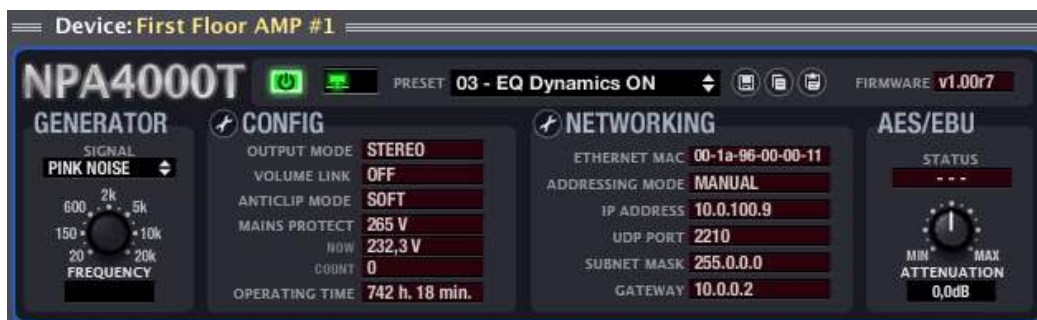

8.1.1. NPA and NZA series detailed view

8.1.1.1. NPA series detailed view

The top section of the detailed window provides the following items:

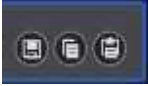

	Device model and name
	Device power switch
	Status monitoring and alarms window. See Table of status monitoring and alarm icons

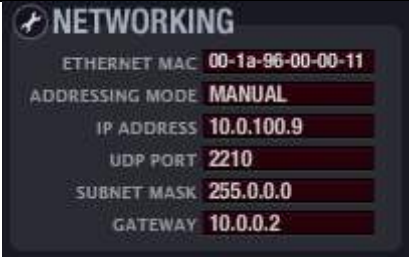
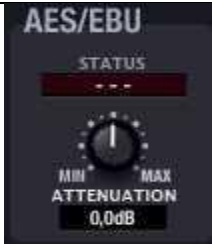
	<p>Active Preset window: indicates the Preset currently active in the device (See section: Reduced view)</p>
	<p>Presets management icons:</p> <ul style="list-style-type: none"> • Save Device Preset (saves the current Preset) • Copy Device Preset (copies the current Preset) • Paste Device Preset (pastes the previously copied Preset) <p>(See section: Reduced view)</p>
	<p>Unit's firmware version</p>
	<p>Internal signal generator offering pink noise, white noise, sine wave and polarity check, with frequency adjustable between 10 and 20,000 Hz</p>
	<p>Device configuration. See (1)</p>
	<p>Network parameters configuration. See (2)</p>
	<p>Digital AES/EBU input: a VALID message is displayed when a valid AES/EBU signal is input in the device.</p> <p>Provides a ± 12 dB trim adjustment</p>

(1) Device configuration.

Clicking on the configuration edit icon opens the parameter setting window:



For an NPA Series amplifier, adjustable parameters are:

- **Output Mode:** STEREO/BRIDGE/PARALLEL.
Selects the operating mode of the device amplified outputs: stereo, bridged or parallel (see the hardware NPA Series owner's manual).
- **Volume Link:** ON/OFF.
Determines if both channels' volume controls of an amplifier are linked (ON) or independent (OFF).
- **Anticlip Mode:** SOFT/MID/HARD.
The protection system against saturation can operate in SOFT, MID, or HARD mode.
- **Maximum Mains Voltage:** 200 to 280 V AC (version for 230 V AC nominal voltage.)
Determines the AC mains voltage threshold above which overvoltage occurs.
- **Enable Mains Voltage Alarm:** Determines whether threshold exceeding should trigger or not a system alarm.

The window hereunder shows the adjustments made, the real time reading of the voltage (*NOW*), the number of times it exceeded the threshold (*COUNT*) and the cumulative operating time of the device (*OPERATING TIME*):

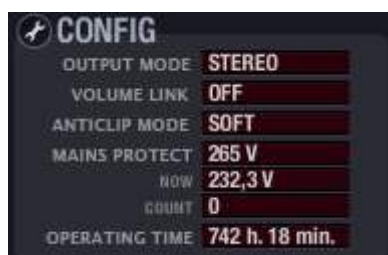

(2) Network parameters configuration.







Exactly the same window and same parameters than those available with Network Configuration in the device context menu:



See section [Creating an EclerNet Project](#) for more details.

The lower right section of the device channel window presents the following appearance for NPA Series:



	Counter for the number of times the device protection alarm has been triggered
	Heat sink internal temperature meter (in % of alarm triggering threshold) Counter for the number of times the device temperature alarm has been triggered
	Load impedance at the device terminals (1) Counter for the number of times the device load impedance alarm has been triggered
	RMS power meter at the channel output terminals Peak power meter at the channel output terminals
	RMS voltage meter at the channel output terminals Peak voltage meter at the channel output terminals
	Channel configuration. See (2)

(1) The real time measurement of load impedance and the activation of the relevant alarm are affected by the functional state of hardware and the installation cabling load (in case of crossing or open circuit in a speaker line, faulty amplifier, etc.), as well as by some audio program and volume transients produced over the time.

This may generate occasional measurement inaccuracies, leading to a false alarm triggering:

It is important to note that the load impedance alarm triggering can be due to a combination of temporary factors which are not abnormal in the installation. Check after triggering if the triggering condition is maintained over time, i.e. whether it is a false alarm or a true one requiring maintenance.

(2) Channel configuration.

Clicking on the configuration edit icon opens the parameter setting window:



For an NPA Series amplifier, adjustable parameters are:

- **Amplifier total Gain:** 26 / 32 / 38 dB
- **Vpeak Limiter Threshold:** maximum peak output voltage to which the equipment limiter reacts.
 - 40 to 119 V/OFF for NPA4000T
 - 40 to 99 V/OFF for NPA2500T
- **Maximum Load/Minimum Load:** between 0.2 and 100 ohms. Load measurement range outside which the load impedance alarm (LOAD) is triggered and counted (COUNT).
- **Enable Load Alarm:** enables/disables the triggering of the load impedance alarm.



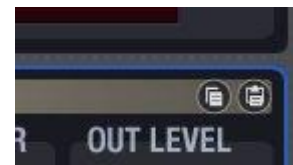





Additionally, there are two icons named “Copy Channel Data” and “Paste Channel Data” in the control window of each device channel (upper right part).

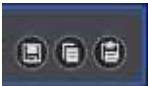

Clicking on “Copy Channel Data” in a channel (source channel) stores all parameters in a temporary memory.

Clicking on “Paste Channel Data” in a channel copies in the destination channel the parameters stored temporarily during the last “Copy Channel Data” operation, configuring the destination channel like the source channel.

8.1.1.2. NZA series detailed view

	<p>Device model and name</p>
	<p>Device power switch</p>
	<p>Status monitoring and alarms window. See Table of status monitoring and alarm icons</p>
	<p>Active Preset window: indicates the Preset currently active in the device (See section: Reduced view)</p>
	<p>Presets management icons:</p> <ul style="list-style-type: none"> • Save Device Preset (saves the current Preset) • Copy Device Preset (copies the current Preset) • Paste Device Preset (pastes the previously copied Preset) <p>(See section: Reduced view)</p>
	<p>Unit's <i>firmware</i> version</p>
	<p>Internal signal generator offering pink noise, white noise, sine wave and polarity check, with frequency adjustable between 10 and 20,000 Hz</p>
	<p>Device configuration. See (1)</p>

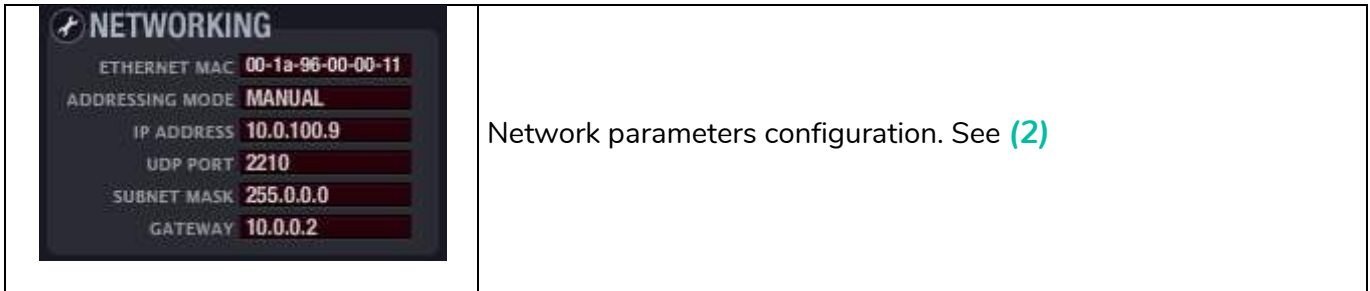

Network parameters configuration. See (2)

The top section of the detailed window provides the following items:



(1) Device configuration.

Clicking on the configuration edit icon opens the parameter setting window:

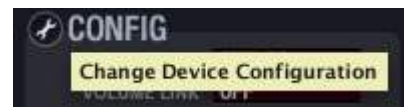

For NZA series amplifiers, adjustable parameters are:

- **Anticlip Mode:** SOFT/MID/HARD.

The protection system against saturation can operate in Soft, Mid or Hard mode.

- **Auto-Standby Mode:** ON/OFF. Enables/disables the automatic sleep mode (low-consumption) when no input signal is detected in any channel of the amplifier.

The next window shows the status of the adjustments made, as well as the number of accumulated operating hours of the device (*OPERATING TIME*):



(2) Network parameters configuration.



Exactly the same window and same parameters than those available with the Network Configuration option from the device context menu:





See section: [Creating an EclerNet Project](#)

The lower right section of the device channel window presents the following appearance for NZA Series:



	<p>Presence signal indicator (green) at the channel input</p>
	<p>Reading of the channel's volume control position on the hardware front panel. The position of this hardware control is a part of amplifier hardware and is not remotely adjustable from EclerNet Manager application. It determines the maximum signal level coming out from this amplifier channel output (0 dB means no attenuation or, which is equivalent, maximum volume).</p>
	<p>VCA port selector for remote control of channel volume, with a total of 4 or 6 ports, depending on the NZA amplifier model. Connecting for example a potentiometer to the VCA port of a channel of the amplifier allows you to remote control its volume.</p> <p>The maximum volume of a channel, whether it is assigned to a VCA port or not, will always be determined by the position of its hardware volume control.</p> <p>Note: a same VCA port can be assigned to several amplifier channels for a simultaneous remote control of all assigned channels.</p>

	<p>Metering of the control voltage detected at the selected VCA port (port B in the example). The metering is proportional to the volume control applied to the channel: 0 dB indicates maximum volume (zero attenuation due to VCA remote control).</p>
	<p>Channel configuration. See (1)</p>

(1) Channel configuration.

Clicking on the configuration edit icon opens the parameter setting window:

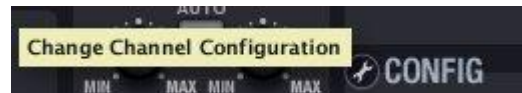

For NZA series amplifiers, adjustable parameters are:

- **Amplifier total Gain:** 26 / 32 dB
- **Output Mode:** SINGLE / BRIDGE / PARALLEL.
 - In SINGLE mode, a channel is absolutely independent of the other amplifier channels for all settings (input selection, volume, EQ, compressor settings, etc.). In this mode, each channel has its own control window in EclerNet Manager.
 - In BRIDGE and PARALLEL modes, channels are linked, set and controlled by pair, appearing in software as a unique control panel for each pair of linked channels. Possible pairs are always made of consecutive channels: 1&2, 3&4, 5&6 (depending on NZA device, whether 4 or 6 channels).
- **Compressor Mode:** COMPRESSOR / VPEAK LIMITER (voltage peak limiter).

It determines how the GUI of the channel compressor will look, with a choice between the aspect of a classic compressor and a voltage peak limiter for the output signal of the amplifier (see section **COMPRESSOR section**).

8.1.2. INPUT

The input section contains the following controls:

- **SELECT:** allows you to select this channel input amongst available sound sources:
 - **IN1 / IN2, etc.:** amplifier's analogue input 1, 2, etc. (and also IN1+2, IN3+4, etc., for NZA series)
 - **DIG IN1 / DIG IN2:** amplifier's digital input 1 or 2 (available in NPA series)
 - **GEN:** internal generator signal, controlled from the GENERATOR panel.
- **LINK:** links channels for simultaneous operation (available in NPA series)
- **VOLUME:** channel volume, adjustable between $-\infty$ and 0dB. There are two Vu meter-type level indicators to the right of the channel fader: the left bar displays the input signal level and the right one the channel output signal level after processing.
- **SOLO:** mutes all device channels except those with SOLO function enabled.
- **MUTE:** mutes this channel audio signal.
- **INVERT:** allows the input signal phase to be inverted (180 degrees shift).



8.1.3. CROSSOVER

The CROSSOVER section contains the FILTER TYPE and FREQUENCY parameters for each of the two filters (low-pass and high-pass) composing the crossover. It splits the audio frequency spectrum in two parts, creating the two bands usually used in two-way speakers.

- **FILTER TYPE:** allows you to select the crossover filter type. You can select one of the following filter types.
 - Butterworth 6, 12, 18 or 24 dB/oct
 - Bessel 12, 18 or 24 dB/oct
 - Linkwitz-Riley 12 or 24 dB/oct
- **FREQUENCY:** is made of a potentiometer and a numerical value to adjust the filter cut-off frequency within the 20 Hz - 20 kHz range.



8.1.4. PARAMETRIC EQ

This section groups the eight parametric filters available per channel, very useful for a precise correction of the frequency response.

Available parameters are described below (the parameters are always displayed for one of the 8 filters, the one with its numeric indicator filled in white, as filter #2 in the image):

- **ON/OFF:** turns on/off the parametric EQ, affecting all filters from this section. When the value is OFF (top left button greyed out), there is no filter processing (all filters are bypassed). In the opposite case (green button), operation is determined by the other parameters.
- **FILTER TYPE:** type of filter used. You can select one of the following filter types (adjustable controls for each filter type are shown between brackets):
 - **Bypass:** filter not used.
 - **Parametric EQ (FREQUENCY, GAIN, Q):** classic parametric equalizer filter with adjustable central frequency (between 20 Hz and 20 kHz), gain or attenuation at

central frequency (between +12 dB and -60 dB) and bandwidth (1/Q, Q between 0.3 and 200).

- **Low-Shelf and High-Shelf with a 6 or 12 dB/oct slope (FREQUENCY, GAIN):** shelving type filters with adjustable cut-off frequency (between 20 Hz and 20 kHz) and gain or attenuation (between +12 dB and -60 dB).
- **Low-Pass and High-Pass with a 6 or 12 dB/oct slope (FREQUENCY):** these are low-pass and high-pass filters with adjustable cut-off frequency (between 20 Hz and 20 kHz).
- **All-Pass order 1 and 2 (FREQUENCY, Q in order 2):** all-pass filters that do not affect the signal amplitude, but the phase at certain frequencies (in contrast with delay, which changes phase at all frequencies). This type of filter is mainly used to compensate for phase errors in speakers or other causes, such as phase shifts introduced by the crossover.

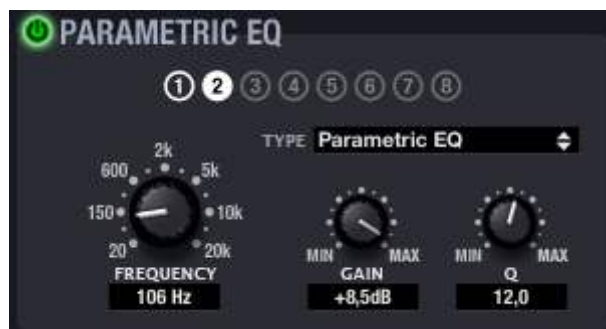

8.1.5. COMPRESSOR

The compressor section offers a processing of the input signal dynamic behaviour, allowing the output intensity to be controlled not to exceed certain levels. Available settings are:

- **ON/OFF:** turns the compressor on/off (green button/grey button). When in OFF mode, the rest of the section controls are disabled.
- **THRESHOLD:** compression threshold. Composed of a potentiometer and a numerical value, and used to specify the input signal level at which compression begins to occur. This parameter ranges from +18 dB to -36 dB.
- **RATIO:** compression ratio. It also includes a potentiometer and its associated numerical value. This parameter determines the output volume reduction ratio when the input signal level rises above the threshold. A value of 1:1 states that the signal level does not undergo changes, while the extreme value of inf:1



represents a signal limiter, with which any signal above the threshold will be limited to that threshold level.

- **ATTACK** (potentiometer and numerical value): attack time. Determines the time the compressor takes to respond when the input level rises above the threshold. The range extends from 0.1 ms to 500 ms.
- **RELEASE** (potentiometer and numerical value): determines how quickly the compressor stops operating once the signal input level drops below the threshold. In this case, the range covers from 1 ms to 5 s.

Setting the compressors' *ATTACK* and *RELEASE* times correctly is not an easy task: too short release or attack times result in excessive and perceptible low frequencies distortion; on the other hand, too long times could make a limiter useless if damages already occurred before limitation starts.

In order to help you to correctly set these values, the *AUTO* parameter automatically select *ATTACK* and *RELEASE* values, using the crossover high-pass filter cut-off frequency as internal reference.

When *AUTO* is enabled, *ATTACK* and *RELEASE* controls editing is disabled, but used values are still displayed.

Additionally, some devices (NZA series) can display the compressor function in voltage peak limiter mode, changing the GUI appearance, as shown in the attached image.

In this mode, the limiting threshold appears in volt units and *RATIO*, *ATTACK* and *RELEASE* controls are disabled.



8.1.6. DELAY

The *DELAY* section allows you to set an independent delay time for each channel, which is applied between input and output.

The delay time can be specified in different units, selected with *UNITS* parameter. Available units are milliseconds, seconds, centimetres and meters. *DELAY* can be set between 0 and 1000 milliseconds.



To avoid weird and annoying noises in the output signal, the value change made with the *DELAY* potentiometer is not effective until the mouse button is released. At that time audio will be temporarily muted (for a variable time, depending on the delay value used) for the new setting to be effective.

8.1.7. Copying and pasting settings between channels

Copy Channel Data and Paste Channel Data icons () , located in the upper right corner of the control panel of each device channel, are used to copy all settings from one amplification channel in a temporary memory and paste them in another amplification channel.

Considerations:

- Channel copying and pasting can be done within a single device or from a device channel to a channel of another device
- In the latter case, copying and pasting operation can only be made between channels of the same device series (you cannot copy a channel from an NPA amplifier and paste it into a NZA amplifier, or vice versa)
- To clone the full configuration of all channels from one device to another, use Copy Device Preset and Paste Device Preset from the icons to the right of the preset name in the upper section of the device configuration

8.2 NXA series, self-powered digital audio manager

8.2.1. Introduction to NXA series

NXA is a series of "all-in-one" digital audio devices: a multichannel self-powered digital manager, an evolution of the EclerNet NZA series of amplifiers integrating a digital audio matrix. In some projects, a digital amplifier with Ethernet/RS-232 remote control is essential, yet insufficient to meet all requirements, as input signal mixing, source selection, priorities, self-diagnostics for the correct operation of the device, user control interface, etc. Adding a digital matrix to the equipment list may exceed the budget. This is where the NXA series fits perfectly: an amplifier/processor hybrid digital device, a complete audio solution that provides multiple methods of remote control with a long list of features.

NXA device programming is performed with the EclerNet Manager application, either via a CAT5 point-to-point connection (directly from the computer to the NXA device) or from a remote point of the Ethernet network it is linked to.

The remote management for NXA and in general for any EclerNet compatible device (as NZA or NPA amplifiers, or MIMO88 matrix) can be done in the following ways:

- with the EclerNet Manager application, either via a CAT5 point-to-point connection (directly from the computer to the NXA) or from a point of the Ethernet network it is linked to
- from EclerNet clients of Ethernet Manager, or UCPs (User Control Panels): several simultaneous web clients, each with its own custom control panel, and EclerNet Manager acting as a web server. EclerNet Manager allows to create such control panels in a very simple and intuitive manner
- from external "third-party" control devices (Crestron®, AMX®, Extron®, VITY®, Medialon®, RTI®, etc.), using for this the **TP-NET** Ecler communication protocol integrated in the NXA series and the Ethernet or **RS-232** communication of the device

The NXA has 4 or 6 analogue audio inputs and 4 or 6 amplified outputs (4 or 6 channels, depending on model), from 80W per channel up to 400W per channel (depending on model). All inputs are balanced, at a nominal line level, while the amplified outputs can be set to work in SINGLE, PARALLEL or BRIDGE mode.

With EclerNet Manager you can configure the NXA for all types of audio processing tasks (DSP or Digital Signal Processing) on incoming signals, such as:

- Independent audio input mixer for each channel of the device (mixing matrix), allowing to generate a different mixing than the ones made in the other channels
- Independent controls per channel: VOLUME, MUTE, SOLO, PHASE INVERSION, MAX. VOL (upper volume limit) and MIN. VOL (lower volume limit)
- LP and HP crossover filters, up to 4th order, per channel
- Bank of 8 parametric EQ filters, per channel
- Compressor with THRESHOLD, COMP. RATIO, ATTACK, RELEASE, and MAKE-UP KNEE GAIN settings, per channel
- Delay, up to 1000 milliseconds, per channel
- DUCKER function (priority): an input can be configured with highest priority, being able to reduce and replace the audio content of any channel, when its signal exceeds the detection threshold. This feature is vital in emergency/evacuation systems, which should play a specific alarm and/or evacuation message instead of the regular audio program when an emergency scenario is detected
- 5 configuration memories (presets) are available

As inputs for hardware control devices, the NXA has 4 or 6 GPI ports (depending on model), or *General-Purpose Inputs*, 0-10 VDC. These control inputs can be connected to external devices such as contact closures, potentiometers, Ecler WPM / WPA series panels, 0-10 VDC voltage sources, etc.

The GPI inputs can be programmed to control certain functions of the NXA device from external hardware devices:

- recall one of the 5 available Presets (through a WPMVOL-SR, WPAVOL-SR or WPTOUCH wall panel)
- select a sound source in a preset list of the unit audio inputs for one channel or multiple channels simultaneously (through a WPMVOL-SR or WPTOUCH wall panel)
- adjust the audio volume of one or more inputs, or one or more outputs (through a WPMVOL, WPAVOL, WPMVOL-SR, WPAVOL-SR or WPTOUCH wall panel)

Other remarkable features of the NXA series are:





- TP-NET external remote-control protocol, via Ethernet and RS-232 (compatible with Crestron®, AMX®, RTI®, VITY®, etc.)
- POWER ON/OFF button and/or front panel volume controls deactivated by software, preventing unauthorized tampering
- Front panel volume controls can be assigned to one or more audio inputs or one or more amplified outputs
- Self-diagnostics function for the correct operation of the amplifier, with FAULT relay: allows the device failure detector to switch to an external redundant system, replacing the faulty unit with a spare one
- Integrated "Anti-clip" system

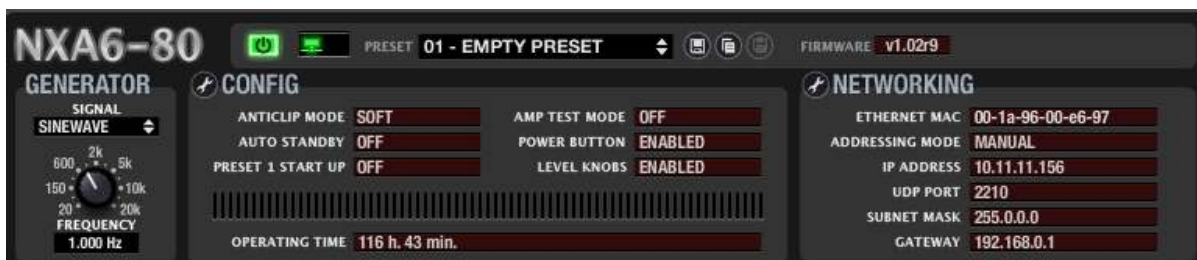

For more information about MIMO88's hardware, refer to the product manual.

8.2.2. NXA Series detailed view, general sections of the device

The top section of the detailed window provides the following items:

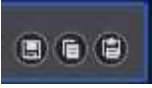

	Device model and name
	Device power switch
	Status monitoring and alarms window. See Table of status monitoring and alarm icons
	Active Preset window: indicates the Preset currently active in the device

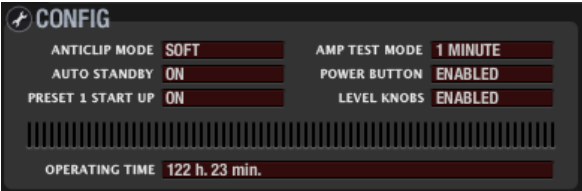
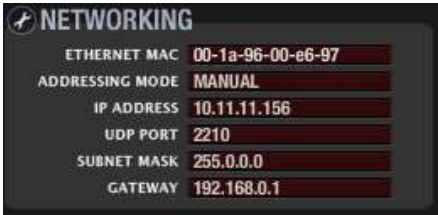
	<p>Presets management icons:</p> <ul style="list-style-type: none"> • Save Device Preset: saves the current Preset in memory (click on the mouse left button) or in a folder on your PC (click on the mouse right button) • Copy Device Preset: copies the current Preset • Paste Device Preset: pastes the previously copied Preset
	<p>Unit's firmware version</p>
	<p>Internal signal generator providing pink noise, white noise, sine wave and polarity check, with frequency adjustable between 10 and 20,000Hz</p>
	<p>Device configuration. See (1)</p>
	<p>Network parameters configuration. See (2)</p>

(1) Device configuration.

Clicking on the configuration edit icon opens the parameter setting window:



The adjustable parameters are:

- **Anticlip Mode:** SOFT/MID/HARD.

The protection system against saturation can operate in SOFT, MID, or HARD mode.

- **Amp Test Mode:** OFF / 1 MINUTE / 1 HOUR

Defines the frequency of the unit self-diagnostic test, which confirms its correct operation, checking the amplified audio signal presence at its outputs; if no signal is detected, the rear panel FAULT relay is switched on

- **Auto-Standby:** ON/OFF.

Enables / disables the automatic sleep mode (low-consumption) when no input signal is detected on any of the amplifier channels.

- **Preset 1 Start Up:** ON/OFF

Allows to automatically retrieve the preset number 1 stored in the unit memory each time the equipment is initialized (the power supply is switched off and on again). This ensures the same starting conditions for your setup each time the device is turned on (at the beginning of the day, etc.)

- **Enable Power Button:** ON/OFF

Allows to enable or disable the front panel POWER switch, so in the latter case the device is protected against accidental on/off switching or unauthorized use of the unit

- **Enable Level Knobs:** ON/OFF

Allows to enable or disable the front panel LEVEL rotary knobs, so in the latter case the device is protected against accidental or unauthorized adjustment of the unit's inputs and outputs

The next window shows the status of the adjustments made, as well as the number of accumulated operating hours of the device (*OPERATING TIME*):

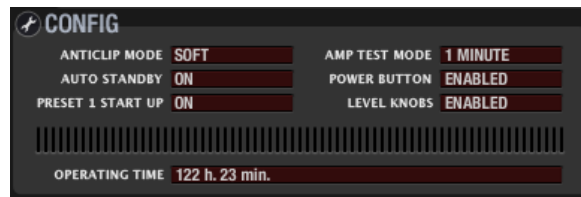

(2) Network parameters configuration.

Exactly the same window and same parameters than those available with *Network Configuration* in a device context menu:



Below this, we can find 3 tabs for the detailed configuration of:

- front panel **KNOBS** and rear panel **GPIS**
- **VIRTUAL** buttons and volume controls from UCP panels
- **DUCKER** (priority triggered by audio signal level) section

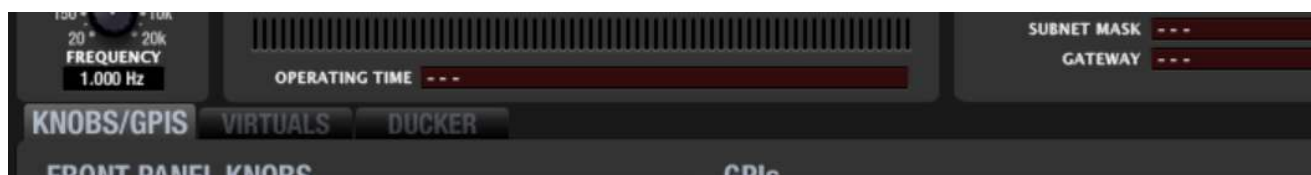

Section **KNOBS/GPIs** allows configuring the function to be performed by the LEVEL rotary knobs on the front panel, as well as the function of the rear panel GPI ports:

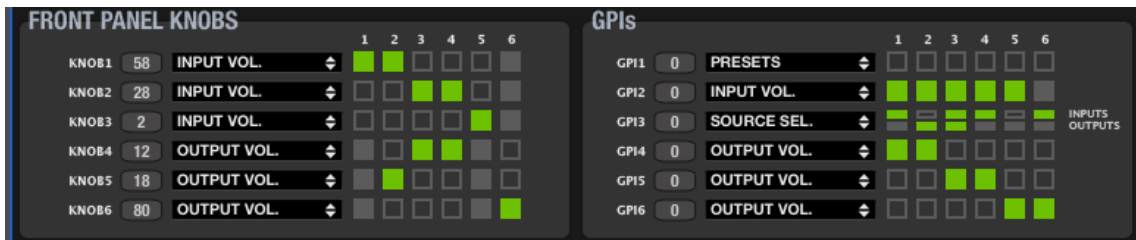

The front panel LEVEL controls are displayed as KNOB 1 to 4 (or 1 to 6, depending on models). To the right of each of them is displayed the value (=position) of the front panel **LEVEL** hardware knob, read in real time, from 0 to 100 (in this example 58, 28, 2, etc.)

For each of them, the drop-down menu allows to select the control function of certain audio inputs or outputs of the unit:

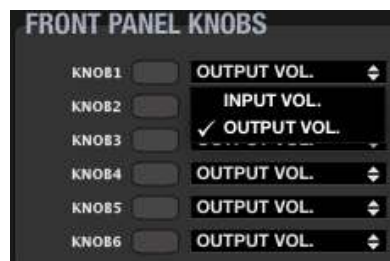

After selecting the type of volume control (INPUTs or OUTPUTs), the inputs or outputs simultaneously affected by each control knob have to be checked in boxes 1, 2, 3, 4, 5 and 6. Clicking with the mouse activates (green) or deactivates them. In the above example, we see the following control settings:

- LEVEL 1 controls the inputs 1 and 2 levels
- LEVEL 2 controls the inputs 3 and 4 levels
- LEVEL 3 controls the input 5 level
- LEVEL 4 controls the outputs 3 and 4 levels
- LEVEL 5 controls the output 2 level
- LEVEL 6 controls the output 6 level

Note: a LEVEL control can simultaneously control multiple inputs and outputs, but **NOT the other way around**: the application automatically manages that one input or output is associated with a single control knob, and not simultaneously with several ones.

The unit's **GPI** ports (0-10 VDC control ports) on the rear panel are displayed as GPI 1 to 4 (or 1 to 6, depending on models). To the right of each of them is displayed the value of the signal (voltage) received on the central pin of each GPI port, read in real time (0 to 100 scale). A WPMVOL / WPaVOL or WPMVOL-SR / WPaVOL-SR wall panel, or similar, connected to a GPI will deliver this full range, 0 to 100 values, when gestured.

For each of them, the drop-down menu allows to select the control function from the following options:

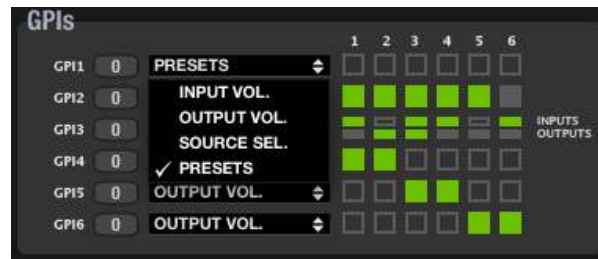

- **INPUT VOL.:** volume control of one or more audio inputs of the unit. The boxes of the targeted inputs must be checked: clicking with the mouse activates (green) or deactivates them. In the following example GPI #2 controls the volume of inputs 1 and 2:



- **OUTPUT VOL.:** volume control of one or more audio outputs of the unit. The boxes of the targeted outputs must be checked: clicking with the mouse activates (green) or deactivates them. In the following example GPI #4 controls the volume of the outputs 1, 3, 4 and 6:

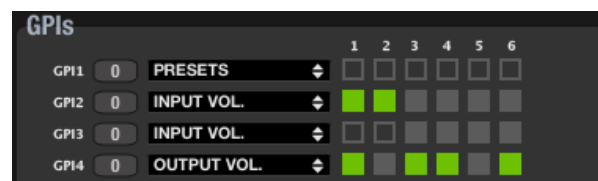

- **SOURCE SEL.:** selection of input sources for one or more unit channels, using the 5-positions selector knob of a WPMVOL-SR / WPaVOL-SR or similar wall panel. The boxes of the inputs composing the carousel of selectable sound sources (INPUTS, upper half of the boxes to the right of the drop-down menu), and the outputs that will be affected by this selection of sources (OUTPUTS, lower half of the boxes to the right of the drop-down menu) must be checked: clicking with the mouse activates (green) or deactivates them.

From the following example, we can deduce the following configuration:

GPIs		1	2	3	4	5	6	
GPI1	0 PRESETS							
GPI2	0 INPUT VOL.							
GPI3	0 SOURCE SEL.		■	■	■	■	■	INPUTS OUTPUTS
GPI4	0 OUTPUT VOL.							
GPI5	0 SOURCE SEL.	■	■		■	■	■	INPUTS OUTPUTS
GPI6	0 OUTPUT VOL.							

- GPI3: allows to select sound sources for outputs 2 and 3. The sound sources are selected using the selector knob of a WPmVOL-SR / WPaVOL-SR unit, connected to GPI3, as follows:
 - Position 0: OFF (no source)
 - Position 1: input 1
 - Position 2: input 3
 - Position 3: input 4
 - Position 4: input 6
- GPI5: allows to select sound sources for outputs 4 and 6. The sound sources are selected using the selector knob of a WPmVOL-SR / WPaVOL-SR unit, connected to GPI5, as follows:
 - Position 0: OFF (no source)
 - Position 1: input 1
 - Position 2: input 2
 - Position 3: input 5
 - Position 4: OFF

Note: the carousel of options for one of these selector knobs may include a maximum of 4 inputs, so that the first position of the hardware selector (WPmVOL-SR or similar) corresponds to OFF (no input selected). The next positions, up to a maximum of 4, consecutively correspond to the inputs being part of the carousel of selectable sound sources (INPUTS, upper half of the boxes to the right of the drop-down menu). If less than 4 options are selected, the last selector positions without associated input also correspond to the OFF selection (no input), as with the GPI 5 in the example above.

Note: when a LEVEL control **and** a GPI are associated to control the volume of the same input or output, both are concatenated ("in series"), so that the highest level of one of them at a given time will determine the maximum volume control that can reach the other when set to its maximum position. Examples, with KNOB 1 and GPI 1 controlling the channel 2 volume:

- GPI 1 at 100%: moving LEVEL 1 can control the channel 2 volume from 0 to 100%
- KNOB 1 at 100%: acting on GPI 1 can control the channel 2 volume from 0 to 100%
- GPI 1 at 75%: moving LEVEL 1 can control the channel 2 volume from 0 to 75%
- KNOB 1 at 75%: acting on GPI 1 can control the channel 2 volume from 0 to 75%
- etc.
- **PRESETS:** recall of one of the five presets in the NXA memory, using the 5-way selector knob of a WPmVOL-SR / WPaVOL-SR or similar wall panel.
 - Selector position 0: preset 1 recall
 - Selector position 1: preset 2 recall
 - Selector position 2: preset 3 recall
 - Selector position 3: preset 4 recall
 - Selector position 4: preset 5 recall

The TAB named **VIRTUALS** allows to link "A" and "B" VIRTUAL controls of an NXA unit to virtual buttons and volume controls (faders, knobs) in UCP panels.



Options are:

- Just control an INPUT or OUTPUT (or group of inputs or outputs) volume with a virtual fader or rotary knob in a UCP. In this case, just proceed to program "A" virtual controls, exactly in the same way as the front panel hardware knobs of the NXA, explained just above these lines:



In this case, "B" virtuals are not available, as won't have any function.

- Combined source selector + volume control functions:
 - Use a UCP button as a source selector (or input selector) for one or several output channels (for this purpose use "A" VIRTUALS: 1A, 2A, 3A, 4A, 5A, 6A)
 - Volume control of the selected source for the selected destination channels (for this purpose use "B" VIRTUALS: 1B, 2B, 3B, 4B, 5B, 6B)

You can create UCP panels that include virtual controls for the above purpose, like in this example: a control panel that will allow the user to select a sound source from 4 choices and adjust the volume at which this source will be played in a given output zone. This is equivalent to selecting an input from 4 options and adjusting the matrix "crosspoint" level of the selected source for the desired channel or channels in an NXA unit:



In the following example, the NXA VIRTUALS section is programmed like this, selecting for each "A" virtual control which INPUTS will make part of the selection list (IN1, 2, 3 and 4 in the example, seen as green boxes) and for which channel (or NXA's outputs) will be this selection effective (just one channel or OUTPUT in the example, seen as green box):

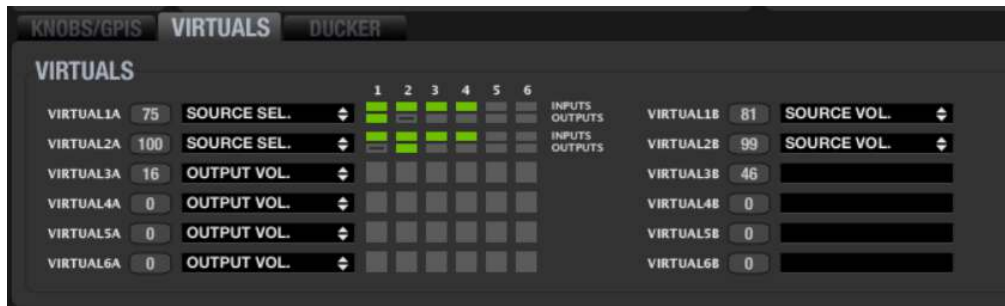

In the above example, the configuration shows:

- VIRTUAL 1A allows to select IN1, 2, 3 or 4 as a sound source for output channel 1, and VIRTUAL 1B allows to adjust the volume of the selected source for output channel 1
- VIRTUAL 2A allows to select IN1, 2, 3 or 4 as a sound source for output channel 2, and VIRTUAL 2B allows to adjust the volume of the selected source for output channel 2

...we can build one panel to manage music sources and volume for OUT1, connected to the loudspeakers in an office, Office #1, and another panel to manage the same for OUT2, connected to the loudspeakers in Office #2, like these ones:



Positioning the mouse cursor on top of each green rectangle a tooltip will appear, indicating the numerical value of the virtual control that will select this source for this channel:



In the above example, these values are:

IN1: 25 / IN2: 50 / IN3: 75 / IN4:100

...and the picture shows as well this information:

- the NXA channel affected by this source selection with VIRTUAL 1A will be OUTPUT1
- the NXA channel affected by this source selection with VIRTUAL 2A will be OUTPUT2

Then, virtual buttons to select sources (IN1 to IN4) in the UCP panel for OUTPUT1 (Office 1) must be programmed linking them to VIRTUAL 1A, like this:

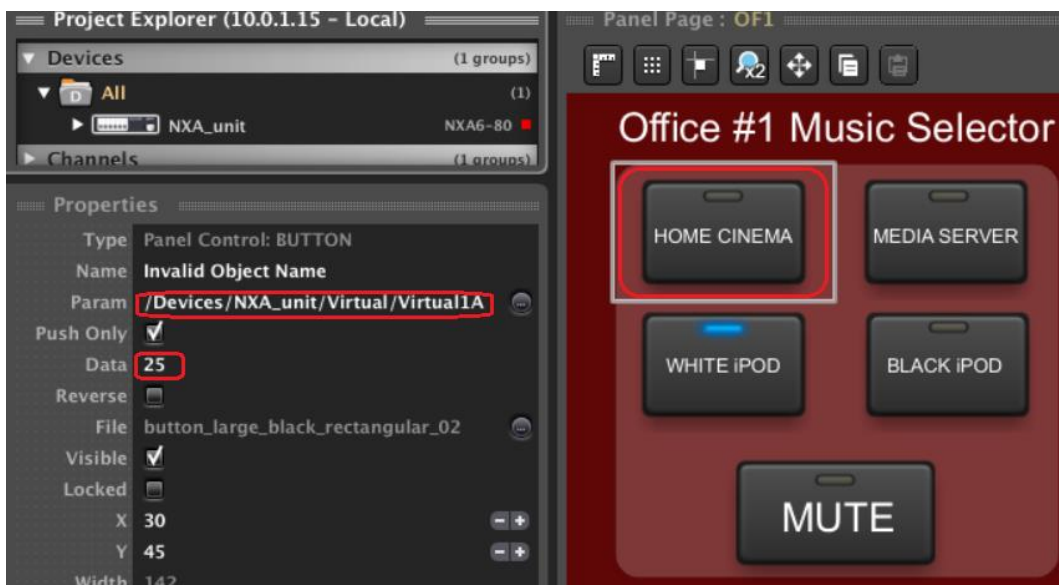

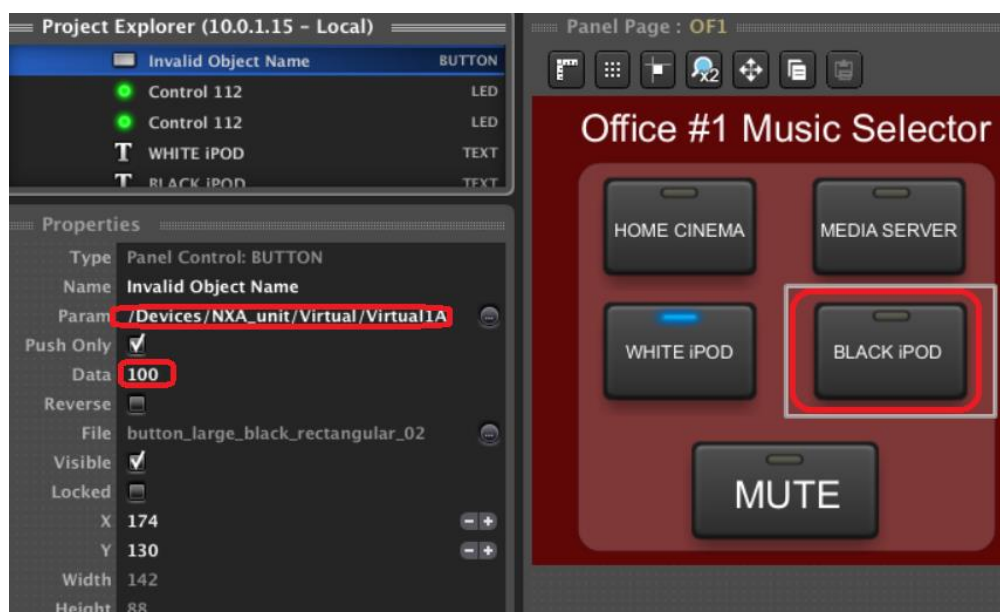
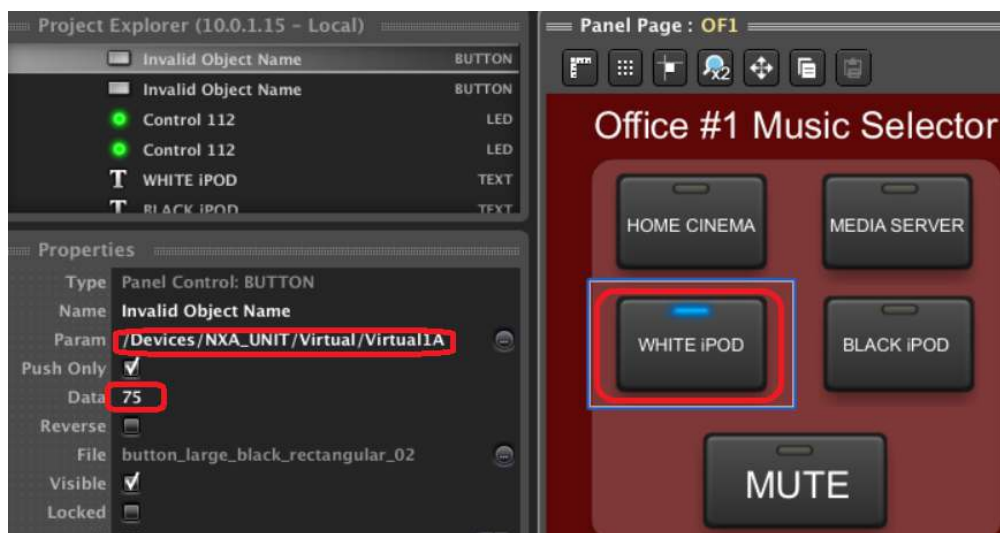
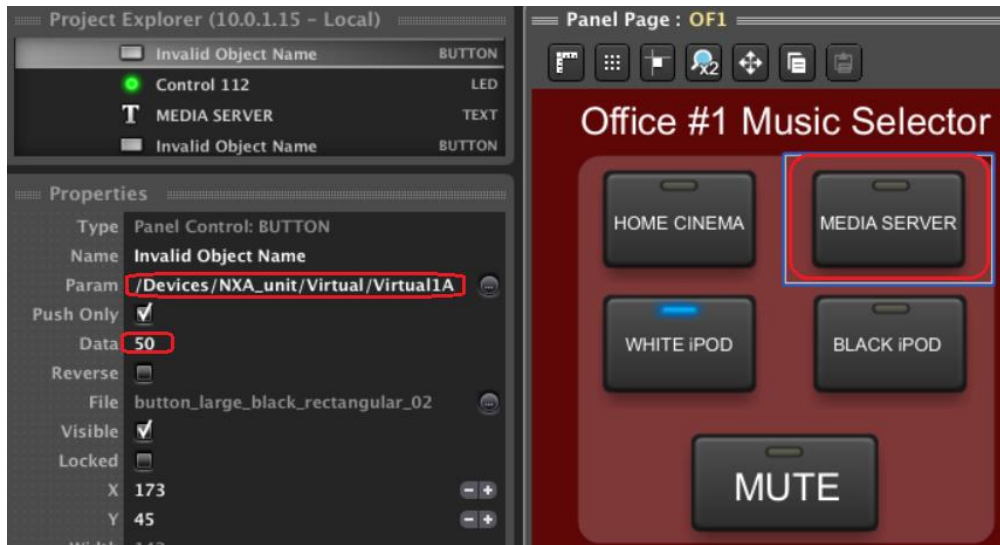

And the fader to control the selected source in the above panel must be linked to VIRTUAL 1B, like this:

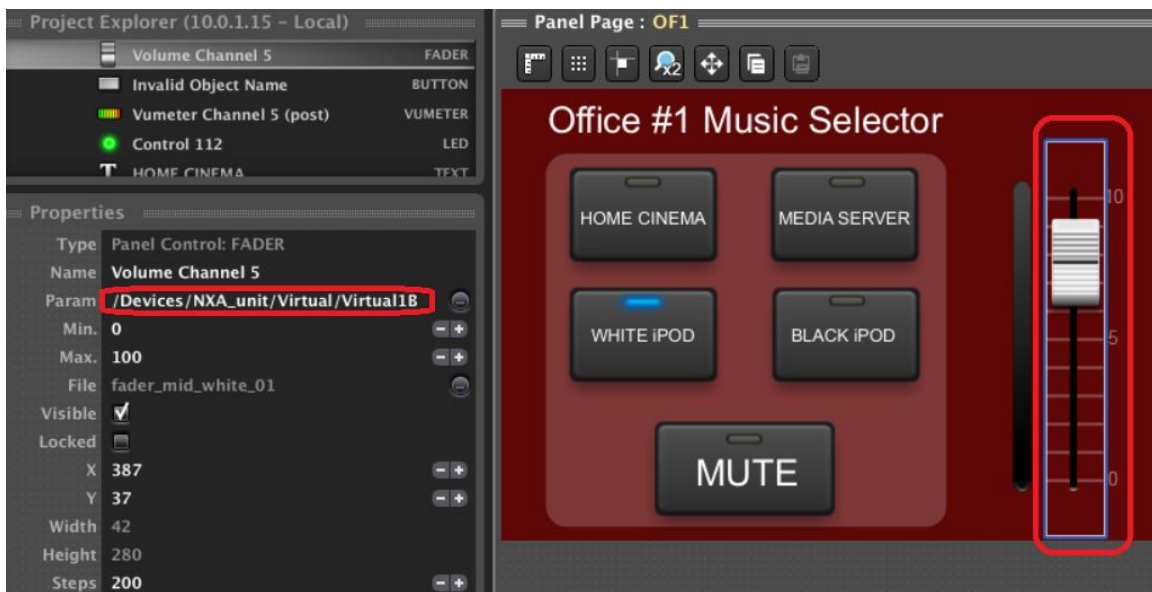

Now let's repeat all the above for the second UCP panel (Office 2), but this time using VIRTUALS 2A and 2B:

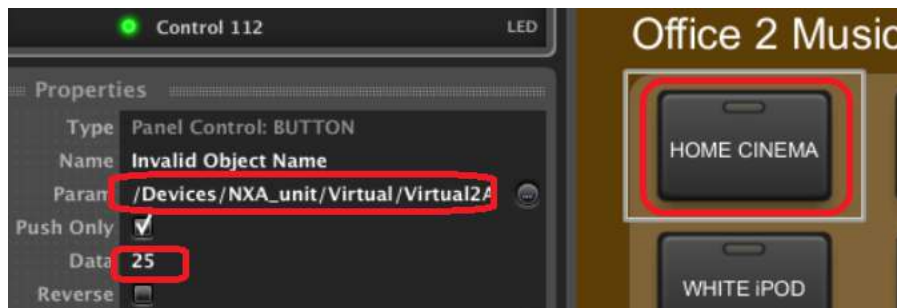

....and values 75 and 100 for the other 2 selection buttons. The volume fader for Office #2 UCP panel should be configured like this:



The third tab here is the **DUCKER** one. This module gives priority to one of the device's audio input compared to other active signals in the output channels (zones) chosen as a destination, attenuating these signals ("override") and thus allowing the diffusion of top priority audio messages or other content.



The INPUT selector defines the audio input your microphone, audio player or sound source will be connected to in order to act as a trigger of the DUCKER function. The list shows the 4 or 6 available inputs, depending on model.

Note: the NXA series inputs accept line level signals, so the DUCKER function requires this type of signal from the device to be connected to them.

The destination zone keys in the central part of the section (1 to 4 or 1 to 6, depending on model) allow selecting the unit's output channels (destination zones) for the DUCKER module with a mouse click. If a zone is selected (green LED indicator), the DUCKER module will affect it when the input signal exceeds the activation threshold.

The LED indicator on the left of the module indicates the active or inactive state of the DUCKER function (activation threshold exceeded). It lights up in green when the DUCKER function is active.

The module rotary knobs are used to adjust the operation of the DUCKER function:

- **THRESHOLD:** activation threshold. When the module's input signal (INPUT selector) exceeds this threshold, the DUCKER function is activated, sending the signal to the destination zones and attenuating the other audio signals sent to the same zones (-80 to 0dB)
- **DEPTH:** attenuation applied on the rest of the signals sent to the destination zone(s) during the time the DUCKER function is active (0 to 80dB)
- **ATTACK:** attack time. Determines the time the DUCKER takes to respond when the level rises above the threshold (activating the attenuation of other signals in the destination zones). The range extends from 5 ms to 2 sec.
- **HOLD:** amount of time the DUCKER function remains active once the signal falls back below the detection threshold. The setting range extends from 10 ms to 3 sec.
- **RELEASE:** determines the time elapsed until attenuation stops after the time fixed for HOLD. In this case, the range extends from 50 ms to 3 sec.

8.2.3. NXA series detailed view, device channels

The detailed view of a NXA device displays the configuration of the unit's 4 or 6 channels (depending on model). Each channel offers the following parameters and settings:

8.2.3.1. INPUTS

First find the input selection activated for the channel in question, and their relative mixing levels. Here is a picture of the matrix mixer for each unit channel.

With a double click on the knobs, each input can be activated (white knob) or muted (grey knob) in the corresponding mixing channel. The knob setting (click, hold and drag the mouse up / down) defines the level of each input in the mix.

In the example on the right, the channel mix includes the internal generator (maximum level, 0 dB), input 1 (-24.7 dB), input 2 (-15.3 dB), input 5 (0 dB) and input 6 (-5.3 dB).

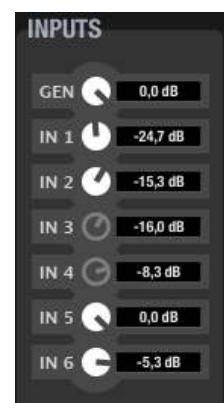

8.2.3.2. VOLUME, SOLO, MUTE, POLARITY

Volume fader and additional controls:

- **VOLUME:** channel volume, adjustable from -infinity to 0 dB. There are two VU-meter bargraphs to the right of the channel fader: the left bar displays the channel



input signal level and the right one the output signal level of the same channel after processing.

- **SOLO**: mutes all device channels except those whose SOLO function is enabled.
- **MUTE**: mutes audio for this channel.
- **POLARITY**: allows the input signal phase to be inverted (180 degrees shift).

8.2.3.3. CROSSOVER

The **CROSSOVER** section contains the **FILTER TYPE** and **FREQUENCY** parameters for each of the two filters (low-pass and high-pass) composing the crossover. It splits the audio frequency spectrum in two parts, creating the two bands generally used in two-way speakers.



- **FILTER TYPE**: allows you to select the crossover filter type. You can select one of the following filter types.
 - Butterworth 6, 12, 18 or 24dB/oct
 - Bessel 12, 18 or 24dB/oct
 - Linkwitz-Riley 12 or 24dB/oct
- **FREQUENCY**: is composed of a potentiometer and a numerical value to adjust the filter cut-off frequency within the 20Hz - 20kHz range.

8.2.3.4. PARAMETRIC EQ

This section groups the eight parametric filters available per channel, very useful for a precise correction of the frequency response.

Available parameters are described below (the parameters are always displayed for one of the 8 filters, the one with white background for its number indicator, as filter #2 in the image):

- **ON/OFF:** turns on/off the parametric EQ, affecting all filters from this section. When it is OFF (top left button greyed out), there is no filter processing (all filters are bypassed). In the opposite case (green button), operation is determined by the other parameters.
- **FILTER TYPE:** type of filter used. You can select one of the following filter types (adjustable controls for each filter type are shown between brackets):
 - **Bypass:** filter not used.
 - **Parametric EQ (FREQUENCY, GAIN, Q):** classic parametric equalizer filter with adjustable central frequency (between 20Hz and 20kHz), central frequency gain or attenuation (between +12dB and 60dB) and bandwidth (1/Q, Q between 0.3 and 200).
 - **Low-Shelf and High-Shelf with a 6 or 12 dB/oct slope (FREQUENCY, GAIN):** shelving type filters with adjustable cut-off frequency (between 20Hz and 20kHz) and gain or attenuation (between +12dB and -60dB).
 - **Low-Pass and High-Pass with a 6 or 12 dB/oct slope (FREQUENCY):** these are low-pass and high-pass filters with adjustable cut-off frequency (between 20Hz and 20kHz).
 - **All-Pass order 1 and 2 (FREQUENCY, Q in order 2):** all-pass filters that do not affect the signal amplitude, but the phase at certain frequencies (in contrast with delay, which changes phase at all frequencies). This type of filter is mainly used to compensate for phase errors in speakers or other causes, such as phase shifts introduced by the crossover.

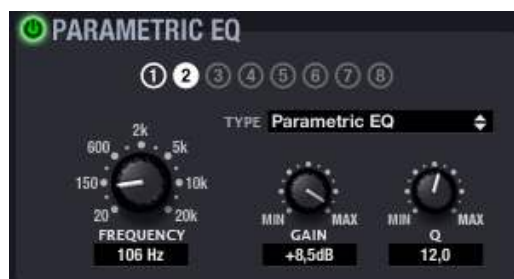

It is recommended to use the graphical representation of the channel EQ to help you during the adjustment (Show/Hide Graph icon in the lower right corner of the EclerNet Manager application window):



NOTE (from v4 onwards): New EQ export / import feature that allows to export the EQ section from devices like MIMO88, MIMO88SG, MIMO1212SG, MIMO88 CONFERENCE, NXA series, etc. to a *.eqs file that can be imported in other devices:

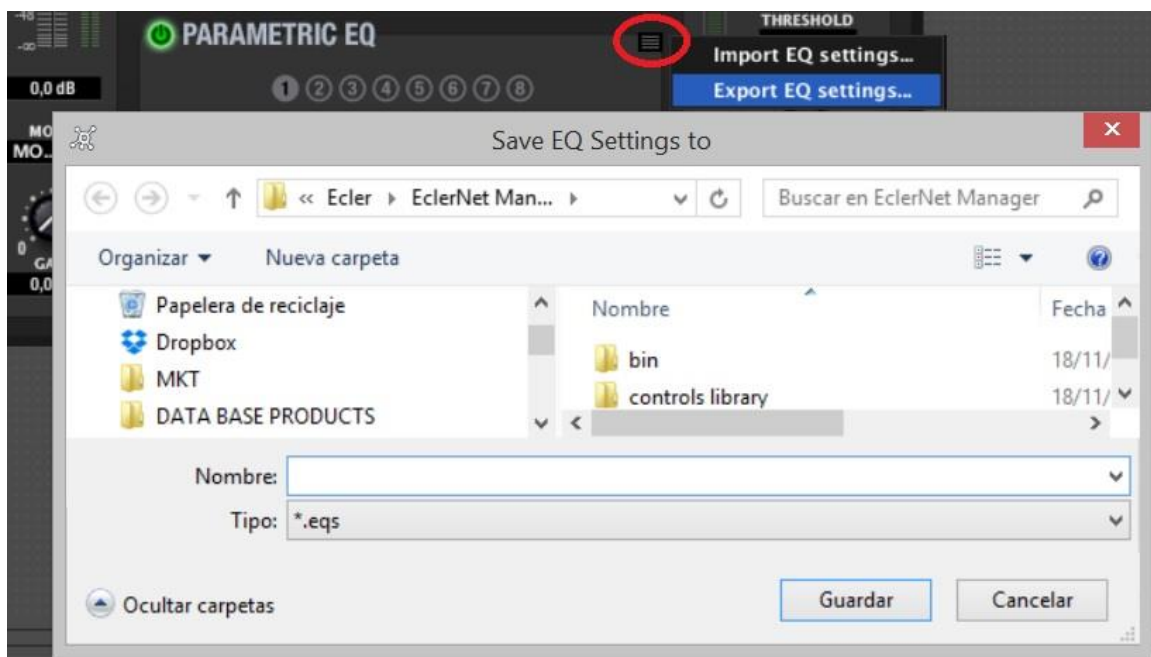

- It's available just when the EQ section is ON
- Exporting an EQ set with 8 filters (for instance, MIMO88 output EQ), for instance, to a device that supports 6 filters (like NXA units) will result in ignoring filters 7 and 8

8.2.3.5. COMPRESSOR

The compressor section offers a dynamic behaviour processing of the channel signal, allowing the output intensity to be controlled not to exceed certain levels. Available settings are:

- **ON/OFF:** turns the compressor on/off (green button/grey button). In OFF mode, the other section controls are disabled.
- **THRESHOLD:** compression threshold. Composed of a potentiometer and a numerical value, and used to specify the input signal level at which compression begins to occur. This parameter ranges from +18dB to -36dB.
- **RATIO:** compression ratio. It also includes a potentiometer and its associated numerical value. This parameter determines the output volume reduction ratio when the input signal level rises above the threshold. A value of 1:1 states that the signal level does not undergo changes, while the extreme value of inf:1 represents a signal limiter, with which any signal above the threshold will be limited to that threshold level.
- **ATTACK** (potentiometer and numerical value): attack time. Determines the time the compressor takes to respond when the input level rises above the threshold. The range extends from 0.1 ms to 500 ms.
- **RELEASE** (potentiometer and numerical value): determines how quickly the compressor stops acting once the signal input level drops below the threshold. In this case, the range covers from 1msec to 5sec.
- **KNEE (HARD / SOFT):** determines how compression is applied in the transition zone or "knee" once the compression threshold has been crossed, giving a response curve with a rounded edge or a sharper angle
- **MAKE-UP gain:** additional gain applied to the channel signal once compressed, with the aim of recovering the decibels lost due to the compression, for a maximum signal level



Setting compressors' *ATTACK* and *RELEASE* times correctly is not an easy task: too short release or attack times result in excessive and perceptible low frequencies distortion; on the other hand, too long times could make a limiter useless if damages already occurred before limitation starts.

In order to help you to correctly set these values, the *AUTO* parameter automatically select *ATTACK* and *RELEASE* values, using the crossover high-pass filter cut-off frequency as internal reference.

When *AUTO* is enabled, the editing with *ATTACK* and *RELEASE* controls is disabled, but used values are still displayed.

Additionally, the compressor function can be displayed in voltage peak limiter mode, changing the GUI appearance, as shown in the screenshot beside.

In this mode, the limiting threshold appears in volt units and the other controls are disabled (right screenshot).



8.2.3.6. DELAY

The *DELAY* section allows you to set an independent delay time for each channel, which is applied between input and output.

The delay time can be specified in different units, selected with the *UNITS* parameter. Available units are milliseconds, seconds, centimetres and meters. The *DELAY* can be set between 0 and 1000 milliseconds.



To avoid weird and annoying noises in the output signal, the value change made with the *DELAY* potentiometer is not effective until the mouse button is released. At that time audio will be temporarily muted (for a variable time, depending on the delay value used) for the new setting to be effective.

8.2.3.7. OUT LEVEL

Displays parameters and settings related to the output level of the channel:



- **ENABLED:** signal presence indicator (green) at the channel input
- **LEVEL:** when a front panel LEVEL control and/or a GPI port are assigned to the volume control of a channel, the LEVEL window displays in decibels the attenuation applied to the channel output, due to the setting of the LEVEL control and/or GPI port in question, considered as connected "in series". In the above example we see that a global attenuation of 30 dB is applied.
- **MIN and MAX:** lower and upper limits fixed for any LEVEL and/or GPI volume control associated with the channel. In the above example, whether you choose a LEVEL control, a GPI control, or both to control a channel volume, the overall volume range applied to the channel is always between -30 dB and -10 dB.

8.2.3.8. CONFIG

Channel configuration.

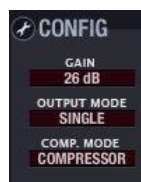

Clicking on the configuration edit icon opens the channel parameter setting window:



- **Amplifier total Gain:** 26 / 32dB
- **Output Mode:** SINGLE / BRIDGE / PARALLEL.
 - In SINGLE mode, a channel is absolutely independent of the other amplifier channels for all settings (input selection, volume, EQ settings, compressor, etc.). In this mode, each channel has its own control window in EclerNet Manager application.
 - In BRIDGE and PARALLEL modes, channels are linked, set and controlled by pair, appearing in software as a unique control panel for each pair of linked channels. Possible pairs are always made of consecutive channels: 1&2, 3&4, 5&6 (4 or 6 channels, depending on the NXA device).
- **Compressor Mode: COMPRESSOR/VPEAK LIMITER (voltage peak limiter).**

It determines how the GUI of the channel compressor will look, with a choice between a classic compressor and a voltage peak limiter for the output signal of the amplifier (see [COMPRESSOR](#) section).

8.2.3.9. Copying and pasting settings between channels

Copy Channel Data and Paste Channel Data icons () , located in the upper right corner of the control panel of each device channel, are used to copy all settings from one amplification channel in temporary memory and paste them in another amplification channel.

Considerations:

- Channel copying and pasting can be done within a single device or from a device channel to a channel of another device
- In the latter case, copying and pasting operation can only be made between channels of the same device series (you cannot copy a channel from an NPA amplifier and paste it into a NXA amplifier, or vice versa)
- To clone the full configuration of all channels from one device to another, use *Copy Device Preset* and *Paste Device Preset* from the icons to the right of the preset name in the upper section of the device configuration

9. EclerNet COMPATIBLE DEVICES: MIMO series digital matrixes

9.1. MIMO88 digital matrix

9.1.1. MIMO88 introduction

The MIMO88 is a digital audio matrix, with 8 inputs and 8 outputs (+ 2 additional monitoring outputs), expandable to 16 inputs/16 outputs by linking a second MIMO88 unit.

MIMO88 programming is done with EclerNet Manager, either via a CAT5 point-to-point connection (directly from computer to MIMO88) or from a remote point of the Ethernet network it is linked to.

Remote management for MIMO88 and in general for any compatible EclerNet device (as NXA, NZA or NPA amplifiers, or DUO-NET PLAYER, MIMO4040CDN, MIMO7272DN, etc.) can be done in the following ways:

- With EclerNet Manager, either via a CAT5 point-to-point connection (directly from computer to MIMO88) or from a point of the Ethernet network it is linked to
- From EclerNet clients of Ethernet Manager or UCP (User Control Panel): several simultaneous web clients, each with its own custom graphic control panel, and EclerNet Manager acting as a web server. EclerNet Manager allows you to create such control panels in a very simple and intuitive manner
- from external “third-party” control devices (Crestron®, AMX®, Extron®, VITY®, Medialon®, RTI®, etc.), using for this the **TP-NET** Ecler communication protocol integrated in MIMO88 (and also in NZA and NPA amplifiers, MIMO88SG, MIMO1212SG, MIMO4040CDN, MIMO7272DN, DUO-NET PLAYER, etc.)

With EclerNet Manager you can configure the MIMO88 for all types of audio processing tasks (DSP or *Digital Signal Processing*) on incoming signals, such as:

- matrix router-mixer with adjustable level for the matrix crossover points, giving a separate mix of different inputs for each output
- mono or stereo channel processing
- level control, mute, vu-meters and phase adjustment for inputs and outputs
- internal signal generator (sine wave, pink noise, white noise, polarity test)
- parametric EQ on inputs and outputs
- “crossover” filters on outputs
- delays on inputs and outputs
- noise gate/compressor on input channels
- limiter on outputs

- input channel priority assignment (*ducking*)
- virtual and physical messaging consoles (*paging*)
- automatic mixer

As control inputs and outputs for hardware devices, the MIMO88 features:

- 8 GPI inputs (*General Purpose Input*), 0 – 10 VDC, connectable to external devices such as contact closures, potentiometers, ECLER WP series panels, 0 - 10 VDC power supply, etc. See [MIMO88 GPIs/GPOs section](#)
- 8 GPO outputs (*General Purpose Outputs*), as NC/NO relays. See [MIMO88 GPIs/GPOs section](#)

GPIO inputs and outputs can be programmed to trigger some functions of the MIMO88, such as:

- recall a *Preset* with an external contact closure
- activate/deactivate a MUTE control with an external physical switch
- set a volume from an external physical control such as a WP Series panel or a potentiometer
- activate a GPO

It is also possible to combine different triggers according to a boolean logic operator to trigger a particular function. Example: if you close a contact connected to GPI1 and a contact connected to GPI2, *Preset#3* is recalled (Boolean operator AND applied to GPI2 and GPI1 inputs).

Similarly, GPO outputs can be programmed to react to certain triggers and may thus control external devices such as light indicators, audio/video players, lights, motors, electrical circuits, etc.

For more information about GPIs and GPOs, see [MIMO88 EVENTS section](#) which also includes the management of events triggering based on a calendar.

Additionally, MIMO88's rear panel provides two connectors for Ecler digital control bus (ER-Bus): REMOTE 1 and REMOTE 2. This control bus is compatible with Ecler digital devices for remote control such as:

- WPTOUCH: programmable digital touch panel (to select sound sources or *Presets* and adjust volume and MUTE)
- eMPAGE or MPAGE16: digital touch console for real time voice messaging or "paging"

See [MIMO88 PAGERS/DUCKERS](#), [MIMO88 REMOTES section](#) and [MIMO88 EVENTS section](#).

For more information about MIMO88's hardware, refer to the product manual.

9.1.2. 8x8 and 16x16 setups

Individually, a MIMO88 unit is a 8x8 audio matrix, i.e. with 8 inputs and 8 outputs. In a configuration with two MIMO88s connected by LINK BUS in MASTER-SLAVE mode, the couple is behaving for all purposes as a single matrix with 16 inputs and 16 outputs. In that case it is important to note the following points:

- The hardware MASTER / SLAVE switch of the back panel must be set before powering on, one unit set in MASTER position and the other in SLAVE position
- For software settings with EclerNet Manager, you have to configure the MASTER unit in 16x16 mode. See [MIMO88 general section](#)
- The physical link between the two units is a CAT5 crossover cable (**IMPORTANT: this linking CAT5 cable must be a crossed cable**), point-to-point (i.e. directly between LINK BUS ports of both units and without any type of intermediate hardware, such as Ethernet switches or routers, etc.) and with a maximum length of 100 meters. This link connects the two units for all purposes: digital audio and control signals
- It is important to select the 16x16 operating mode from the start of the configuration tasks of a new EclerNet Project. Such adjustment shall be made from the CONFIG section of the [MASTER MIMO88 detailed view](#). Configuration changes when switching from 16x16 to 8x8 mode or vice versa can lead to the loss of any settings made for system programming.
- All programming and remote control of the couple is done from EclerNet Manager on the MASTER unit, showing all functions of the resulting 16x16 matrix (16 inputs, 16 outputs, 16x16 matrix, 16 paging zones, etc.).
- The SLAVE unit doesn't need not be included as a device in the Project, nor to be connected to the network via its Ethernet port since it is totally controlled by the link to your MASTER unit
- If you connect both units (MASTER and SLAVE) to the network, the application will detect and display them in the *Project Explorer Helper (Online and Unused Devices)* as "MIMO88" and "MIMO88 (slave)", respectively MASTER and SLAVE.



MASTER and SLAVE MIMO88 units are automatically detected

- A unit configured as SLAVE and included in the Project as an additional device has a detailed view named MIMO SLAVE, showing a very reduced control panel (see picture). You can however be connected to it, for example to remotely update its *firmware* or to change its network parameters

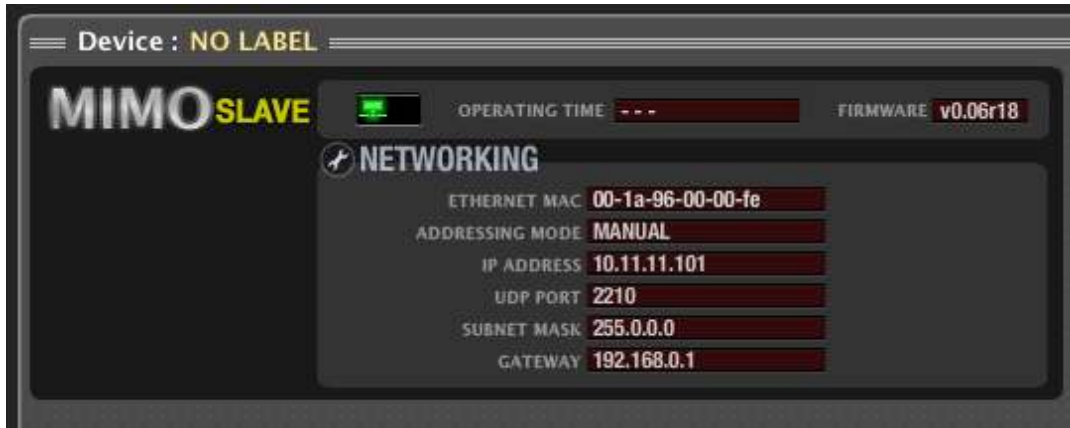

- If a Project has several MASTER-SLAVE couples, the only way for EclerNet Manager to manage each pair is the LINK BUS port of the physical connection between the two units. In other words, the application doesn't know which SLAVE unit is the counterpart for each MASTER unit. It is the user's task to identify them by editing their names and comments, making them useful for the "Device Finder" tool (activating a MIMO88 unit makes its front panel LEDs flashing until deactivation).

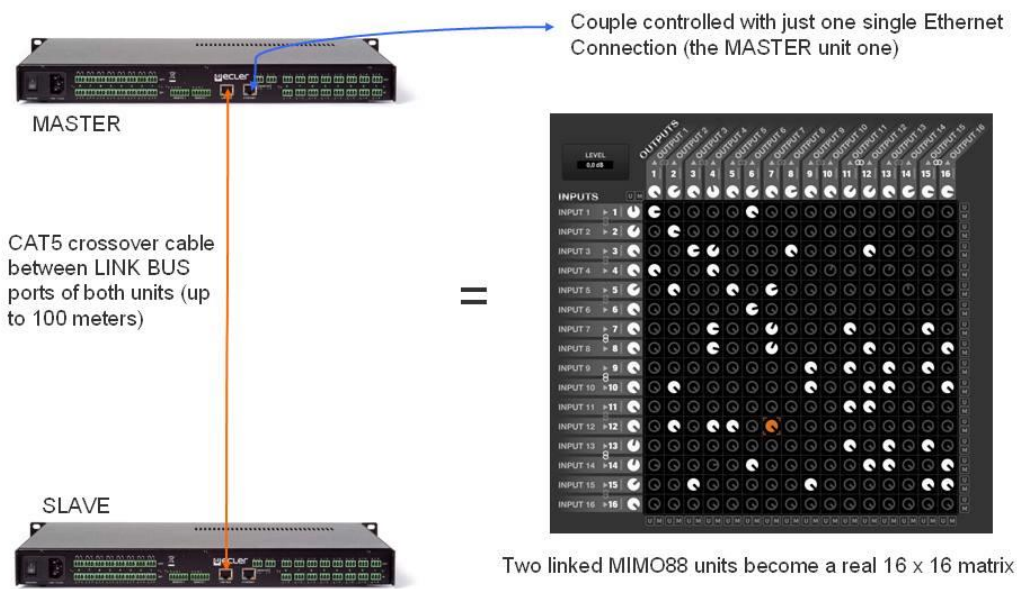

"LINK" LED indicators on the MIMO88's front panel have different behaviours, depending on whether the unit operates in 8x8, 16x16 MASTER or 16x16 SLAVE mode and on its status:

- 8x8 MASTER mode: LED off
- 16x16 MASTER mode:
 - Fast flashing green LED: correct MASTER-SLAVE connection, error-free communication
 - Fast flashing LED, alternating between green and red: communication error in the MASTER-SLAVE connection
 - Slow flashing LED, alternating between green and red: no BUS LINK-connected SLAVE is detected or it's another MASTER unit
- 16x16 SLAVE mode:
 - Fast flashing orange LED: correct MASTER-SLAVE connection, error-free communication
 - Fast flashing LED, alternating between orange and red: communication error in the MASTER-SLAVE connection
 - Slow flashing LED, alternating between orange and red: no BUS LINK-connected MASTER is detected or it's another SLAVE unit

If MASTER-SLAVE connection is invalid, a broken link symbol appears (green and red flashing rectangles ) in EclerNet Manager, in the MASTER device status window. Possible causes are:









- no device connected to the BUS LINK of the MASTER unit
- connected equipment is another MASTER unit (its rear panel switch is in MASTER position instead of SLAVE)



9.1.3. MIMO88 device detailed view

The detailed view of a MIMO88 device has the following appearance:

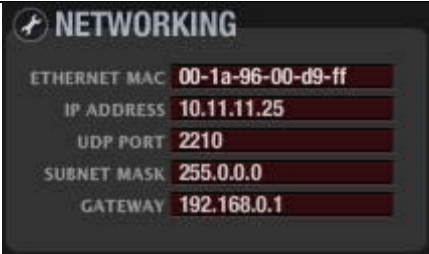

There are two distinct parts. A top section intended for unit general configuration and settings, and a series of tabs at the bottom (INPUTS, MATRIX, OUTPUTS, etc.) to show the different sections of the device programming.

	Device model and name 
	Status monitoring and alarms window. See Table of status monitoring and alarm icons 9.4. Table of status monitoring and alarm icons
	Active Preset window: indicates the Preset (configuration memory) currently active in the device
	Presets management icons: <ul style="list-style-type: none"> • Save Device Preset (saves the current Preset). See (1). • Copy Device Preset (copies the current Preset). • Paste Device Preset (pastes the previously copied Preset). Pasting can be made in another Preset of the same unit or another MIMO88 unit of the Project.
	Unit's firmware version
	Signal selector for the MIMO88 headphone output: any one of the 8 inputs or outputs of a MIMO88 unit (8x8 mode) or 16 inputs or outputs of a MASTER-SLAVE couple (16x16 mode) or NONE. The signal selected by this selector will be sent simultaneously to the front MONITOR output (unbalanced 3.5 mm jack and volume adjustment) and rear MONITOR 1 and 2 (balanced Euroblock connector). Note: you can use the monitor output as an additional auxiliary send of the audio matrix
	Internal signal generator offering pink noise, white noise, sine wave and polarity check, with frequency adjustable between 10 and 20,000 Hz and level=0 dBV

	<p>Reports on the configuration of the device, operating hours accumulated and time and date of the internal clock of the MIMO88 unit.</p> <p>To access the device configuration, click on the spanner icon. See (2)</p>
	<p>Reports on the configuration of the device network parameters.</p> <p>To access the configuration of the device network parameters, click on the spanner icon. See (3)</p>
	<p>Edition of carousel lists (see Carousel lists for MIMO88 section)</p>
	<p>Event Management (see MIMO88 EVENTS section)</p>

9.1.4. MIMO88 general section

The top section of the MIMO88 detailed window provides the following items:



(1) Save Device Preset (saves the current Preset).

Left-clicking this icon opens a window with the following options:



- Name of the Preset to save at the selected location (location number can't be changed)
- Data saved in the Preset: Inputs section, Outputs section, Matrix section, Pagers section (Pagers/Duckers), Event/Remote Enables, and finally Link Groups within the matrix.

The Preset stores data selected in the previous window only, so that recalling the Preset only changes (rewrite) data stored in this Preset, not affecting other parameters of the MIMO88.

This ability to save "partial" Presets allows a great freedom of management. Example: two Presets include MATRIX data only, with two different setups for inputs/outputs routings. By loading either of these two Presets during system operation, only such routing will change, respecting inputs and outputs settings the user made up to that point (volume, EQ, etc..), since data for INPUTS and OUTPUTS sections were not saved in any of the two Presets.

Right-clicking this icon opens a window with the following options:

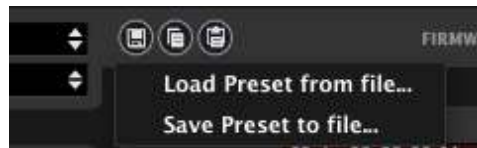

- **Load Preset from file:** lets you load a Preset stored on a hard drive, external USB memory, etc.
- **Save Preset from file:** lets you save a Preset on a hard drive, external USB memory, etc.

These two functions are very useful for copying in a MIMO88 unit a Preset coming from another unit currently offline, or from another Project or facility. Preset files are saved on disk with a ".MIMO_preset" suffix.

Emergency preset– undo preset:

There are two special Presets among the 99 available Presets for MIMO88: Presets #98 and #99:

- **Preset #98** is what we might name an “Emergency Preset” (the save file could be renamed Emergency, if desired). When you call this Preset for recovery, the existing configuration is saved beforehand in the preset #99, or “UNDO Preset”. Then Preset #98 is recalled. If you later recall Preset #99 (UNDO), MIMO88 recovers the exact settings it had before loading Preset #98.

Application example: let's imagine an emergency scenario, requiring to spread an evacuation message in all areas of a facility. In such a scenario, when a trigger (a contact closure that comes from the central fire panel, for example) appears, Preset #98 is recalled so that, when loaded, MIMO88 mutes all sound sources, except the evacuation message, and adjusts destinations and output volumes for the message to be delivered with the required intelligibility. The sequence would be:

1. The system is operating normally
2. The central fire panel closes a contact that is connected to a MIMO88's GPI
3. This contact triggers an event recalling Preset #98 (EMERGENCY):
 - the current configuration is saved in Preset #99 (UNDO)
 - Preset # 98 (EMERGENCY) is recalled
4. When the contact is opened (end of emergency), manually or by another event with an inverted polarity on the same GPI input, Preset #99 (UNDO) is recalled, returning the system to its initial state as before the onset of the emergency scenario (point 1)

Note: Preset #99 (UNDO) remains available in the Presets list only as long Preset #98 (EMERGENCY) is enabled.

(2) Device configuration.

Clicking on the configuration edit icon opens the following parameter setting window:



- **Mode:** 8x8 or 16x16 operating mode (if you select the latter option, this unit is designated as MASTER of the MASTER-SLAVE couple, and the second unit must be connected as SLAVE by LINK BUS, with its back panel switch in SLAVE position)
- **Preset 1 Start Up:** when this box is checked, the M88 unit loads Preset #1 whenever initialized, that is, every time you turn it off then on again. Otherwise, the M88 will start with the last configuration, controls and parameters values before shutdown.
- **Local Date / Local Time:** date and time given by MIMO88's internal clock. Clicking on the circular icon located on its right synchronizes this unit's clock with Windows clock, after requesting confirmation



(3) Network parameters configuration.

Exactly the same window and same parameters than those available with the Network Configuration option from the device context menu:



It's important to note that EclerNet compatible devices (MIMO88, NZA, NPA, MIMO88SG, MIMO1212SG, MIMO4040DN, DUO-NET PLAYER, etc.) **do not support dynamic allocation protocol for network addresses, or DHCP**, ie: they can't dynamically negotiate IP addresses and require manually configured and fixed IP addresses. It is highly recommended that both EclerNet devices (MIMO88, NZA, NPA, MIMO88SG, MIMO1212SG, MIMO4040DN, DUO-NET PLAYER, etc.) and the computer running EclerNet Manager are configured with static network address within the same range, for full connectivity between all of them. An example of a small local network of this type may have the following network settings in its EclerNet devices:

DEVICE	IP ADDRESS	IP SUBNET MASK
MIMO88 (first floor)	10.5.5. 10	255.255.255.0
MIMO88 (second floor)	10.5.5. 11	255.255.255.0
MIMO88 (outdoor areas)	10.5.5. 12	255.255.255.0
NZA6-180 (first floor)	10.5.5. 20	255.255.255.0
NZA6-80 (second floor)	10.5.5. 21	255.255.255.0
NZA4-700 (outdoor areas)	10.5.5. 22	255.255.255.0
PC (running EclerNet Manager)	10.5.5. 100	255.255.255.0

Up to 255 devices, each with a different IP address (in the range of 10.5.5.1 to 10.5.5.**255**), could be part of this example network.

If you want to know your local network TCP / IP configuration, a simple method is to open the Command Console (Start-> Run-> CMD) and to run the `ipconfig /all` command. More information with the following link:

<http://www.microsoft.com/resources/documentation/windows/xp/all/proddocs/en-us/ipconfig.mspx?mfr=true>

Note: despite not supporting DHCP, EclerNet devices (and generally any device with static IP) can coexist with dynamic IP devices, as a DHCP server usually reserves a part of the addresses range for dynamic allocation and another part for static allocation.

9.1.5. MIMO88 INPUTS section

The INPUTS section of a MIMO88 device has the following appearance:



At the top left of the section there is a list of unit inputs, showing from 8 inputs (8x8 configuration, all channels in mono) to 16 inputs (16x16 configuration, all channels in mono) to all possible combinations of pairs of stereo channels with mono channels.

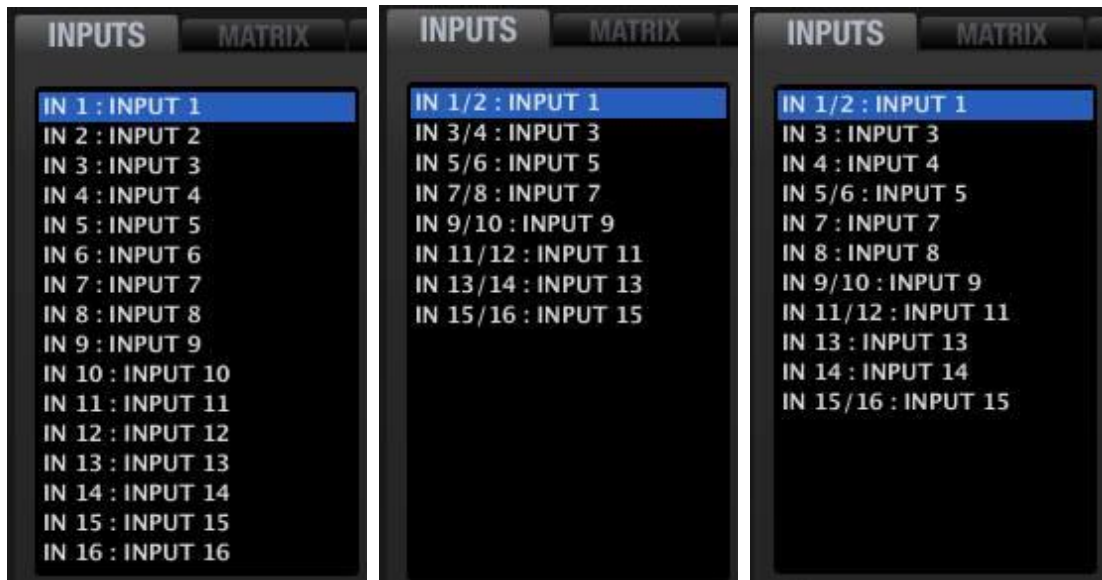

Examples with all inputs in mono, all inputs in stereo and a combination of mono and stereo inputs

When one of them is selected with the mouse (left button), it turns blue and is selected for the parameters' adjustment (EQ, GAIN, DELAY, GATE, etc.). With the context menu of one of the list inputs (right mouse button) you can rename it, edit its comment field, etc. The input number displayed by default is not editable.

In the upper right corner of the INPUTS window, there are two icons named "Copy Channel Data" and "Paste Channel Data".

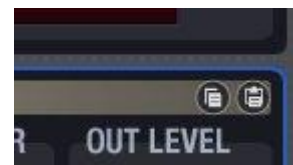

Clicking "Copy Channel Data" in a channel (source channel) stores all parameters in a temporary memory.

Clicking "Paste Channel Data" in a channel copies in the destination channel the parameters stored temporarily during the last "Copy Channel Data" operation, configuring the destination channel as the source channel.

INPUTS section is composed of different groups of controls and indicators: INPUT, DELAY, PARAMETRIC EQ, GATE, COMPRESSOR, and LEVEL. The order of signal processing matches the graphic layout of the screen: INPUT -> DELAY -> PARAMETRIC EQ -> GATE -> COMPRESSOR -> LEVEL

9.1.5.1. INPUT

- **SELECT:** allows you to select this channel input amongst available sound sources:
- **NONE:** no input (muted channel input)
- **GEN:** internal generator signal, controlled from the GENERATOR panel
- **INx:** where x is the numbering of one of the MIMO88's physical inputs (1 to 8 for inputs 1 to 8 linked to a MASTER unit and 9 to 16 for inputs 1 to 8 linked to a SLAVE unit.) Selecting this input type enables the sensitivity selector, with the selected option marked in green, as well as PHANTOM and GAIN settings:
 - **Sensitivity:**
 - **0 dB:** LINE level signals
 - **-20 dB:** LOW LINE level signals, as delivered by MP3 players, iPod®, laptops, etc..
 - **-40 dB:** MIC level signals
- **GAIN:** ±10 dB adjustment of the incoming signal gain
- **PHANTOM:** toggles the remote DC power supply for the condenser microphones connected to this physical input
- **MODE:** MONO or STEREO. Selecting the STEREO mode associates this input to its counterpart (normal input pairs are 1 & 2, 3 & 4, 5 & 6, 7 & 8, 9 & 10, 11 & 12, 13 & 14 or 15 & 16) as a stereo input displayed as a single input (IN 1 / 2 or IN 3 / 4, etc.) in the input list and in the *Project Explorer* window), processing settings being equally applied to both inputs.



When two inputs are linked as a stereo pair, they use the odd input settings effective before linking. If you split them again, each input returns to the settings it had before linking. In the MATRIX section, a stereo input is represented by the stereo link symbol (bound rings) between the two inputs constituting the normal pair:



9.1.5.2. DELAY

The DELAY section lets adjust an independent time delay for each input channel.

The delay time can be specified in different units, which are determined by the UNITS selector (up and down arrows to the right of the text box).

Available units are milliseconds, seconds, centimetres and meters. DELAY can be set between 0 and 1000 milliseconds.



To avoid weird and annoying noises in the output signal, the value change made with the DELAY potentiometer is not effective until the mouse button is released. At that time audio will be temporarily muted (for a variable time, depending on the delay value used) for the new setting to be effective.

9.1.5.3. PARAMETRIC EQ

This section groups the four parametric filters available per input channel, very useful to correct the frequency response.

Available parameters are described below. After selecting one of the 4 filters (its numerical indicator has a white fill, as filter 1 in the image), its parameters are displayed and their setting is enabled:

- **ENABLE/DISABLE:** enables/disables the parametric EQ, affecting all filters from this section. When the value is DISABLE (top left button greyed out), there is no filter processing (equivalent to BYPASS filters). In the opposite case (green button), EQ is enabled, and its operation depends on the rest of the parameters in this section
- **FILTER TYPE:** type of filter used. You can select one of the following filter types (adjustable controls for each filter type are shown between brackets):
 - **Bypass:** filter not used. Bypassed filters have a grey circle around their numbers (filter #2 or 4 in the picture), while operating filters (not in bypass mode) have a white circle (filter #1 or 3 in the picture)
 - **Parametric EQ (FREQUENCY, GAIN, Q):** classic parametric equalizer filter with adjustable central frequency (between 20 Hz and 20 kHz), gain or attenuation at central frequency (between +12 dB and -60 dB) and bandwidth (1/Q, Q between 0.3 and 200).
 - **Low-Shelf and High-Shelf with a 6 or 12 dB/oct slope (FREQUENCY, GAIN):** shelving type filters with adjustable cut-off frequency (between 20 Hz and 20 kHz) and gain or attenuation (between +12 dB and -60 dB).

- **Low-Pass y High-Pass with a 6 or 12 dB/oct slope (FREQUENCY):** these are low-pass and high-pass filters with adjustable cut-off frequency (between 20 Hz and 20 kHz).
- **All-Pass order 1 and 2 (FREQUENCY in both, Q in order 2 only):** all-pass filters that do not affect the signal amplitude, but the phase at certain frequencies (in contrast with delay, which changes phase at all frequencies). The main application of this type of filter is usually to compensate phase errors in speakers or phase shifts introduced by crossover filters



The white outer ring indicates that the filter is enabled. The white fill indicates the selected filter.

9.1.5.4. GATE

Noise gate section applied to the input signal, affecting its dynamic behaviour. It is very useful to reduce or eliminate background noise picked up by a microphone or existing in a recording, distinguishing between background noise and valid audio signal:

- When the input signal is below the detection threshold, the gate is "closed" or, which is the same, applies some attenuation to the signal (determined by the DEPTH setting in dB)
- When the input signal exceeds the detection threshold, attenuation stops, leaving the gate "open. " The transition time to this state is determined by the ATTACK parameter
- When the input signal falls below the detection threshold, the gate stays open without attenuation the amount of time determined by the HOLD parameter and finally closes, returning to the attenuation level set (the amount of time for this is set by the RELEASE parameter)



Available settings are:

- **ENABLE/DISABLE:** enables/disables the Noise Gate (green button/grey button). When in DISABLE mode, the rest of the section controls are disabled.
- **THRESHOLD:** detection threshold. Defines the input signal level below which the signal is attenuated with an amount indicated by DEPTH (closed gate). This parameter ranges from +18 dB to –80 dB.
- **DEPTH:** attenuation applied to the signal when it is below the detection threshold (closed gate). This parameter ranges from 0 dB to +80 dB.
- **ATTACK:** attack time. Determines the amount of time between the passing of the threshold and the cancellation of the attenuation applied to the input signal (open gate). Adjustment range from 0.1 ms to 500 ms
- **HOLD:** amount of time the gate stays open (without attenuation) once the signal falls back below the detection threshold. Adjustment range from 10 ms to 3 s
- **RELEASE:** release time. Determines the time it takes to close the gate again after the hold time. In this case, the range covers from 1 ms to 1 s.

A correct setting of the noise gate ATTACK, RELEASE and HOLD times is fundamental, for example to get a clear and intelligible voice signal from a speech made in a noisy environment.

9.1.5.5. COMPRESSOR

The compressor section offers a processing of the input signal dynamic behaviour, allowing you to modify the level differences between high- and low-level passages of the signal, thereby obtaining a resultant signal with a controlled dynamic margin. Available settings are:

- **ENABLE/DISABLE:** enables/disables the compressor (green button/grey button). When in DISABLE mode, the rest of the section controls are disabled.
- **THRESHOLD:** compression threshold. Specifies the input signal level at which compression begins to occur. This parameter ranges from +18 dB to -36 dB.
- **RATIO:** compression ratio. This parameter specifies how much the compressor reduces the level of an input signal exceeding the compression threshold. With a 1:1 value, the signal level remains unchanged, while with the extreme value of inf: 1, the compressor performs as a signal limiter, preventing the input signal to exceed the level defined by the compression threshold
- **GR (Gain Reduction):** VU meter-like indicator of the compression applied to the signal, displaying in decibels the reduction of the compressor output signal compared to the input signal
- **KNEE:** bend of the compression curve. Allows you to select a progressive (SOFT) or sharp (HARD) compressor response when the signal level is near the compression threshold, i.e. to let the transients pass through or not before the compressor starts operating
- **ATTACK:** attack time. Determines the time the compressor takes to respond when the input level rises above the threshold. The range covers from 0.1 ms to 500 ms
- **RELEASE:** determines how quickly the compressor stops acting once the signal input level falls back below the threshold. In this case, the range covers from 10 ms to 1 s.
- **MAKE-UP:** Additional gain for the signal after compression, from 0 to +10 dB. The audible effect of compression is usually a more uniform signal but a lower average intensity (volume). The additional MAKE-UP gain allows you to increase the average level or volume of the signal after it has been compressed, recovering presence and intensity



Correctly setting compressors' ATTACK and RELEASE times is not an easy task: too short release or attack times result in excessive and perceptible low frequencies distortion; on the other hand, too long times could make a compressor useless since it would act too late, letting high intensity signal peaks pass through without applying any compression.

9.1.5.6. LEVEL

Adjusts the overall level of the input channel that will be sent to the matrix, after pre-processing (EQ, DELAY, GATE, etc.)

- **VOLUME:** channel volume, adjustable between $-\infty$ and 0 dB. There are two Vu meter-type level indicators to the right of the channel fader: the left bar displays the input signal level and the right one the channel output signal level after processing. Above the bar, the saturation indicator (CLIP) lights up when the input signal (before processing by EQ, compressor, etc..) exceeds the saturation level (+18 dBV)
- **MUTE:** MUTE: mutes audio for this channel.
- **POLARITY:** allows the input signal phase to be inverted (180 degrees shift).



9.1.5.7. FREQUENCY SHIFTER

Each input has a FREQUENCY SHIFTER (bottom right corner), an efficient system to reduce the risk of feedback loops (audio feedback or Larsen effect) when a microphone source is near the speaker(s) producing its signal, once amplified. When activated, this function slightly shifts the incoming signal frequency on the affected channel before sending it to the matrix mixer and then to the selected output. The shift is so slight that it is barely noticeable to the listener, especially when it occurs in the frequency range of the human voice. A few cycles (Hz) displacement is enough to greatly increase the system protection against possible feedbacks.



9.1.6. MIMO88 MATRIX section (I/O matrix)

The MATRIX section of a MIMO88 device has the following appearance:

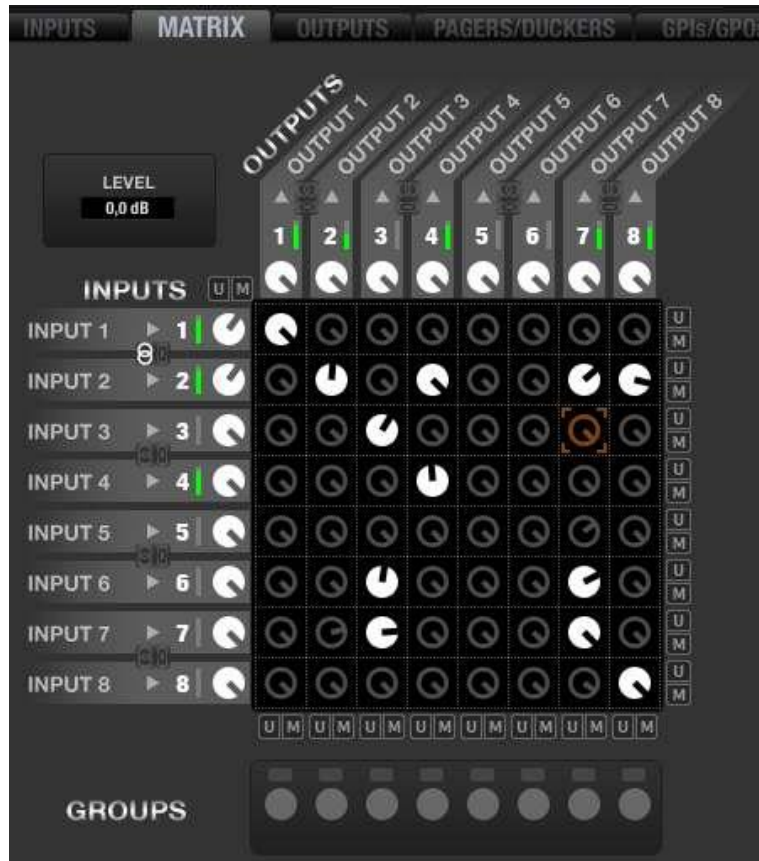

The matrix inputs are represented in INPUTS column, on the left, while the outputs are arranged in OUTPUTS row, at the top.

In the central area there are controls for the crossing points (or "patches") between inputs and outputs, allowing to configure a custom mix of the desired inputs for each output, with individual level adjustment of each input in the mix. The input mix of for an output is independent of the other mixes (other outputs).

The LEVEL field located in the upper left corner displays the value of the knob selected with the mouse (orange in the matrix), and can be modified with the mouse from the knob itself (click and hold then drag) or from the LEVEL field using the computer keyboard (numerical value + ENTER).

9.1.6.1. INPUTS column

INPUTS column shows the device inputs (8 or 16 depending on the selected operating mode – 8x8 or 16x16). Next to the name of each input, there is a small VU meter and a level adjustment knob. The VU meter is a "pre-fader"-type, i.e. it displays the level of the signal taken before the level knob, matching the left bar of the VU meter for the same channel in the INPUTS section. The triangular-shaped indicator to the left of the input number matches the CLIP indicator in the left bar of the VU meter for the same channel in the INPUTS section.

The level adjustment knob is in fact the same LEVEL control that the channel fader within the INPUTS section. Changing one of them (MATRIX knob or INPUTS fader) changes the other at the same time as they are in fact distinct graphical representations of the same control: the amount of input signal that is sent to the matrix row to which it belongs.

Clicking on a knob with the left mouse button and holding it allows you to adjust the knob setting or amount of signal sent to the matrix row.

A double-click on a knob toggles the mute function of this send or "patch". The knob is filled in grey when MUTE is active and in white when it is not. This setting is exactly the same as the one from the INPUTS section (LEVEL: MUTE button)

Clicking on the **STEREO** symbol (two bound rings) between two naturally linked inputs (one odd input and the next one constituting the pair: 1&2, 3&4, 5&6, etc.) lets link them in stereo mode (symbol highlighted in white) or break the link, for mono mode (grey symbol). This setting is exactly the same as the one from the INPUTS section (LEVEL: MODE: MONO or STEREO).



Stereo linking of two inputs copies the odd channel status in the even channel of the pair, and from that moment all adjustments (level, mute, equalization, etc.) are simultaneously applied to both.

If **Link channels** mode is enabled (chain link symbol) in addition to stereo mode, levels and mute function of the 2 crossing points between these inputs and outputs are synchronized.

Examples:

- Input 1 stereo, Output 1 stereo, both Link Channels controls enabled (the two crossing points are synchronized and always share the same values):

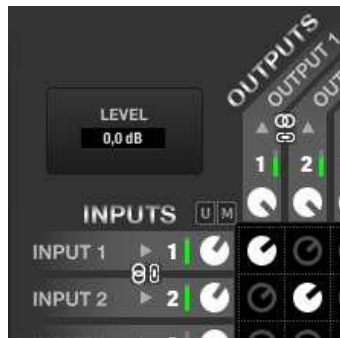

- Input 1 stereo, Output 1 stereo, both Link Channels controls disabled (the two crossing points are not synchronized and can have different values):

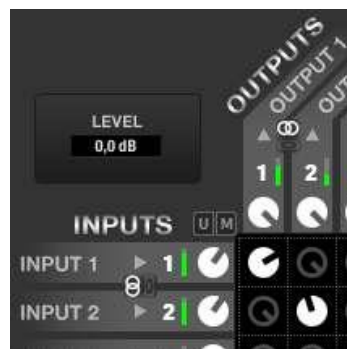

9.1.6.2. INPUTS-OUTPUTS crossing points

The central square area, a table of 8 rows x 8 columns of *knobs* (8x8 Mode) or 16 rows x 16 columns of *knobs* (16x16 Mode), lets route inputs to outputs and set their levels.

Any input or combination of inputs can be sent to any output, with a custom level independent from other sends. So, to send multiple inputs to one output, that output receives a mix of the selected inputs, each one with the desired level, independent from the other levels of the matrix.

To patch an input to an output, you need to activate their crossing point by double-clicking on the *knob* located at the intersection line between inputs column and outputs row. A *knob* is filled in white when its crossover point is turned on, and filled in grey when turned off (or in MUTE status.).

By left-clicking on a crossing point *knob* and holding the mouse button, we can adjust the *knob* setting or amount of input signal sent to the output determined by this crossing point. The *knob* setting can be changed whether the crossover point is active or not. The *knob* setting and the MUTE function are always individual, affecting only the selected *knob* (coloured in orange) even if the source and/or destination stereo is stereo.

Additionally, there are some buttons marked as "U " (UNMUTE) and "M " (MUTE) in various locations of the matrix:

- At the top left of the matrix: they simultaneously act on all crossing points of the matrix (the 8x8 or 16x16 *knobs* it contains), activating or deactivating all sends from all inputs to all outputs
- Under each column of the matrix: they simultaneously act on all crossing points of the column (the 8 or 16 *knobs* it contains), activating or deactivating all sends from all inputs to this output
- To the right of each matrix row: they simultaneously act on all crossing points of the row (the 8 or 16 *knobs* it contains), activating or deactivating all sends from this input to all outputs

9.1.6.3. OUTPUTS row

OUTPUTS row shows the device outputs (8 or 16 depending on the selected operating mode – 8x8 or 16x16). Next to the name of each output, there is a level adjustment knob and a small VU meter. The VU meter is a "post-fader"-type, i.e. it displays the level of the signal taken after the level knob, matching the right bar of the VU meter for the same channel in the OUTPUTS section. The triangular-shaped indicator above the channel number matches the CLIP indicator in the right bar of the VU meter for the same channel in the OUTPUTS section.

The level adjustment knob is in fact the same LEVEL control that the channel fader within the OUTPUTS section. Changing one of them (MATRIX knob or OUTPUTS fader) changes the other at the same time as they are in fact distinct graphical representations of the same control: the amount of output signal for the mix determined by the crossing points in this output column. This is MASTER control of this output signal, which is then processed by the settings made in OUTPUTS section.

Clicking on a knob with the left mouse button and holding it allows you to adjust the knob setting or amount of output signal.

A double-click on a knob toggles the MUTE function for this output. The knob is filled in grey when MUTE is active and in white when it is not. This setting is exactly the same as the one from the OUTPUTS section (LEVEL: MUTE button)

Clicking on the **STEREO** symbol (two bound rings) between two naturally linked outputs (one odd output and the next one constituting the pair: 1&2, 3&4, 5&6, etc.) lets link them in stereo mode (symbol highlighted in white) or break the link, for mono mode (grey symbol). This setting is exactly the same as the one from the INPUTS section (LEVEL: MODE: MONO or STEREO).

Stereo linking of two outputs copies the odd channel status in the even channel of the pair, and from that moment all adjustments (level, equalization, etc.) are simultaneously applied to both.

If **Link channels** mode is enabled (chain link symbol) in addition to stereo mode, levels and mute function of the 2 crossing points between these inputs and outputs are synchronized (see examples in [INPUTS column](#)).



9.1.6.4. Matrix Link Groups

Matrix Link Groups are a tool to group and synchronize matrix controls, so that operating one of them simultaneously operates all elements belonging to the same group.

Within a group there may be knobs for inputs, outputs, matrix crossing points or a mix of them.

To create or edit a group, you must click on a selection button in order to light it up in green, as for Group 2 in this image:



Then the control to select the group type will flash, indicating that the group is in edit mode, enabling the following actions:

1. Selecting the group type (right mouse button):



- **Mute Group:** operating one of the included controls mutes or unmutes simultaneously all of them, maintaining independent level adjustments
- **Volume Group:** included controls always share the same level. Changing one of them has exactly the same effect on all group members, maintaining independent ON/OFF mute status
- **Mute & Volume Group:** level value ON/OFF mute status are both common to all elements of the group

- **Parallel Output Group:** columns belonging to one of these groups behave exactly the same for the routing of the input signals they receive (enabled/disabled crossing points, levels, mute ON or OFF, selection of sources from the carousel lists). This option is ideal when you need to combine individual rooms into a larger one, so that dedicated outputs always share the same audio content, and you have to control only one of them to control all rooms. Output parameters (level, EQ, compressor for each output, OUT1, OUT2, and so on) of affected columns are still available for free individual settings (same content but different output levels and equalization if necessary)

2. Selecting the group members: click on the knobs you want to include in the group being edited.

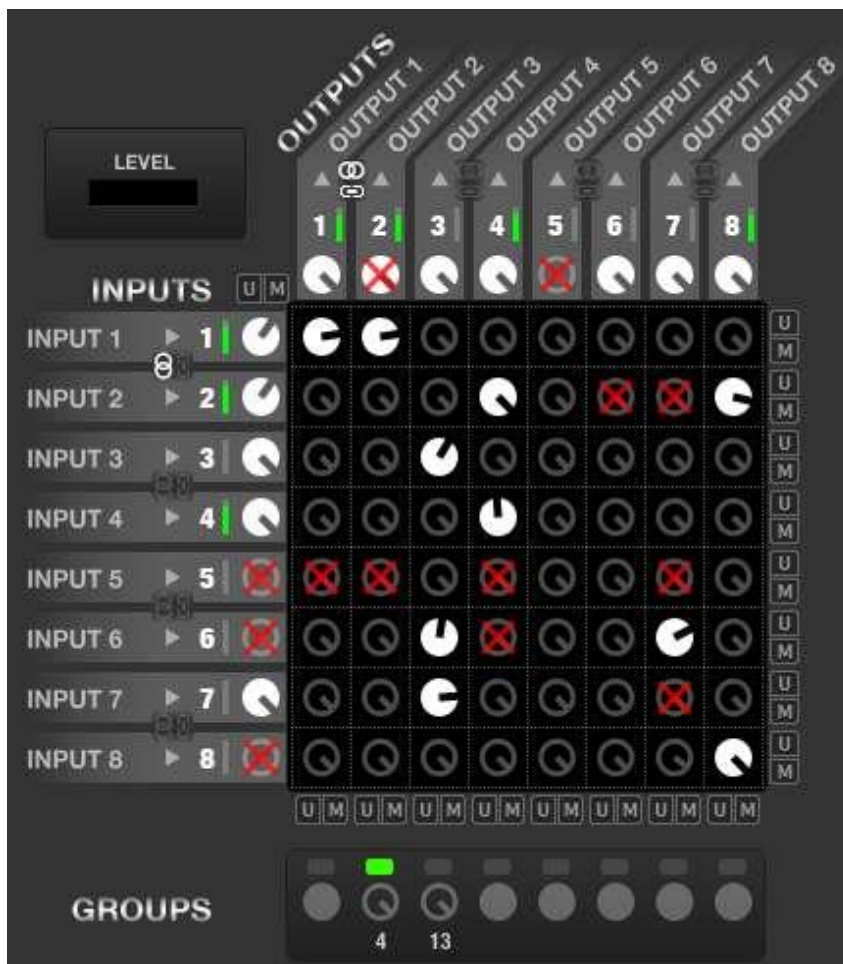

Whenever a member is added to the group, the new member and the other members of the group blink.

Members that can't be included in the group because they belong to another one are displayed with a red cross superimposed.

Complete the group editing by pressing again your selection button (turns from green to grey shading again).

Once a group is created, any remote-control method applied on one of its elements will affect the entire group. For example, if one of the knobs of a Volume Group is assigned to a GPI (external potentiometer), a WPTOUCH control or a UCP virtual fader for remote management, operating one of these remote controls affects not only this knob but also, and simultaneously, all the knobs of the group (moving a single hardware potentiometer can change several volumes at a time in the matrix).

The restrictions of the groups are:

- Maximum of 8 simultaneous groups
- Maximum of 16 elements in each group (the counter under a group indicates the number of group members (4 and 13 for groups 2 and 3 in the example shown above))
- A single element cannot belong to multiple groups

However, you can save groups configuration when saving a Preset (Link groups check box checked) so that different Presets have different link groups, multiplying the possibilities of control grouping.

9.1.7. MIMO88 OUTPUTS section

The OUTPUTS section of a MIMO88 device has the following appearance:

OUT 1 : OUTPUT 1
 OUT 2 : OUTPUT 2
 OUT 3 : OUTPUT 3
 OUT 4 : OUTPUT 4
 OUT 5 : OUTPUT 5
 OUT 6 : OUTPUT 6
 OUT 7 : OUTPUT 7
 OUT 8 : OUTPUT 8

LEVEL

S M CLIP

-28,0 dB

MODE **MONO**

CROSSOVER

LOW-PASS

TYPE **Bypass**

600 2k 5k 10k 20k

FREQUENCY

HIGH-PASS

TYPE **Bypass**

600 2k 5k 10k 20k

FREQUENCY

PARAMETRIC EQ

① ② ③ ④ ⑤ ⑥ ⑦ ⑧

TYPE

600 2k 5k 10k 20k

FREQUENCY

MIN GAIN MAX

MIN Q MAX

DELAY

MIN MAX

0,00 ms

LIMITER

GR

-18 0 +9

-27 +18

-36

THRESHOLD

MIN MAX

ATTACK

MIN MAX

RELEASE

At the top left of the section there is a list of unit outputs, showing from 8 outputs (8x8 configuration, all channels in mono) to 16 outputs (16x16 configuration, all channels in mono) to all possible combinations of pairs of stereo channels with mono channels.

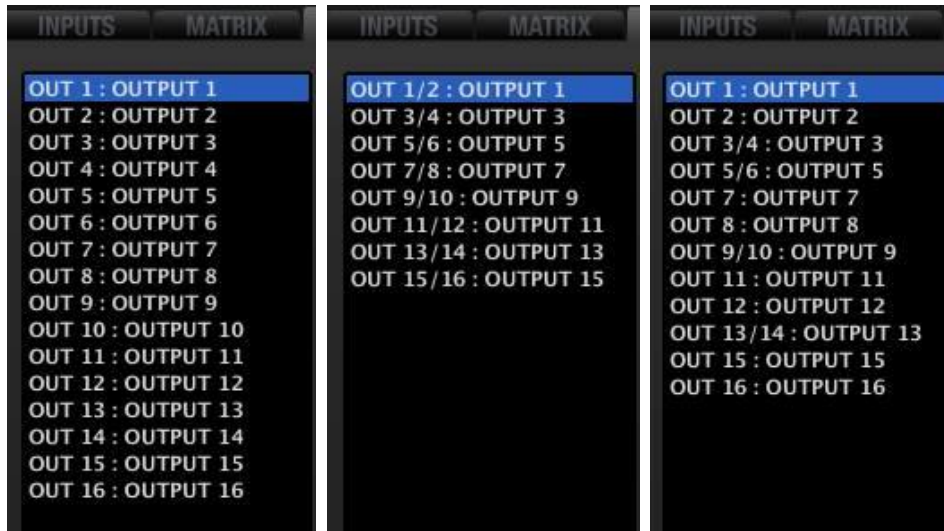

Examples with all outputs in mono, all outputs in stereo and a combination of mono and stereo outputs

When one of them is selected with the mouse (left button), it turns blue and is selected for the parameters adjustment (LEVEL, CROSSOVER, EQ, DELAY, LIMITER). With the context menu of one of the list outputs (right mouse button) you can rename it, edit its comment field, etc. The output number displayed by default is not editable.

OUTPUTS section is composed of different groups of controls and indicators: LEVEL, CROSSOVER, PARAMETRIC EQ, DELAY, LIMITER being the processing order applied to the output signals.

In the upper right corner of the OUTPUTS window, there are two icons named “Copy Channel Data” and “Paste Channel Data”.

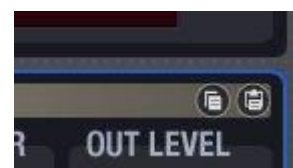

Clicking on “Copy Channel Data” in a channel (source channel) stores all parameters in a temporary memory.

Clicking on “Paste Channel Data” in a channel copies in the destination channel the parameters stored temporarily during the last “Copy Channel Data” operation, configuring the destination channel as the source channel.

9.1.7.1. LEVEL

Adjusts the overall channel output level after processing (CROSSOVER, PARAMETRIC EQ, DELAY, LIMITER):

- **VOLUME fader:** output channel volume, adjustable between $-\infty$ and 0 dB. There are two Vu meter-type level indicators to the right of the channel fader: the left bar displays the output channel signal level coming from the matrix and the right one the output channel signal level after processing (LEVEL, CROSSOVER, EQ, etc.). Above the bar, the saturation indicator (CLIP) lights up when the input signal (before processing by EQ, compressor, etc..) exceeds the saturation level (+18 dBV)
- **SOLO:** mutes all device channels except the one with the SOLO function enabled.
- **MUTE:** MUTE: mutes audio for this channel.
- **POLARITY:** allows the output signal phase to be inverted (180 degrees shift).
- **MODE:** MONO or STEREO. Selecting the STEREO mode associates this output to its counterpart (normal output pairs are 1&2, 3&4, 5&6, 7&8, 9&10, 11&12, 13&14 or 15&16) as a stereo output displayed as a single output (OUT 1 / 2 or OUT 3 / 4, etc.) in the output list, processing settings being equally applied to both outputs. When you select STEREO, the odd channel settings are assigned to the pair of channels. If you split them again, each output returns to the settings it had before linking. In the MATRIX display, STEREO inputs are displayed separately and are identified by their "link" symbol lit.



If **Link channels** mode is enabled in the **MATRIX section** (chain link symbol) in addition to stereo mode, levels and mute function of the 2 crossing points between these inputs and outputs are synchronized (see examples in [INPUTS column section](#)).

9.1.7.2. CROSSOVER

The CROSSOVER section contains the FILTER TYPE and FREQUENCY parameters for each of the two filters (low-pass and high-pass) constituting the crossover. It usually splits the audio frequency spectrum in two parts, creating the two bands usually used in two-way speakers.

- **FILTER TYPE:** allows you to select the crossover filter type. You can select one of the following filter types.
 - Butterworth 6, 12, 18 or 24 dB/oct
 - Bessel 12, 18 or 24 dB/oct
 - Linkwitz-Riley 12 or 24 dB/oct

Note: selecting one or another type of crossover filter automatically adjusts the number of filters available in the parametric equalizer for that channel. Using a 6 or 12 dB/oct crossover filter depletes one of the filters available in the parametric equalizer, while using a 18 or 24 dB/oct crossover filter depletes two filters.

- **FREQUENCY:** adjusts the filter cut-off frequency within the 20 Hz - 20 kHz range.



9.1.7.3. PARAMETRIC EQ

This section groups the parametric filters available for each output channel, very useful to correct the frequency response. If no crossover filters are used in the channel, there will be a maximum of 8 parametric filters freely available, while using crossover reduces the number of available parametric filters, between 7 and 4 (value automatically updated when crossover filters are operated). See

CROSSOVER section

Available parameters are described below. After selecting one of the filters (its numerical indicator is filled, as filter 3 in the picture), its parameters are displayed and their setting is enabled:



The white outer ring indicates that the filter is enabled. The white fill indicates the selected filter.

- **ENABLE/DISABLE:** enables/disables the parametric EQ, affecting all filters from this section. When the value is DISABLE (top left button greyed out), there is no filter processing (equivalent to BYPASS filters). In the opposite case (green button), EQ is enabled, and its operation depends on the rest of the parameters in this section
- **FILTER TYPE:** type of filter used. You can select one of the following filter types (adjustable controls for each filter type are shown between brackets):
 - **Bypass:** filter not used. Bypassed filters have a grey circle around their numbers (filter #2 or 4 in the picture), while operating filters (not in bypass mode) have a white circle (filter #1 or 3 in the picture)
 - **Parametric EQ (FREQUENCY, GAIN, Q):** classic parametric equalizer filter with adjustable central frequency (between 20 Hz and 20 kHz), gain or attenuation at central frequency (between +12 dB and -60 dB) and bandwidth (1/Q, Q between 0.3 and 200).
 - **Low-Shelf and High-Shelf with a 6 or 12 dB/oct slope (FREQUENCY, GAIN):** shelving type filters with adjustable cut-off frequency (between 20 Hz and 20 kHz) and gain or attenuation (between +12 dB and -60 dB).
 - **Low-Pass y High-Pass with a 6 or 12 dB/oct slope (FREQUENCY):** these are low-pass and high-pass filters with adjustable cut-off frequency (between 20 Hz and 20 kHz).

- **All-Pass order 1 and 2 (FREQUENCY in both, Q in order 2 only):** all-pass filters that do not affect the signal amplitude, but the phase at certain frequencies (in contrast with delay, which changes phase at all frequencies). The main application of this type of filter is usually to compensate phase errors in speakers or phase shifts introduced by crossover filters

NOTE (from v4 onwards): New EQ export / import feature that allows to export the EQ section from devices like MIMO88, MIMO88SG, MIMO1212SG, MIMO88

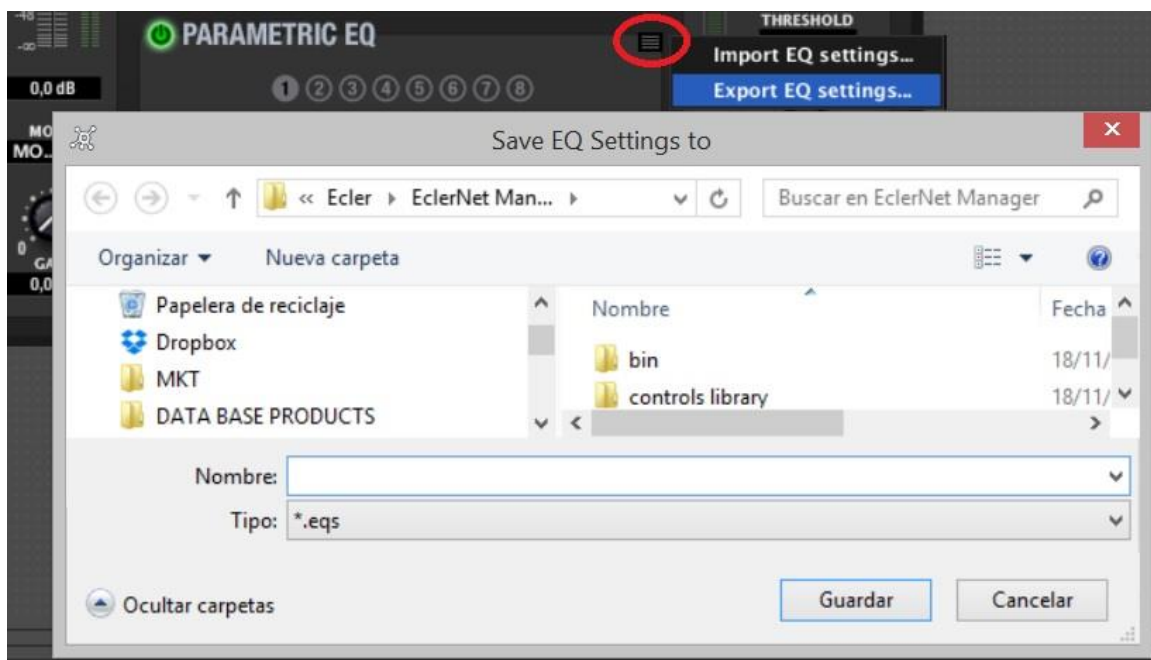

CONFERENCE, NXA series, etc. to a *.eqs file that can be imported in other devices:

- **It's available just when the EQ section is ON**
- **Exporting an EQ set with 8 filters (for instance, MIMO88 output EQ), for instance, to a device that supports 6 filters (like NXA units) will result in ignoring filters 7 and 8.**

9.1.7.4. DELAY

The DELAY section allows you to adjust an independent time delay for each output channel. This function is useful for example to temporarily align the



different ways of a loudspeaker cabinet, using an output with a corresponding delay for each one of them.

The delay time can be specified in different units, which are determined by the UNITS selector (up and down arrows to the right of the text box). Available units are milliseconds, seconds, centimetres and meters. DELAY can be set between 0 and 1000 milliseconds.

To avoid weird and annoying noises in the output signal, the value change made with the DELAY potentiometer is not effective until the mouse button is released. At that time audio will be temporarily muted (for a variable time, depending on the delay value used) for the new setting to be effective.

9.1.7.5. LIMITER

The limiter section offers a dynamic processing of the output signal, allowing you to limit its maximum level. This function is very useful for example when you want to moderate the maximum volume produced by the speakers of the system for several possible reasons, one of them (very obvious) being to avoid exceeding their power handling capacity to protect them from a failure. Available settings are:

- **ENABLE/DISABLE:** enables/disables the limiter (green button/grey button). When in DISABLE mode, the rest of the section controls are disabled.
- **THRESHOLD:** limitation threshold. Specifies the output signal level at which limitation begins to occur. This parameter ranges from +18 dB to -36 dB.
- **GR (Gain Reduction):** VU meter-like indicator of the limitation applied to the signal, displaying in decibels the reduction of the limiter output signal compared to the input signal
- **ATTACK:** attack time. Determines the time the limiter takes to respond when the output level rises above the threshold. The range covers from 0.1 ms to 500 ms
- **RELEASE:** determines how quickly the limiter stops acting once the signal output level falls back below the threshold. In this case, the range covers from 10 ms to 1 s.



Setting limiters' ATTACK and RELEASE times correctly is not an easy task: too short release or attack times result in excessive and perceptible low frequencies distortion; on the other hand, too long times could make a limiter useless since it would act too late, letting high intensity signal peaks pass through.

9.1.8. MIMO88 PAGERS/DUCKERS section

The PAGERS/DUCKERS section of a MIMO88 device has the following appearance:



This section lets you configure the four application modules based on the attenuation (or muting) of an audio signal by another signal, allowing the diffusion of messages or other audio content with priority over other signals. These modules are named "P/D module 1 " to "P/D module 4" (short for "Pager/Ducker Module 1, 2, 3 or 4") and any of them can be configured as pager (real-time voice announcement for destination zones selected through an eMPAGE or MPAGE16 console, for example) or "ducker" or "override" (an audio signal has priority over all other ones that are attenuated or muted in the selected destination zones.)

From this section it's not possible to operate PAGER modules as usual (selecting destination zones of the PAGER, activating the PAGE or DUCK function, etc.), but only to set performance parameters and enable/disable possible destination zones.

It is important to notice that the configuration of the PAGERS/DUCKERS section can be stored in Presets, so that different Presets define different destination zones and settings for these 4 modules.

In the list of the left side of the section one of the four modules can be selected then configured using the controls on the right side (TYPE, INPUT, PRIORITY, etc.).

9.1.8.1. Configuring a module as PAGER

This operating mode of the PAGER/DUCKER modules is suitable for the configuration of a voice announcement system in real time or "paging" through an eMPAGE or MPAGE16 console. With the eMPAGE / MPAGE16 unit, you can select a number of destination zones and send them the voice messages (announcements), reducing the existing audio content volume during the emission of the message.

Note: Although the description of this section focuses on the module configuration for connection to an eMPAGE / MPAGE16 console, it is also possible to control a module configured as PAGER in other way from EclerNet remote clients.

It is important to notice that the configuration of the DUCKER section can be stored in *Presets*, so that different *Presets* define different destination zones for a PAGER module.

Once one of the four modules has been selected in the list, its operating mode as PAGER is chosen using the TYPE selector.

Then, the INPUT selector defines the MIMO88 audio input your eMPAGE / MPAGE16 console microphone will be connected to in order to send voice messages. The list shows the 8 or 16 available inputs of the system, depending on the 8x8 or 16x16 configuration (2 MIMO88s linked as MASTER-SLAVE). It is highly recommended to use a high-pass filter to process this input (120 or 150 Hz) in order to eliminate a great part of the ambient noise and LF interferences from the incoming signal, especially in applications with long runs of wiring. See [PARAMETRIC EQ](#) section.

The PRIORITY selector determines the module priority level between 1 and 4, level 1 being the highest priority. In a configuration with two consoles having different priority levels, each using one PAGER modules, the console with the highest priority may interrupt the lower priority one in case of overlapping in the destination zones during the emission of a message (i.e. while the areas are retained). This interruption may be total or partial in terms of message length, and affects only those areas where there is overlap. When the two consoles have the same priority level, the first one that holds a zone (or several) has priority for the duration of the message, holding the zone(s) up to their release.

Priority management and zones holding as explained in the previous example (two PAGER modules assigned to two hardware eMPAGE / MPAGE16 consoles) is also applicable in other cases: two DUCKER modules or one DUCKER module + one PAGER module.

You can include a brief chime melody in each message sent, usually as a warning of message start. Two melodies (MELODY 1, MELODY 2) or NONE can be selected with the CHIME selector. Every time a console starts sending a message using the PAGE key, the selected melody is first heard in the destination zones so that at the next step the console user can send the voice message.

The destination zones keys in the central part of the section (1 to 8 or 1 to 16, depending on the MIMO88's operating mode, 8x8 or 16x16) allow you to enable or disable zones by a double-click. When a zone is enabled (filled in white) the eMPAGE / MPAGE16 console may select it as destination of its message, whereas when it is disabled (unfilled) the console can't select it as a destination. Even if an output channel is set to stereo, you can enable/disable any of the two zones that compose it from this configuration screen. If an output channel is set to stereo, selecting/releasing a zone from the eMPAGE / MPAGE16 also selects/ releases the other, if it was enabled.



Example: module #1 configured as PAGER, audio input IN5 and zones 2, 3, 4, 9 and 11 enabled for messages sending from an eMPAGE / MPAGE16 console

In addition, each key includes a light indicator with different colour codes to indicate the zone status. The "tooltip" indicator that appears when the cursor is positioned over a key also displays its status. These indications match those given by the physical eMPAGE / MPAGE16 console with its key LEDs:

- Unlit: free zone (not hold by another console, if any)
- Lit in green: zone selected by the console to broadcast the following message
- Lit in red: zone not selected in the console, but hold by another highest priority console (or DUCKER)
- Lit in orange: zone selected by the console, but hold by another highest priority console (or DUCKER)

The **PAGE** key is a representation of the hardware **PAGE** key from the eMPAGE / MPAGE16 console, just for status information given by the colour of the light, since it does not allow you to enable or disable any function of the **PAGER** module. The **PAGE** key of this section is lit while you hold down the **PAGE** key from the eMPAGE / MPAGE16 console to indicate that the console is entering the message sending mode:

- Lit in orange: when you start sending a message (pressing and holding the **PAGE** key), it indicates that the chime melody is played (as determined with **EclerNet Manager** for the control programming), then turns green at the end of the chime. Thus, the speaker knows when the chime ends and can start its speech without overlapping the chime broadcasting
- Lit in green: paging function activated with voice message broadcasting to selected destination zones (duration of the voice message)

Knobs on the lower part of the section are used to adjust the way the **PAGER** function performs:



- **CHIME VOL**: playback volume of the chime melody (-12 to 0 dB). This melody and the input channel associated with the **PAGER** (signal of the microphone connected to a MIMO88 input) are mixed, the effective volume being affected by the general volume of the input channel (see [LEVEL section](#)). The level meter of this input channel also reflects the playback of the chime melody
- **DEPTH**: attenuation applied on the rest of the signals sent to the destination zone(s) during the time the **PAGER** function is active (0 to 80 dB)
- **ATTACK**: attack time. Determines the time elapsed since the activation of the **PAGE** key until signal attenuation starts. The range covers from 5 ms to 2 s
- **RELEASE**: determines the time elapsed until attenuation stops once you release the **PAGE** key. In this case, the range covers from 50 ms to 3 s.

Note: For outputs an input should send messages to through a pager module, the crossing points of the matrix between this input and all possible outputs should be **in MUTE status**. The PAGE action momentarily removes the MUTE for the selected input in the pager and activates the MUTE or attenuation for all other inputs. The distribution volume to each of the outputs is independently set by the volume of the crossing point. When outputs an input should send messages to through a pager module have an unmuted matrix intersection between this input and all possible outputs, input signal will be broadcast without needing to activate PAGE from the console or the user screen.

9.1.8.2. Configuring a module as DUCKER

This operating mode of PAGER/DUCKER modules is suitable for the configuration of a voice announcement system in real time via a microphone (handheld, desktop, headset, etc..) or pre-recorded voice messages played on an external audio file player. The announcement signal is broadcast in the destination zones, the rest of the signals played back in these zones being attenuated. The selection of destination zones or outputs affected by the DUCKER function can be done by programming MIMO88 with EclerNet Manager or in real time from EclerNet Manager remote clients. It is important to notice that the configuration of the DUCKER can be stored in Presets, so that different Presets define different combinations of destination zones for a PAGER module.

Once one of the four modules has been selected in the list, its operating mode as DUCKER is chosen using the TYPE selector.

Then, the INPUT selector defines the MIMO88 audio input your microphone, audio player or sound source will be connected to in order to act as a trigger of the DUCKER function. The list shows the 8 or 16 available inputs of the system, depending on the 8x8 or 16x16 configuration (2 MIMO88s linked as MASTER-SLAVE).

The PRIORITY selector determines the module priority level between 1 and 4, level 1 being the highest priority. In a configuration of two DUCKER modules with different priority levels, the module with the highest priority may interrupt the lower priority one if destination zones overlap during the emission of a message. This interruption may be total or partial in terms of message length, and affects only those areas where there is overlap. When the two modules have the same priority level, the first one that holds a zone (or several) has priority for the duration of its message, holding the zone(s) up to their release.

Priority management and zones holding as explained in the previous example (two DUCKER modules) is also applicable in other cases: two PAGER modules or one DUCKER module + one PAGER module.

The destination zones keys in the central part of the section (1 to 8 or 1 to 16, depending on the MIMO88's operating mode, 8x8 or 16x16) allow you to select the destination zones for a PAGER module by a mouse click. If a zone is selected (green LED indicator), the DUCKER module will affect it when the input signal exceeds the threshold. Even if an output channel is set to stereo, you can select or deselect any of the two zones that compose it from this configuration screen.

The light indicator inside the keys has different colour combinations to indicate the zone status. The "tooltip" indicator that appears when the cursor is positioned over a key also displays its status. Possible status:

- **Unlit:** free zone (not hold by another DUCKER or PAGER, if any)
- **Lit in green:** zone selected by the DUCKER to broadcast the following message
- **Lit in red:** zone not selected in the DUCKER, but hold by another highest priority DUCKER (or PAGER)
- **Lit in orange:** zone selected by the DUCKER, but hold by another highest priority DUCKER (or PAGER)

The DUCK key gives is a representation of the active or inactive status of the DUCK function for the selected module that doesn't allow you to enable or disable any function of the DUCKER module. It lights up in green when the DUCKER function is active.



Example: module #2 configured as a DUCKER, audio input IN6 and zones 1, 3, 13 and 15 enabled for priority broadcasting of IN6 signal when it exceeds the threshold, attenuating the existing audio content in the affected outputs

Knobs on the lower part of the section are used to adjust the way the DUCKER function performs:

- **THRESHOLD:** activation threshold. When the module's input signal (INPUT selector) exceeds this threshold, the DUCKER function is activated, sending the signal to the destination zones and attenuating the other audio signals sent to the same zones (-80 to 0 dB)
- **DEPTH:** attenuation applied on the rest of the signals sent to the destination zone(s) during the time the DUCKER function is active (0 to 80 dB)
- **ATTACK:** attack time. Determines the time the DUCKER takes to respond when the level rises above the threshold (activating the attenuation of other signals in the destination zones). The range covers from 5 ms to 2 s
- **HOLD:** amount of time the DUCKER function remains active once the signal falls back below the detection threshold. Adjustment range from 10 ms to 3 s
- **RELEASE:** determines the time elapsed until attenuation stops after the time fixed for HOLD. In this case, the range covers from 50 ms to 3 s.

9.1.9. MIMO88 GPIs/GPOs section

GPIs/GPOs section basically allows two functions:

- Monitoring the 0 - 10 VDC signal detected in GPI inputs (8 or 16 inputs, depending on whether it is a MIMO88 or a couple MASTER-SLAVE). The monitoring is displayed in the window under the GPI name (GPI1, GPI2, etc.) and as a percentage of the maximum possible value (0 to 100%)
- Monitoring and modifying the GPI output status (8 or 16 outputs, depending on whether it is a MIMO88 or a couple MASTER-SLAVE).

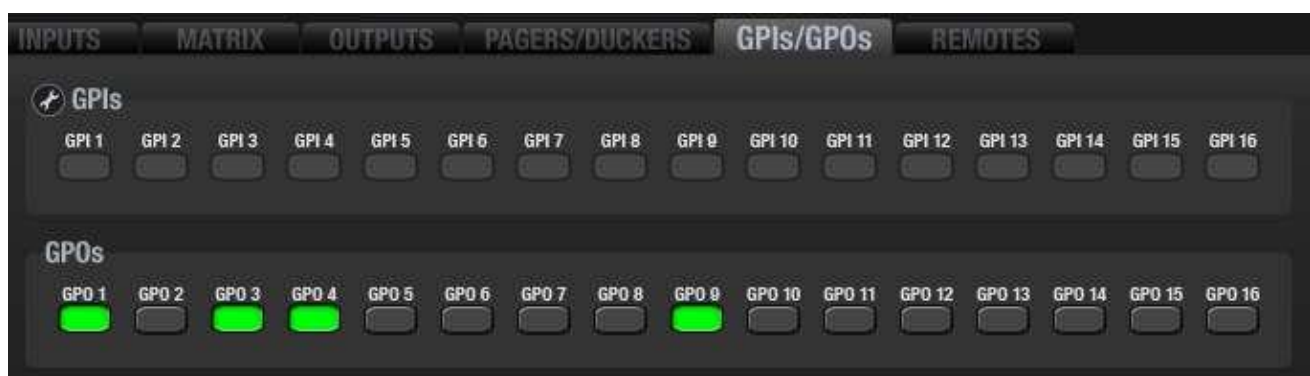

MIMO88's GPI and GPO ports allow you to connect external control hardware and to interact with these units: potentiometers, push buttons, limit switches, lights, motors, etc.

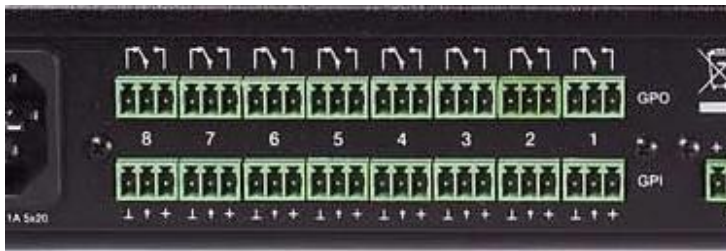

A GPI port (General Purpose Input) is a MIMO88 physical connection that lets read the DC voltage applied to it, and that can vary within the range of 0 to 10 VDC (0 to 100% in the screen readings,

GPI 1
0). This is a control input (no audio), linkable to EclerNet Manager virtual controls and therefore to the MIMO88. Each GPI port has 3 contacts: ground, detection terminal and +VDC (pictured from left to right). Thus, it is possible to feed a passive element such as a potentiometer, using the power supplied by the GPI port itself, as in this example:

Positive, + 10 VDC	>	Pin +
Variable voltage, 0-10 VDC	>	Pin ↑
Ground	>	Pin ↓

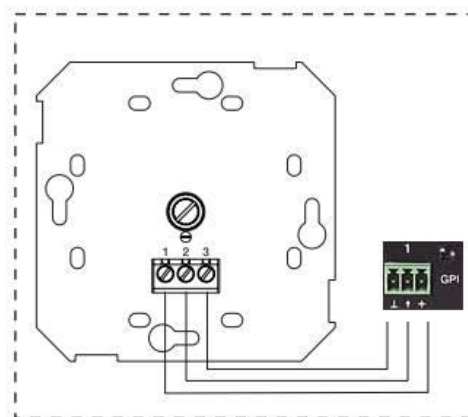

See the MIMO88 hardware manual for other options of connection to GPI ports.

In the following example, connecting a potentiometer to a GPI port and turning it will give its cursor a variable voltage between 0 and 10VDC. We can associate this GPI input with the MIMO88 volume control, and thus have a remote volume control by external hardware like a WPmVOL / WPaVOL ECLER (potentiometer):

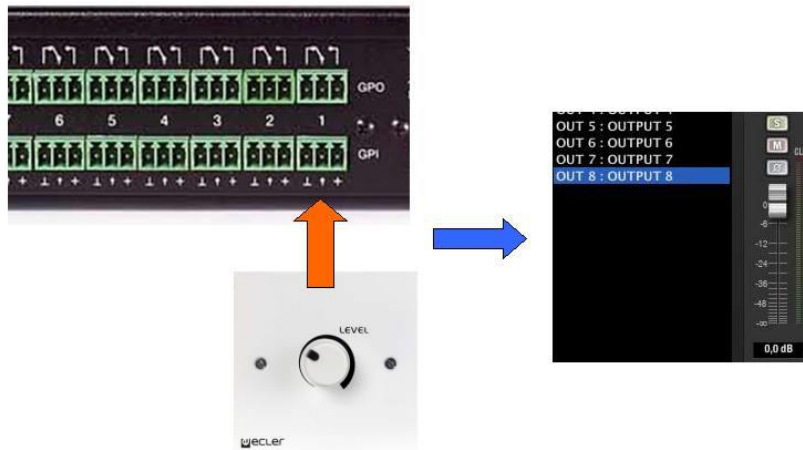

The picture is a representation of a WPVOL physically connected to the GPI 1 and assigned to the volume of MIMO88's output 8 by EclerNet Manager programming

GPI management is done from the EVENTS section of EclerNet Manager (see **MIMO88 EVENTS section**).

Sometimes, especially with long runs of cable between a knob or button and the MIMO88 and, consequently, a considerable voltage drop, detection terminal will not receive a voltage very close to 0 and/or 10 VDC (potentiometer to the minimum and maximum, external contact opened and closed, etc.). In this case, it may be desirable to calibrate the minimum and maximum voltage received by the GPI port, so that the MIMO88 might rescale all the possible range of tensions received at that port and work properly with assigned parameters.

The calibration process is done by clicking on the configuration wrench icon in the [GPIs/GPOs section](#):



The configuration screen that opens looks like:



Example for calibrating a WPmVOL / WPaVOL hardware potentiometer connected to GPI #2 to remotely manage a volume control of MIMO88:

1. Place the pot on the end that provides a minimum reading (in our case 7)
2. Click on the **Read Current GPI value** button:



3. Place the pot on the end that provides a maximum reading (in our case 83)
4. Click on the **Read Current GPI value** button:

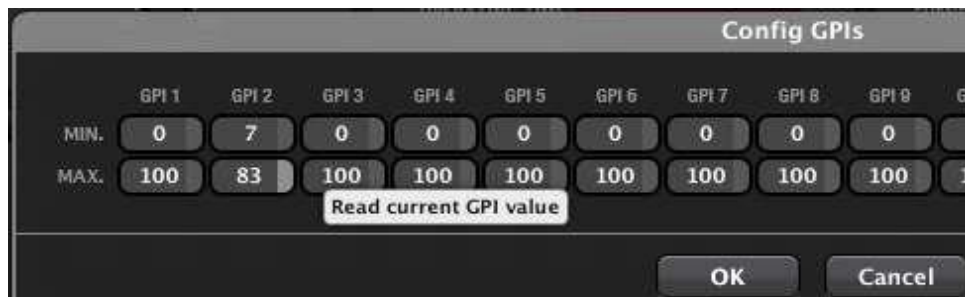

5. Accept the changes with OK.

A GPO port (General Purpose Output) is a relay with a common contact and two contacts: NO (Normally Open, with the relay at rest) and NC (normally closed, with the relay at rest). From the GPIs/GPOs section it is possible to enable or disable the GPO ports of a MIMO88 unit by clicking on them. When you activate a GPO, contacts are reversed: contact closes for NO and opens for NC. Contacts at rest are filled in grey and active contacts light up in green:



In the picture the GPO 1, 4, 5 and 7 are active and the rest of them are inactive

GPO status (active or inactive) is stored in the *Presets*, so that recalling one of them also recalls the existing combination of active/inactive GPOs at the time of storage.

GPO management can also be done from the **EVENTS** section of EclerNet Manager (see **MIMO88 EVENTS section**).

See the MIMO88 hardware manual to know current limitations of GPO ports.

9.1.10. MIMO88 REMOTES section

REMOTES section allows you to identify and configure the different hardware remote controls connected to a MIMO88 unit, that may be ECLER WPTOUCH (digital touch wall panel), MPAGE16 (desktop digital paging station with touch-sensitive keys), eMPAGE (substitute of the MPAGE16 - JAN19 onwards-, desktop digital paging station with e-ink screen for destination zones labelling) or even ECLER WPmVOL-SR / WPaVOL-SR (analogue wall panels for source selection and volume control).

Remote controls operate available functions of the MIMO88, allowing the end user to friendly control certain parameters of the installation using a classic and familiar looking hardware control. These are basically the following functions:

- Adjust volume of inputs, outputs or crossing points of the audio matrix
- Toggle MUTE controls (inputs, outputs, crossing points)
- Select sound sources (audio inputs connected to the matrix) for certain destination zones (matrix audio outputs)
- Select *Presets* (MIMO88 configuration memories)
- Send voice messages to certain destination zones

The window displayed after selecting the REMOTES tab looks like this one:



On the left, remote controls assigned to this MIMO88 unit appear in the REMOTE LIST (this list is empty by default when entering the REMOTES section for the first time in a project.) Every time we add, delete or edit the name of one of them in our project, the list is updated. Remote controls included in the list may be further configured to perform the desired functions.

Concerning the maximum number of digital remote controls:

- **WPTOUCH:** the MIMO88 can handle a maximum of 16 WPTOUCH units, both in single mode (8x8) and MASTER-SLAVE mode (16x16)
- **eMPAGE / MPAGE16:** the MIMO88 can handle a maximum of 4 paging console units, both in single mode (8x8) and MASTER-SLAVE mode (16x16)

Note: EclerNet Manager must be set in **DESIGN** mode (not DEPLOY) to enable configuration functions detailed in this chapter for remote panels.

The  icons respectively allow you to (from left to right):

- **Add Online and Unused Remote:** as a MIMO88, MIMO88SG, MIMO1212SG, NXA MIMO4040DN, NPA unit, etc., a digital remote device features the "Auto Discover" function, i.e. when connected to the ER-Bus (REMOTE 1 or REMOTE 2 connector on the rear panel of the MIMO88) it is automatically identified or "scanned" by the application. Clicking on the "Add Online and Unused Remote" icon displays a list of all "scanned" digital remote controls. You can select the ones to assign to the MIMO88 unit, becoming part of the REMOTE LIST

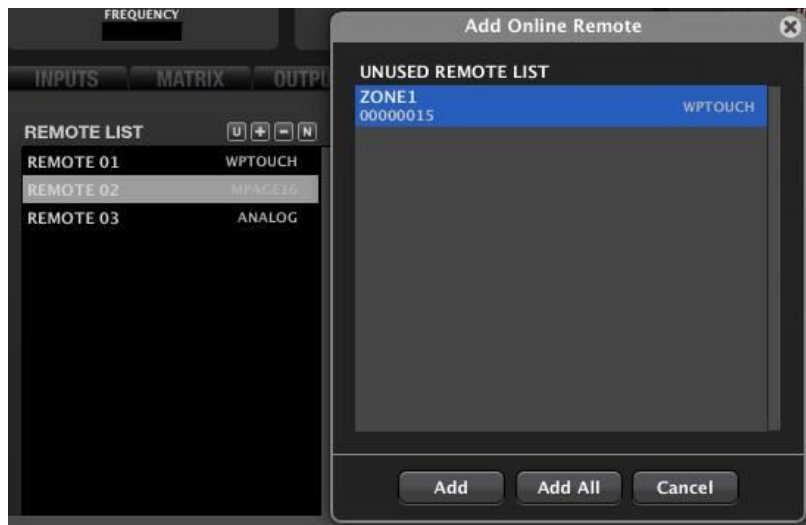

WPTOUCH digital remote control automatically detected

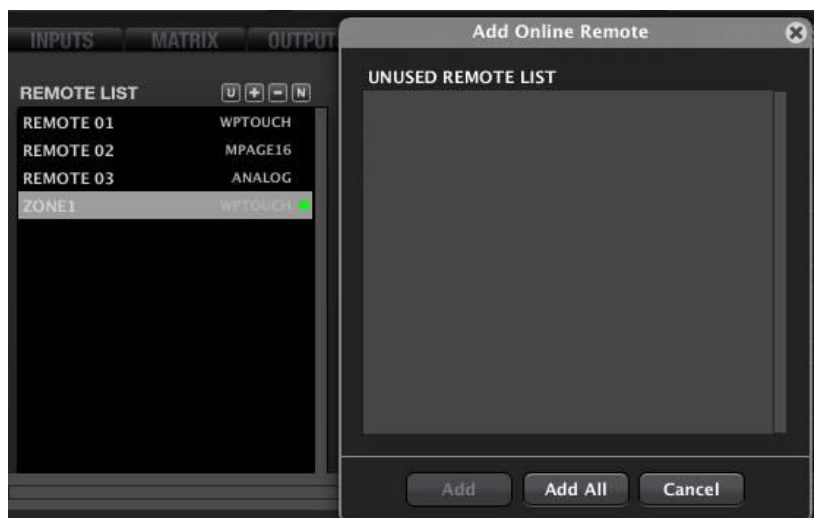

The same control once added to the REMOTE LIST

- **Add New Remote:** to manually add a WPTOUCH (digital), eMPAGE / MPAGE16 (digital) or ANALOG (WPMVOL-SR / WPaVOL-SR type) remote control to the REMOTE LIST



- **Remove Remote:** to remove one of the devices from the REMOTE LIST

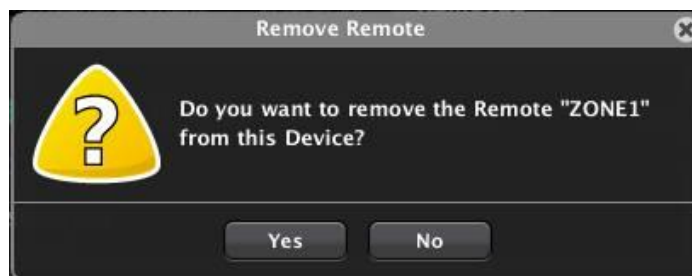

- **Change Remote Name:** to change the name of a remote control from the REMOTE LIST

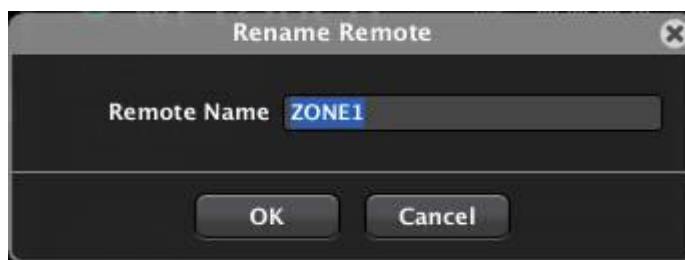

The digital remote controls have a status icon located to the right of their name and model in the list (green for the "ZONE1" remote control in the picture):



This icon lights up differently to indicate distinct states:

- **Unlit:** the virtual remote control (from list) is not associated with any hardware device
- **Steady red:** the hardware device associated with the virtual remote-control panel is not "online" (the MIMO88 unit it depends on is disconnected)
- **Flashing red:** the hardware device associated with the virtual remote-control panel has been detected "online" by the MIMO88 (the MIMO88 unit it depends on is connected, but the remote control is disconnected)
- **Steady green:** both MIMO88 hardware and the remote control are "online" and operational
- **Flashing green:** the operating MIMO88 and the remote control are "online" but not operational (*firmware-software versions are not compatible*)

Remote controls from the REMOTE LIST also have a context menu (right button of the mouse):

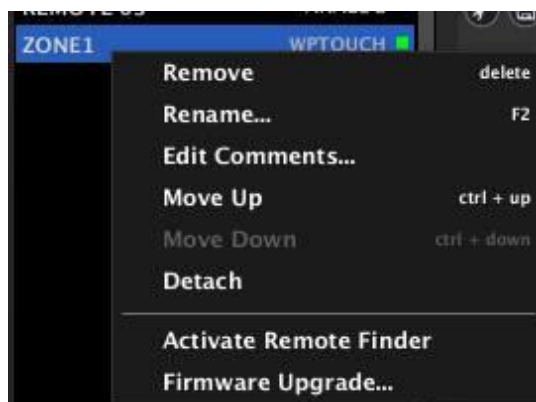

- **Remove:** to remove the device from the REMOTE LIST
- **Rename:** to change the name assigned to a device
- **Edit Comments:** to add a text field with personalized comments about the remote device:

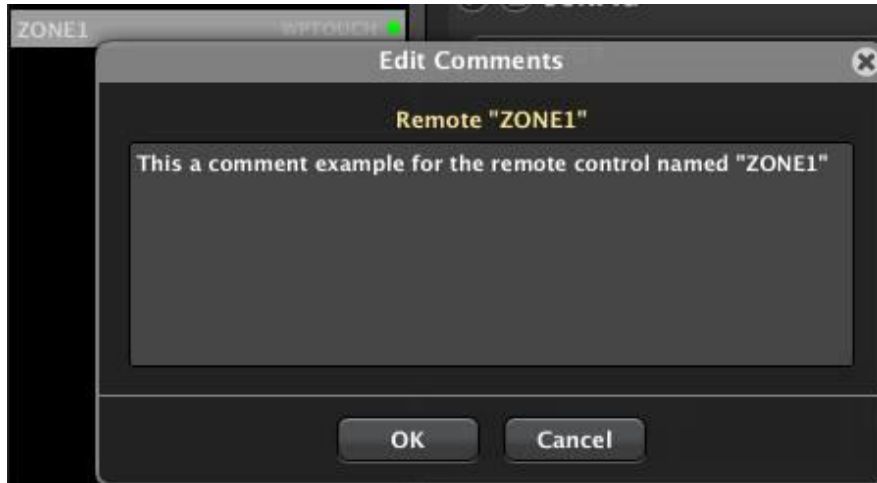

- **Move Up:** the device moves up one position in the list
- **Move Down:** the device moves down one position in the list
- **Attach/Detach:** to attach or detach a digital device in the list (virtual) to/from a hardware digital device automatically detected:

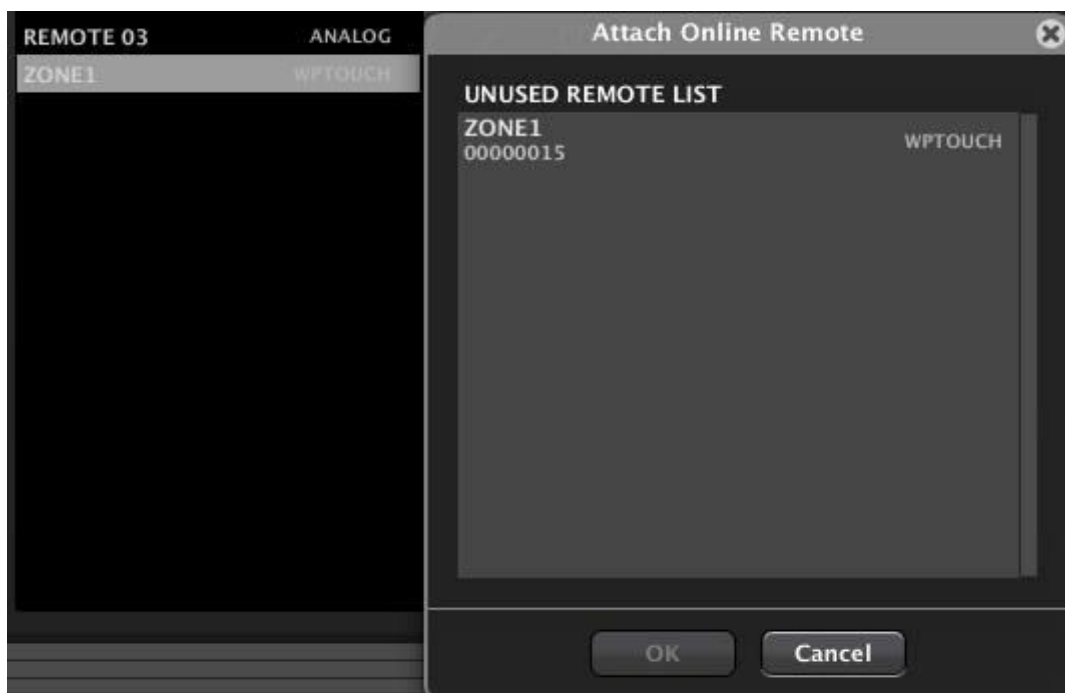

- **Activate Remote Finder:** activates/deactivates the blinking of the front panel light indicators (LCD display for WPTOUCH, LEDs for eMPAGE / MPAGE16 series) on the concerned digital hardware remote control panel, thus allowing easy identification on site. Simultaneously, the frame of the device shown in the REMOTES LIST also blinks, making it possible to link a virtual device of the Project with its hardware counterpart, to check its identity before changing its settings.

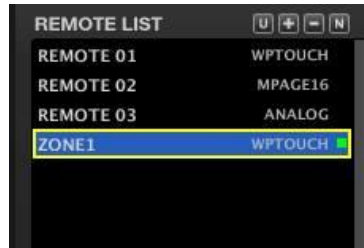

Flashing yellow frame after the Remote Finder activation

- **Firmware Upgrade:** opens a dialog box that allows you to load a remote device firmware file (with .bin extension) and to transfer it to the related device. The device must be "online" to perform this operation.

Here is the procedure for setting different types of remote control that can be connected to a MIMO88

9.1.10.1. Configuring a WPTOUCH-type remote control

The WPTOUCH is a digital remote-control panel for wall mounting featuring the following elements:

- LCD display
- touch-sensitive jog wheel
- 2 touch-sensitive keys (hereafter T1: left key, T2: right key)
- IR receiver



The LCD screen, the T1, T2 keys and the wheel are programmable from EclerNet Manager for the WPTOUCH to perform certain actions in order to control and display information.

The wheel control is by default the volume control (**Volume mode**) allocated with the programming. In addition, it may act as a selector (**Selection mode**) for the sound sources associated with a particular zone, or as a Preset selector.

WPTOUCH possible working modes are:

- **NORMAL:** the jog wheel is by default the volume control, as the panel is by default in **Volume mode**. To switch from **Volume mode** to **Selection mode**, you must press T2, turn the control wheel to make the desired selection change and press T2 again to confirm. A triangular index to the right of the LCD screen indicates whether the unit is in Volume

adjustment mode (pointing the bottom row of characters) or Selection mode (pointing the top row of characters)

- **SIMPLE (*)**: the top line in the LCD shows the current selected source, and the bottom line shows the currently adjusted volume level. The jog wheel function is by default the volume control one, as the panel is by default in **Volume mode**. A short press of T1 key enters into **Selection mode**, where the control wheel rotation switches among the available audio sources / presets, with immediate changes and no need for confirmation by a new key press. A timeout of 3 seconds with no panel's gesturing, or a T2 key press will bring the panel back to the default **Volume mode**

(*) Note: SIMPLE mode is available from ENM software version v4.o3r2 and WPTOCUH firmware version v1.02r2 (April 2018)

When selecting a WPTOUCH unit in the REMOTE LIST, its detailed configuration screen is displayed on its right:



In its upper part, the display includes:



- **Enable/Disable Remote button:** to enable (lit in green) or disable each WPTOUCH unit connected to the MIMO88. **The state (enabled or disabled) of remote controls is stored in a system Preset when you save it, so that you can manage which remote controls are enabled or not by recalling each Preset** (e.g. when loading a Preset for asking to evacuate a building with a pre-recorded message, all remote controls of the installation are disabled to avoid user interferences in such special scenario in which the evacuation message prevails on the rest of the audio signals...).
- **HID indicator:** hardware ID (assigned at the factory, unique to each unit and not editable by the user)
- **Firmware indicator:** unit's firmware version

The lower portion of the WPTOUCH configuration screen includes the following controls:

- **MODE:** NORMAL or SIMPLE working mode. (*)
- **LCD BACKLIGHT:** turns the backlight on/off for the WPTOUCH LCD display when touched by the user. When this feature is enabled (ON), the LCD display lights up when touched, the light disappearing within a few seconds after the end of the contact
- **VOLUME MIN and VOLUME MAX:** performance range of the volume control from the wheel in Volume mode. It prevents a user to exceed a given maximum volume or to fall below a minimum volume. Default values are respectively 0 and 100%

(*) **Note:** SIMPLE mode is available from ENM software version v4.03r2 and WPTOCUH firmware version v1.02r2

Now comes the WPTOUCH configuration area:

- The  (Change Configuration) icon gives access to the configuration parameters of the unit
- The  (Save Configuration in Remote) icon stores the WPTOUCH device configuration

Clicking on the  icon opens the WPTOUCH configuration window:

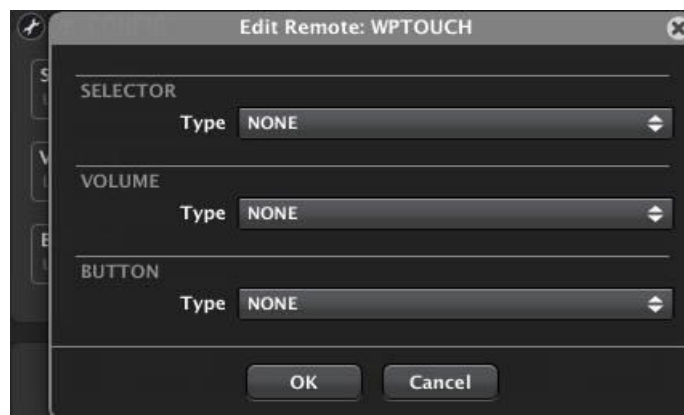

The configuration of a digital remote control as the WPTOUCH depends on a Project but not on a Preset (you can't save distinct WPTOUCH settings in different Presets within the same Project).

The first option to select for the unit is the control wheel function in Selection mode:



- **NONE**: selection function is disabled for this WPTOUCH unit
- **CARROUSEL**: selection function is enabled

When selecting the CARROUSEL mode, a new menu appears to select which carousel list (it must have been previously created) will be assigned to the unit. A carousel list contains the available options for selecting either the input sound sources (Inputs) or the MIMO88 Presets from a WPTOUCH unit in Selection mode. See **Carousel lists for MIMO88** section for more information about the creation of carousel lists.

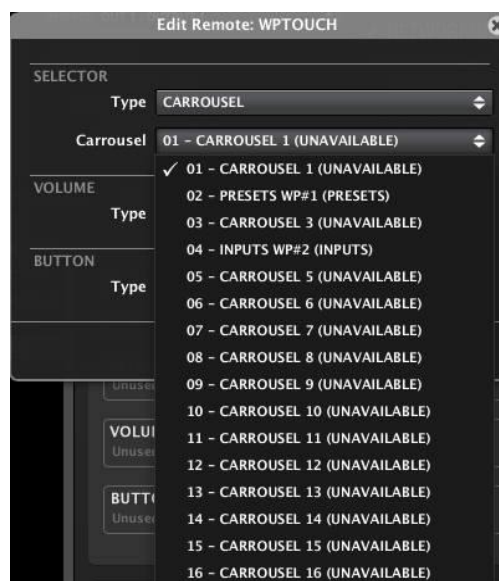

Depending on whether you select a **carousel of inputs or Presets**, configuration options will differ from this point:

9.1.10.1.1. Configuring the WPTOUCH for operating with a carousel of Presets

After selecting a carousel list of Presets for the Selection mode of a WPTOUCH, you can make this selection from the WPTOUCH unit as follows:

NORMAL MODE:

- Pressing T2 switches to the Selection mode (the triangular icon to the right of the LCD screen moves up to the upper row)
- with the wheel, select one of the Presets contained in the carousel list
- Pressing T2 again confirms the selection, the Preset is recalled and the triangular icon returns on the bottom row (back to Volume mode). If T2 is not pressed again, the selection is not validated, no Preset is recalled and the Volume mode automatically returns after a few seconds (triangular icon on the bottom row of the LCD)

SIMPLE MODE:

- A short press of T1 key enters into **Selection mode**, where the control wheel rotation switches among the available presets in the defined carousel list, with immediate changes and no need for confirmation by a new key press. A timeout of 3 seconds with no panel's gesturing, or a T2 key press will bring the panel back to the default **Volume mode**

The following configuration function (VOLUME) lets you select which volume the WPTOUCH wheel controls in the other mode, the **Volume mode** (default mode):

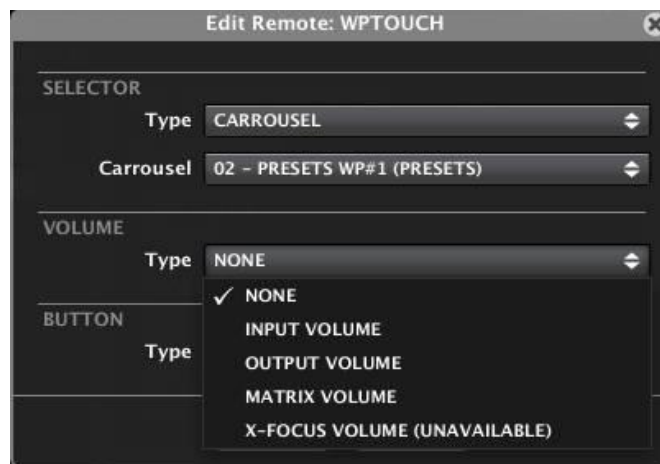

The available options for the VOLUME function are:

- **NONE:** Volume mode disabled
- **INPUT VOLUME:** any input of the MIMO88 unit:

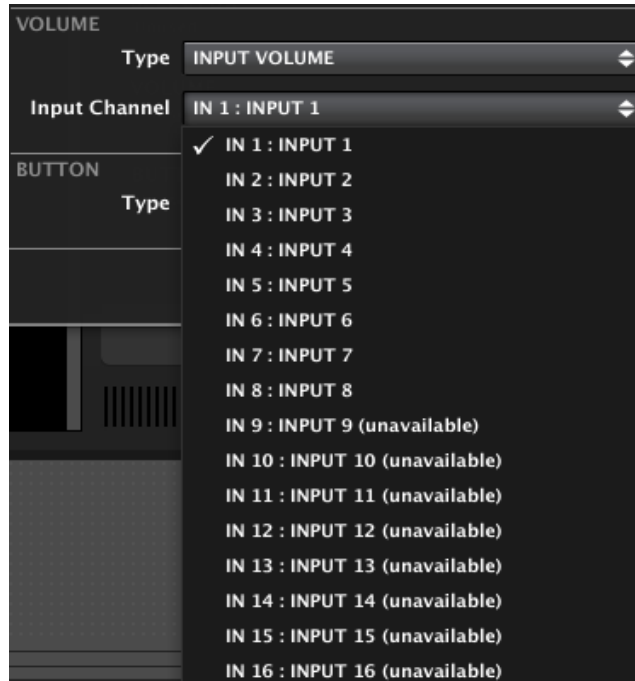

- **OUTPUT VOLUME:** any output of the MIMO88 unit:

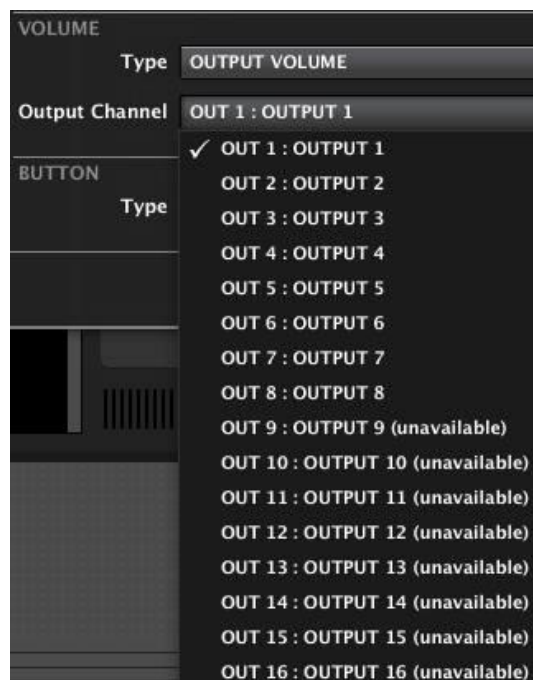

- **MATRIX VOLUME:** any crossing point between an input and an output of the matrix (in this example the crossing point between input 5 and output 3, or amount of signal sent from input 5 to output 3, represented in the matrix by the control knob of the intersection):

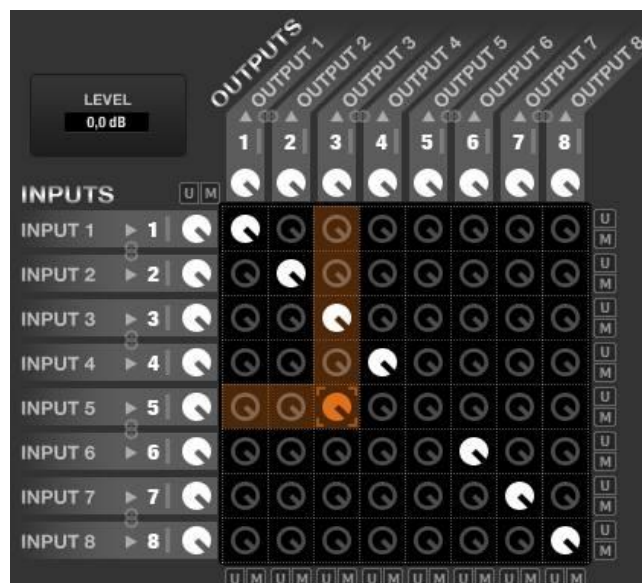
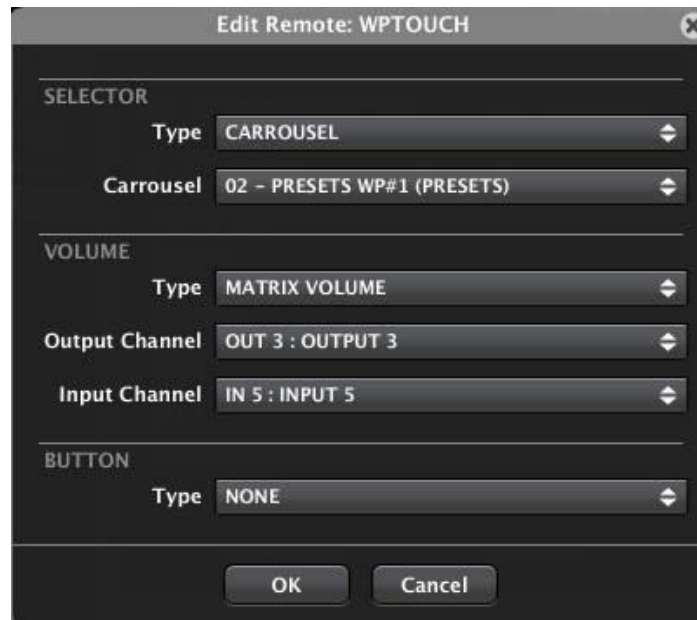

Volume Control selected in the previous example (in orange)

- **X-FOCUS VOLUME:** not available when the WPTOUCH manages a carousel list of Presets.
See **WPTOUCH configuration section** to operate with a **carousel of inputs**

The following configuration function (BUTTON) selects the function assigned to the T1 key of the WPTOUCH (not available for **WPTOUCH SIMPLE mode**, where T1 has a fixed function).

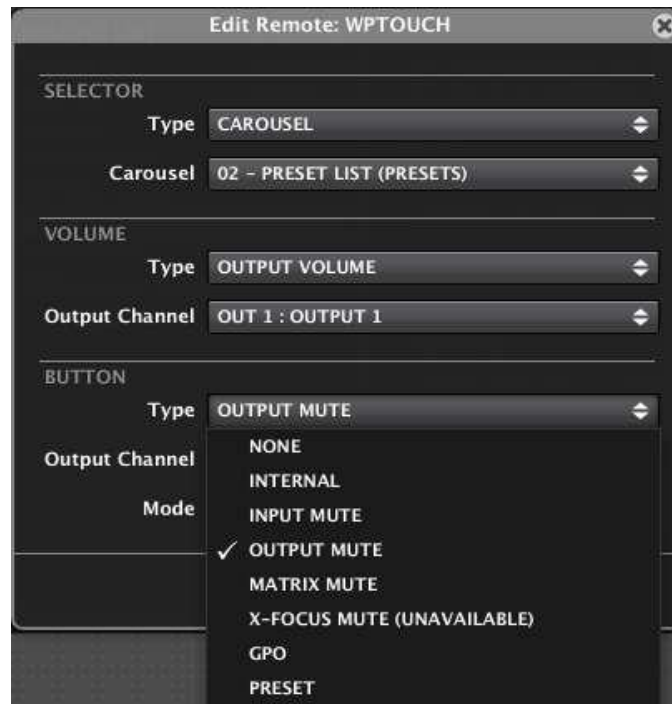

The available options for the BUTTON function are:

- **NONE:** T1 key disabled
- **INTERNAL:** internal output (without direct link to a function) that can be used as input for events
- **INPUT MUTE:** mutes any input of the MIMO88 unit:

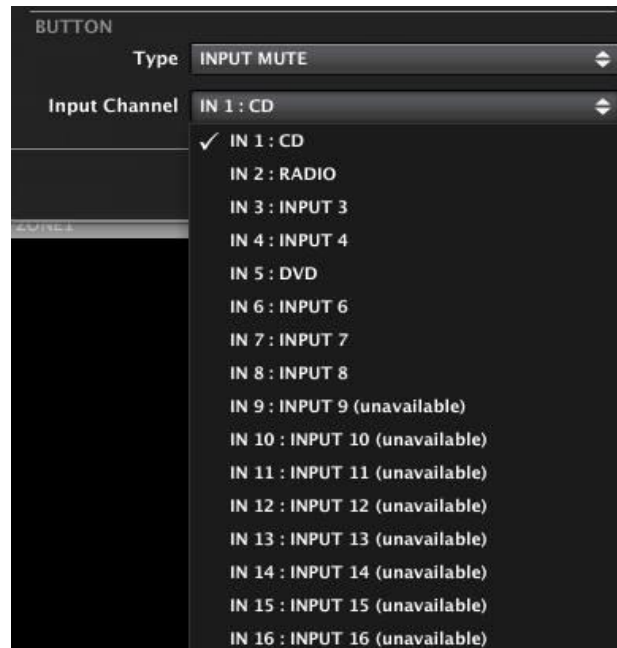

- **OUTPUT MUTE:** mutes any output of the MIMO88 unit:

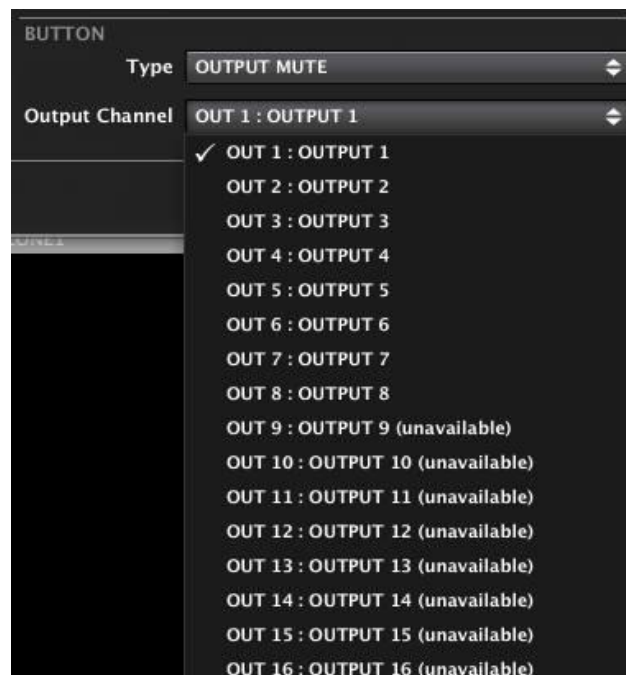

- **MATRIX MUTE:** mutes any crossing point between an input and an output of the matrix (in this example the crossing point between input 5 and output 3, or signal sent from input 5 to output 3, represented in the matrix by the control knob of the intersection: MUTE is ON when unfilled and OFF when filled with white colour:



MUTE OFF for input 5 – output 3 (send enabled)



MUTE ON for input 5 –output 3 (send disabled)

- **X-FOCUS MUTE:** not available when the WPTOUCH manages a carousel list of Presets. See **WPTOUCH configuration section** to operate with a **carousel of inputs**

- **GPO:** activation/deactivation of one of the MIMO88's GPO relays. In the WPTOUCH LCD, an asterisk appears when the function is activated and disappears when the function is deactivated (by successively pressing T1):

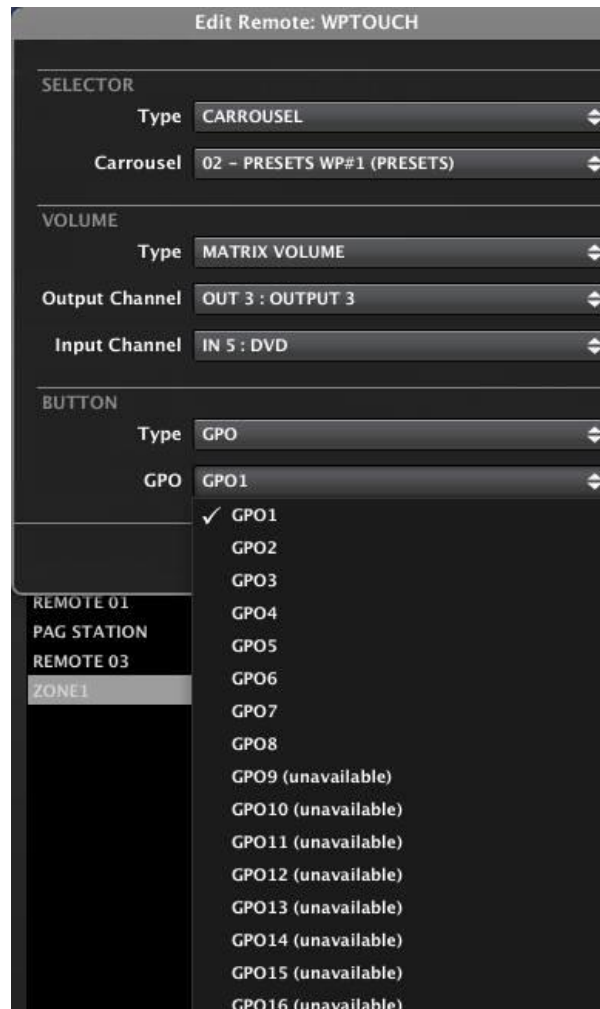

- **PRESET:** to load one of the Presets in the MIMO88 memory. In the WPTOUCH LCD, an asterisk appears when the function is activated and disappears when the function is deactivated (by successively pressing T1):

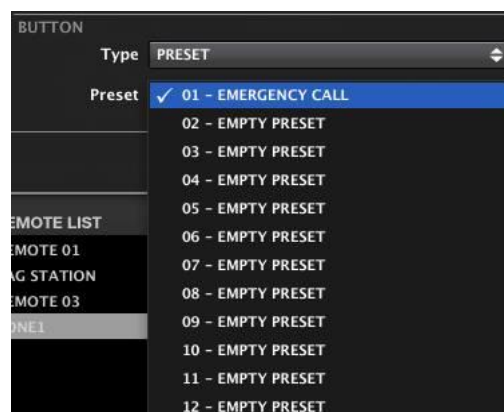

9.1.10.1.2. Configuring the WPTOUCH for operating with a carousel of inputs

A carousel list of inputs allows you to select which input will feed a particular output from a WPTOUCH acting as a selector of music sources for a destination zone (input selector for the matrix outputs). There may be up to 16 WPTOUCH units in one MIMO88 system (8x8 or 16x16), each one with the ability to select the audio content for the zone it is assigned to. See **Carousel lists for MIMO88** section for more information about the creation of carousel lists.

Selecting CAROUSEL in the SELECTOR function opens a menu to select the desired carousel list. Selecting a carousel list of inputs opens a new menu that lets you decide which system output will be linked to the input selection or in other words what destination zone (output) is controlled by this WPTOUCH unit:

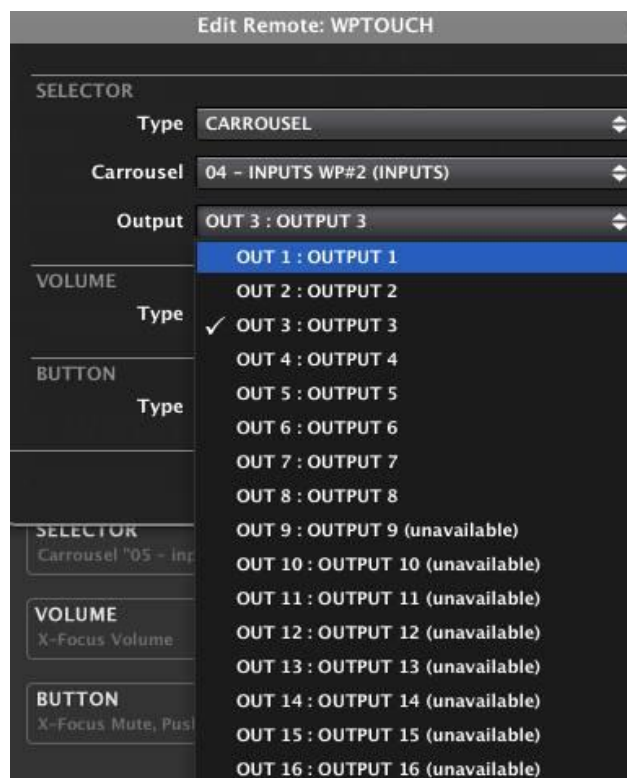

In the example we have selected a carousel list of inputs (called INPUTS WP#2) to enable input selection in this list for Output 3. This WPTOUCH unit will then behave as a sound source selector for the Zone 3 of the system.

After selecting a carousel list of inputs for the Selection mode of a WPTOUCH, you can make the selection from the WPTOUCH unit as follows:

NORMAL MODE:

- pressing T2 switches to the Selection mode (the triangular icon to the right of the LCD screen moves up to the upper row)
- with the wheel, select one of the inputs contained in the carousel list
- pressing T2 again confirms the selection, the matrix is set to route the selected input to the assigned output and the triangular icon returns on the bottom row (back in Volume Mode)

SIMPLE MODE:

- A short press of T1 key enters into **Selection mode**, where the control wheel rotation switches among the available audio inputs in the defined carousel list, with immediate changes and no need for confirmation by a new key press. A timeout of 3 seconds with no panel's gesturing, or a T2 key press will bring the panel back to the default **Volume mode**

The following configuration function (VOLUME) lets you select which volume the WPTOUCH wheel controls in the other mode, the **Volume mode** (default mode).

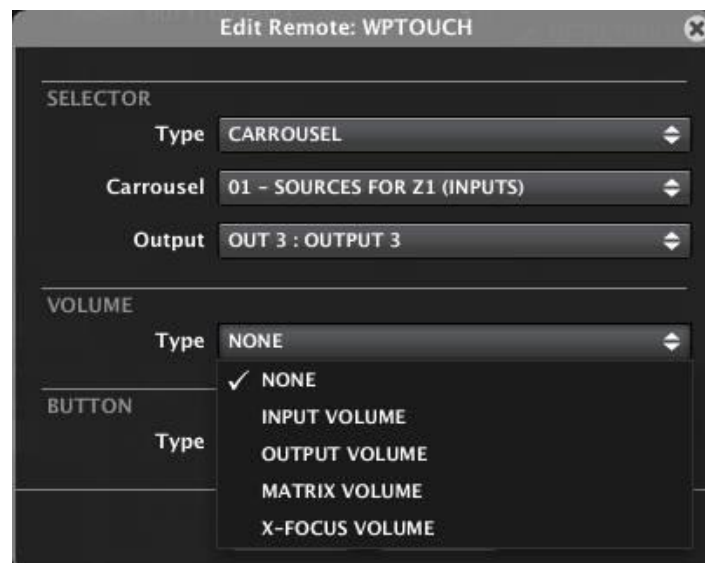

The available options for the VOLUME function are:

- **NONE:** Volume mode disabled
- **INPUT VOLUME:** any input of the MIMO88 unit:

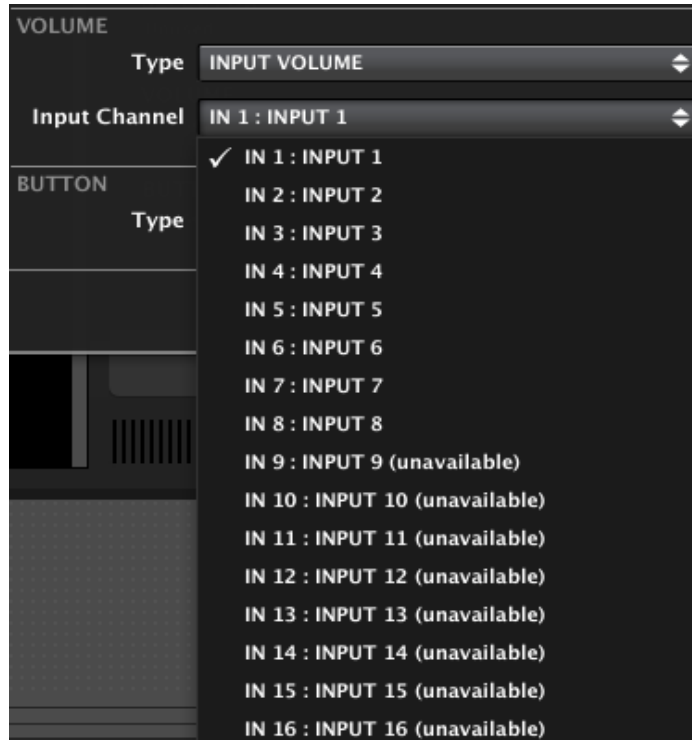

- **OUTPUT VOLUME:** any output of the MIMO88 unit:

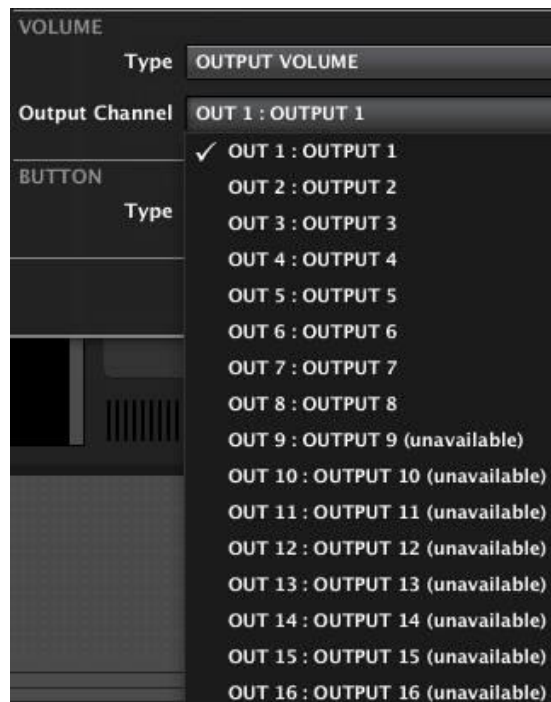

- **MATRIX VOLUME:** any crossing point between an input and an output of the matrix (in this example the crossing point between input 5 and output 3, or amount of signal sent from input 5 to output 3, represented in the matrix by the control knob of the intersection):

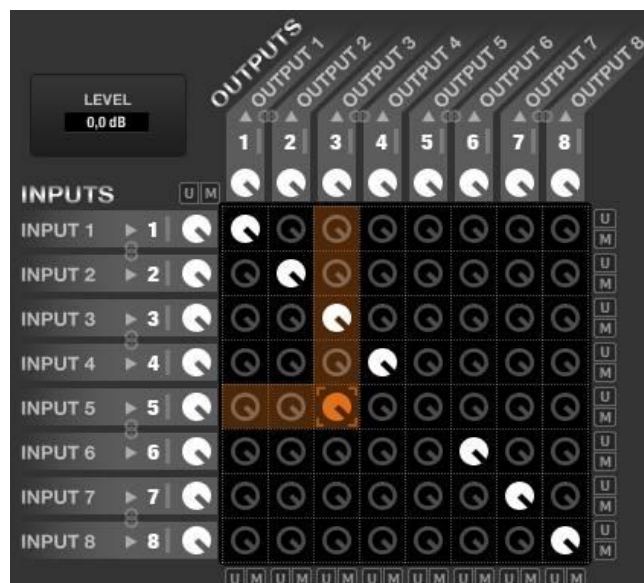
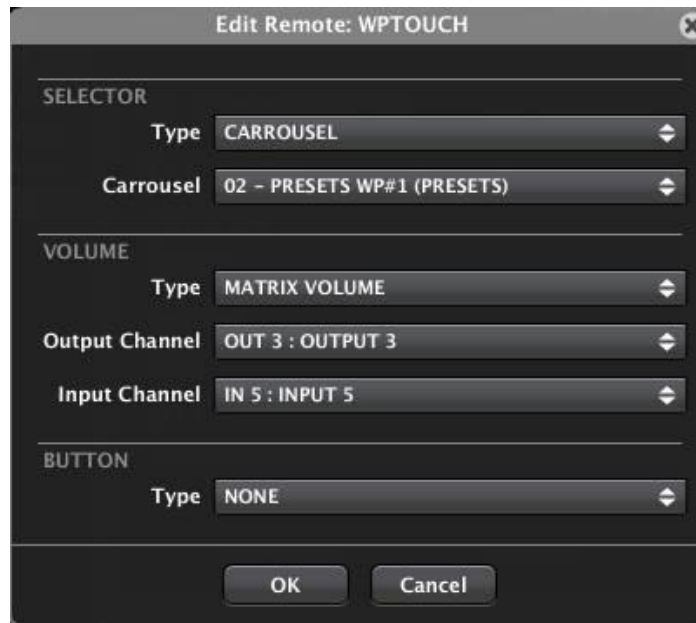

Volume Control selected in the previous example (in orange)

- **X-FOCUS VOLUME:** X-FOCUS (“Cross-Focus”) means the active crossing point in a carousel list of sound sources (inputs) for the assigned output. It is selected by programming the WPTOUCH unit. In other words, when a WPTOUCH is programmed for its Selection mode to choose an input in a carousel list, the X-Focus is the selection made at a given time, i.e. the input selected as audio content for the assigned output.

So, if you select the X-FOCUS VOLUME for the VOLUME function and have a look at what happens in the matrix, the WPTOUCH always operate the rotary volume control located at the intersection of the selected input and assigned output.

Example: let's create a carousel list of sound sources, or matrix inputs (see [Carousel lists for MIMO88 section](#)) including inputs 1. CD, 2. RADIO and 5. DVD, and let's assign a WPTOUCH managing the output 7 of the matrix:

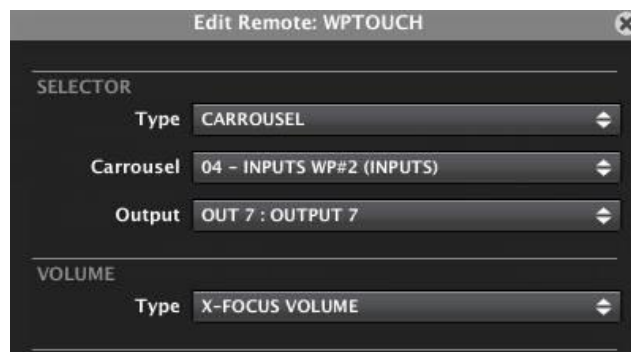

In "Selection" mode, you can cyclically select which input (1, 2 or 5) will be sent to output 7. Once one of them is selected, the wheel controls in Volume mode the crossing point of the selected input (1, 2 or 5) and output 7: the amount of signal sent from the selected input to output 7. If the selection changes, the volume wheel controls the new input/output crossing point selected.

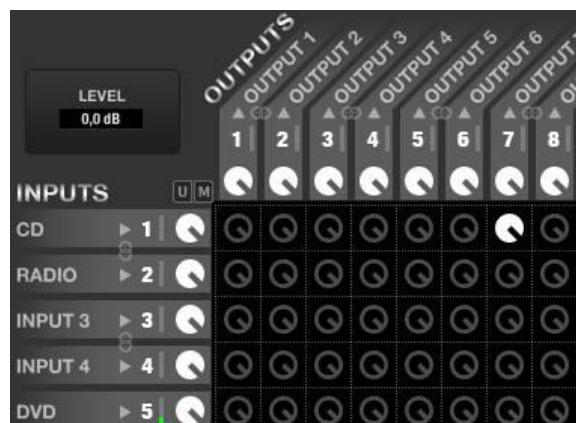

Input 1 (CD) selected as sound source for output 7. In X-Focus mode the volume control operates the crossing point between input 1 and output 7 (filled in white in the picture)

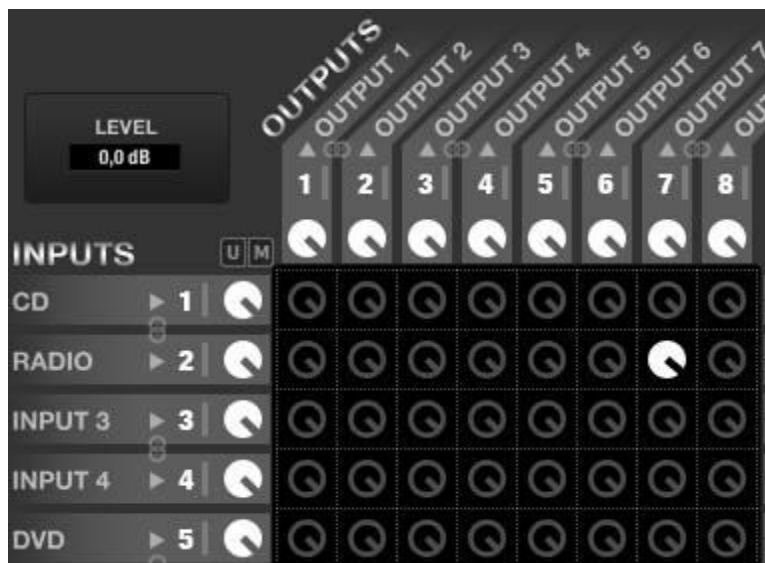

Input 2 (RADIO) selected as sound source for output 7. In X-Focus mode the volume control operates the crossing point between input 2 and output 7 (filled in white in the picture)

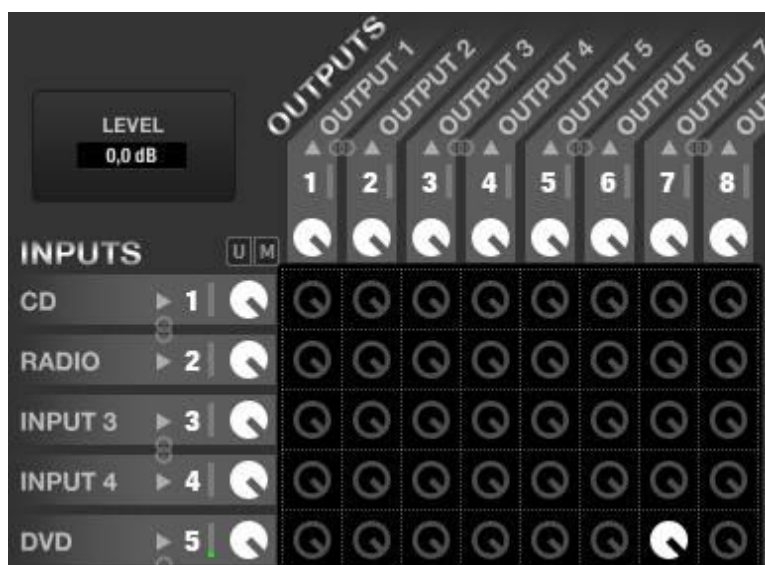

Input 5 (DVD) selected as sound source for output 7. In X-Focus mode the volume control operates the crossing point between input 5 and output 7 (filled in white in the picture)

The following configuration function (BUTTON) selects the function assigned to the T1 key of the WPTOUCH (not available for WPTOUCH **SIMPLE mode**).

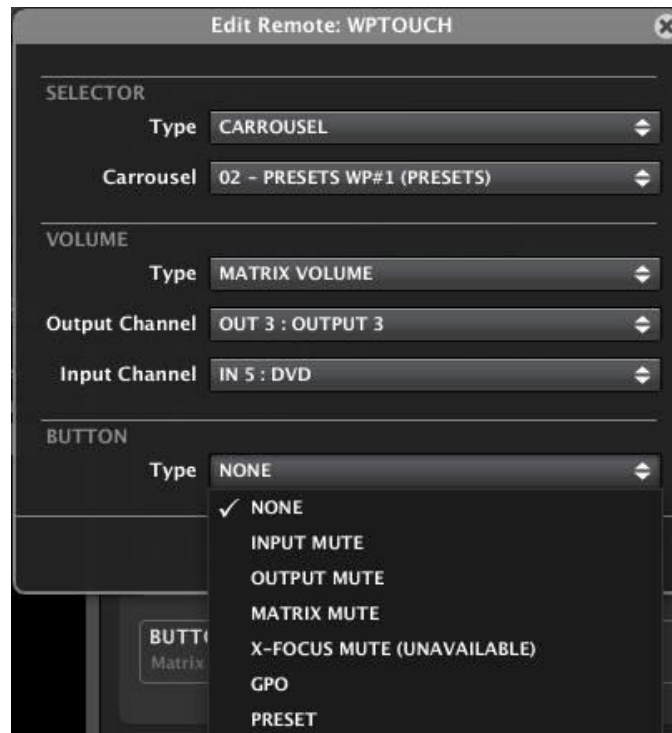

The available options for the BUTTON function are:

- **NONE**: T1 key disabled
- **INPUT MUTE**: mutes any input of the MIMO88 unit:

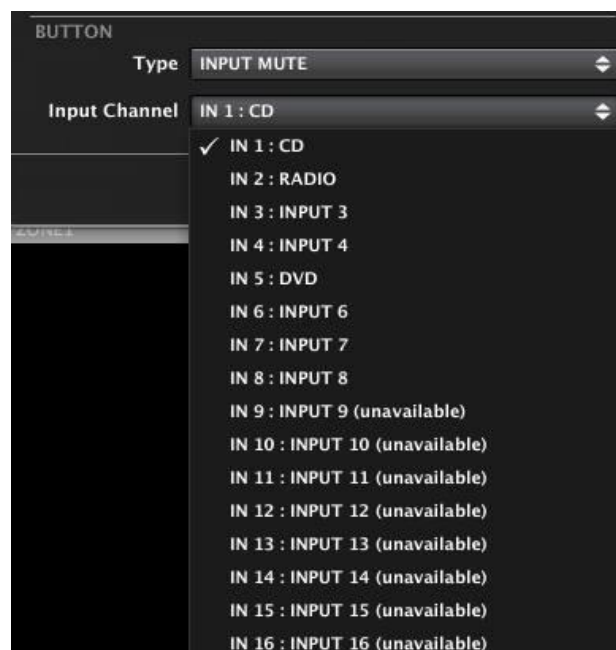

- **OUTPUT MUTE:** mutes any output of the MIMO88 unit:

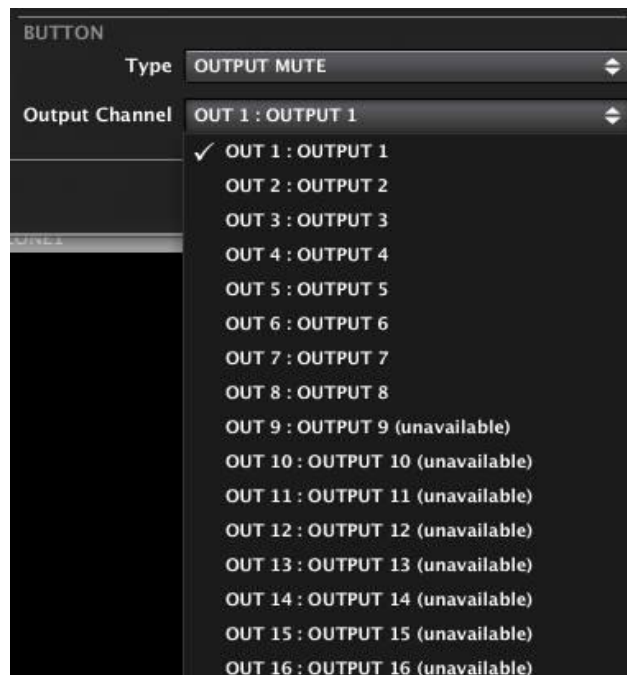

- **MATRIX MUTE:** mutes any crossing point between an input and an output of the matrix (in this example the crossing point between input 5 and output 3, or signal sent from input 5 to output 3, represented in the matrix by the control knob of the intersection: MUTE is ON when unfilled and OFF when filled with white colour:

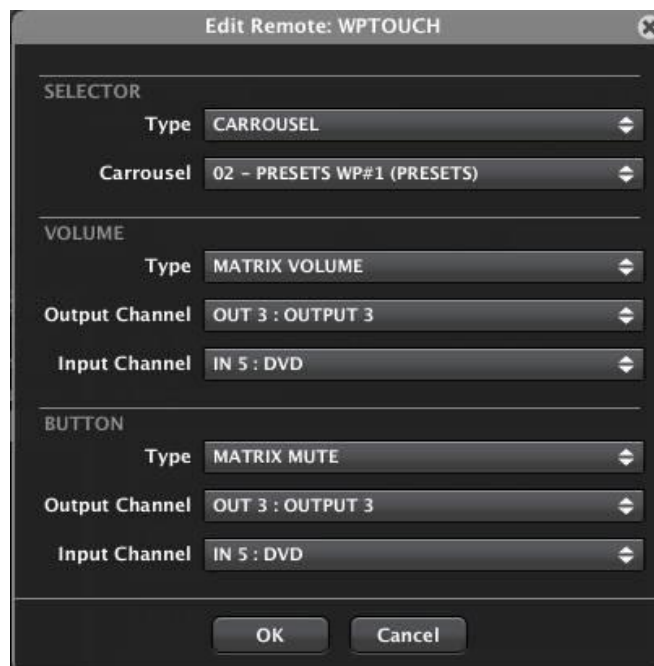

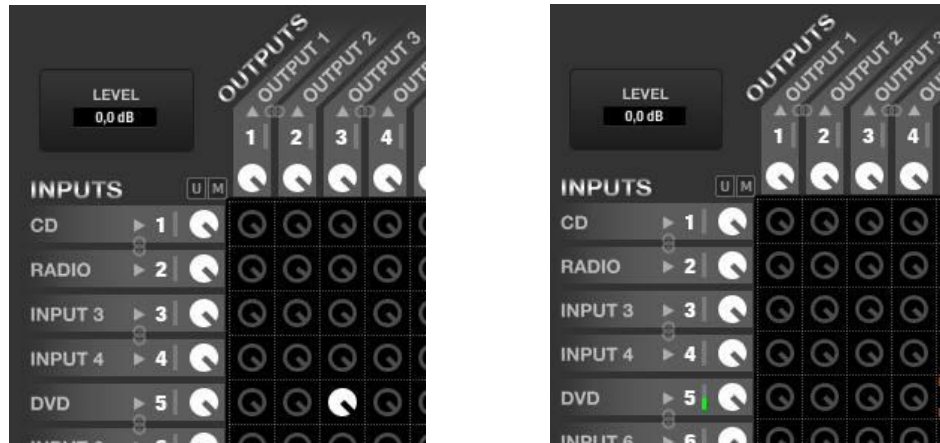

MUTE OFF for input 5 – output 3 (send enabled) MUTE ON for input 5 –output 3 (send disabled)

- **X-FOCUS MUTE:** similar to X-FOCUS VOLUME, but in this case the T1 key behaves like a mute remote control for X-Focus point, i.e. the point of intersection between the selected input and assigned output.
- **GPO:** activation/deactivation of one of the MIMO88's GPO relays. In the WPTOUCH LCD, an asterisk appears when the function is activated and disappears when the function is deactivated (by successively pressing T1):

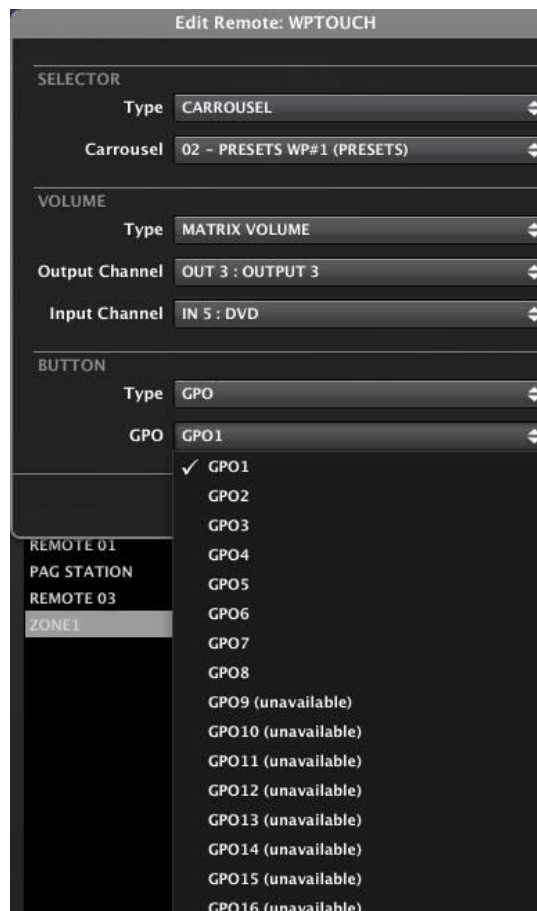

- **PRESET:** to load one of the Presets in the MIMO88 memory. In the WPTOUCH LCD, an asterisk appears when the function is activated and disappears when the function is deactivated (by successively pressing T1):

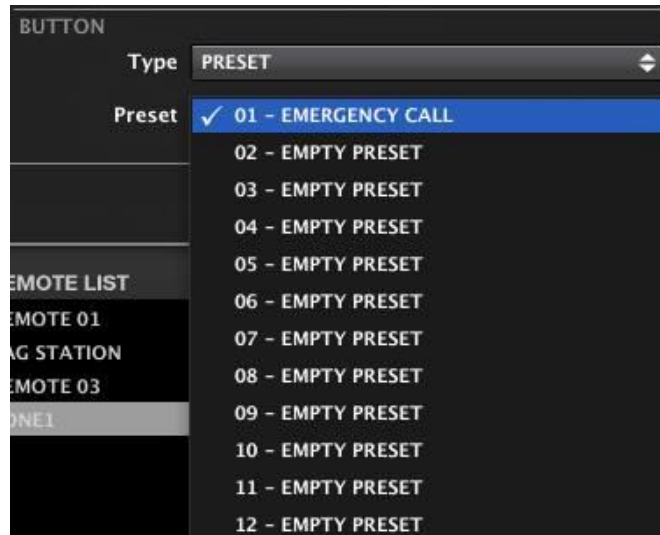

9.1.10.1.3. WPTOUCH MULTI devices

There is an additional working mode for a WPTOUCH unit, named WPTOUCH MULTI, which really behaves as a multi-zone controller. Under this working mode, a WPTOUCH hardware unit it will have a customized “remotes carousel list” including some single WPTOUCH units in the project, being those ones real (hardware) or virtual (just existing in the project, no hardware linked). The WPTOUCH MULTI can select any of those WPTOUCH units in its own carousel list to impersonate it, take its role, automatically behaving as a clone of a WPTOUCH single unit. This way a WPTOUCH hardware unit, programmed as a WPTOUCH MULTI, can be flexible and take the control of any zone, as well as being a preset recaller.

At the time you add a new WPTOUCH unit to your MIMO device, you can decide that it will work as a WPTOUCH MULTI unit:



And, adding more WPTOUCH units to your project, you will end up with a list of them, similar to this one:



Some of the above WPTOUCH units will be linked to real hardware WPTOUCH devices, and some others will just be virtual (software) ones, with no hardware impersonation. But all of them will be programmed individually, as single zone controls, with sources selection, or as presets selectors.

The WPTOUCH MULTI units, which do have a real hardware WPTOUCH partner, will be programmed just adding any of the previous WPTOUCH single units to a list. This list contains, then, the carousel of possible “roles” that a WPTOUCH MULTI can take when entering into its REMOTE SELECTION mode:



... double click on the desired items under the “Select WPTOUCH” options until the WPTOUCH list is completed as desired, and modify the position of each remote in the list, as this will be the order they’ll appear in the WPTOUCH MULTI LCD display, as a carousel list:



To get further information about WPTOUCH multi working mode, and how to use them once programmed, please refer to the document “**WPTOUCH MULTI user guide 201113.pdf**”, included in EclerNet Manager Software zip packs, available at www.ecler.com.

9.1.10.2. Configuring an eMPAGE or MPAGE16-type remote control

The MPAGE16 is a console or desktop digital station for sending voice messages in real time ("paging"). It features a gooseneck microphone and 16 keys for selecting destination zones (1 to 16), 1 selection key for all zones (ALL), a CLEAR key to cancel the last selection made and an activation key for paging (PAGE). It also has two soft keys (F1 and F2) operating a mute function, a GPO or a Preset recall. All keys are touch-sensitive and associated with a status LED.



Note: the eMPAGE unit is the substitute console for the MPAGE16 –JAN 2019 onwards-, a paging console with mechanical selection keys and electronic ink display to show the destination zones labels.

The programming of a paging console connected to a MIMO88 follows the same procedure, no matter if using an MPAGE16 or eMPAGE hardware unit.



The configuration of an MPAGE16 or eMPAGE console connected to the MIMO88 is very simple:

- First you must include a MPAGE16 / eMPAGE unit in the REMOTE LIST. See [MIMO88 REMOTES section](#).
- Selecting the desired MPAGE16 / eMPAGE unit in the REMOTE LIST displays its detailed configuration window:



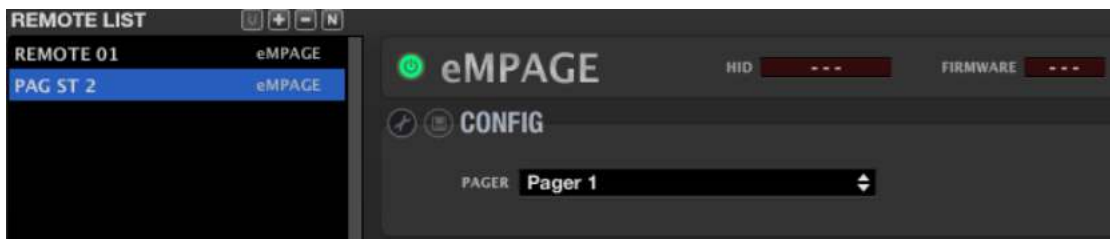

If the paging console is an eMPAGE model, the above picture will look similar to the following:



In its upper part, the window includes:

- **Enable/Disable Remote button:** to enable (lit in green) or disable each MPAGE16 / eMPAGE unit connected to the MIMO88. The state (enabled or disabled) of all remote controls is stored in a system Preset when you save it, so that you can manage at any given time which remote controls are enabled or not by recalling each Preset (e.g. when loading a Preset for asking to evacuate a building with a pre-recorded message, all remote controls of the installation are disabled to avoid user interferences in such special scenario in which the evacuation message prevails on the rest of the audio signals...).
- **HID indicator:** hardware ID (assigned at the factory, unique to each unit and not editable by the user)
- **Firmware indicator:** unit's firmware version

Now comes the MPAGE16 / eMPAGE configuration area:

- The  icon (Change Configuration) is not usable with an MPAGE16 / eMPAGE unit (but it is for the WPTOUCH for example)
- The  (Save Configuration in Remote) icon stores the MPAGE16 / eMPAGE device configuration

Below appears the drop-down menu for the only setting option of MPAGE16 / eMPAGE unit: the PAGER module that will be assigned:

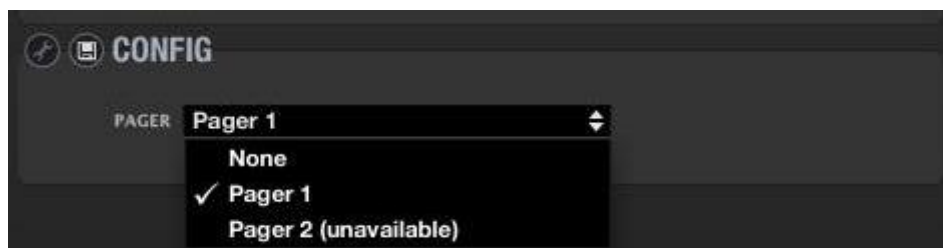

Each MIMO88 unit has a maximum of four DUCKER or PAGER software modules, each of which can be assigned to a hardware MPAGE16 / eMPAGE unit.

See **MIMO88 PAGERS/DUCKERS** section to know how these modules operate and how destination zones are enabled or disabled for MPAGE16 / eMPAGE units, etc.



Details of the PAGERS/DUCKERS section from which you configure the operation of an MPAGE16 / eMPAGE unit connected to the system

All MPAGE16 / eMPAGE keys are dedicated to the paging function, except two of them: F1 and F2 that are programmable function keys. See [MIMO88 EVENTS](#) section to know how to program them for operating a mute function, a GPO or a Preset recall.

Note: The configuration of a digital remote control as MPAGE16 / eMPAGE console or WPTOUCH wall panel depends on a Project but not on a Preset (you can't save distinct WPTOUCH settings in different Presets within the same Project).

9.1.10.3. Configuring an ANALOG-type remote control

The third type of remote controls compatible with MIMO88 is analogue such as WPMVOL-SR / WPAVOL-SR (wall panel with knobs performing as volume control and sound source selector). The **INPUT** source selector has 5 possible positions (OFF, 1, 2, 3 and 4). The **LEVEL** volume control is continuous from 0 to 100%.



This type of control is connected to the MIMO88 unit via its GPI ports, not via the digital bus. A GPI port is required for the volume control and another one for the source selector. Additionally, you can connect an external switch (not included in the WPMVOL-SR / WPAVOL-SR) to a third GPI to perform the X-FOCUS MUTE function (muting the selected sound source).

The settings for this kind of analogue control are performed as follows:

To configure a WPMVOL-SR / WPAVOL-SR type analogue control, you must first include an ANALOG unit in the REMOTE LIST. See [MIMO88 REMOTES section](#)



Note: analogue controls are passive and therefore not automatically detected by the application, contrary to what happens with the digital WPTOUCH and MPAGE16 / eMPAGE.



Once you add such a control, it will be included in the REMOTE LIST. Selecting it opens the configuration window:



In its upper part, the window includes:

- **Enable/Disable Remote button:** to enable (lit in green) or disable each WPmVOL-SR / WPaVOL-SR unit connected to the MIMO88. The state (enabled or disabled) of all remote controls is stored in a system Preset when you save it, so that you can manage at any given time which remote controls are enabled or not by recalling each Preset (e.g. when loading a Preset for asking to evacuate a building with a pre-recorded message, all remote controls of the installation are disabled to avoid user interferences in such special scenario in which the evacuation message prevails on the rest of the audio signals...).
- **HID indicator:** N/A for analogue controls
- **Firmware indicator:** N/A for analogue controls

Now comes the configuration area:

-  icon (Change Configuration): to change the unit configuration
-  icon (Save Configuration in Remote): N/A for analogue controls

Clicking the  icon displays the WPmVOL-SR / WPaVOL-SR configuration window:

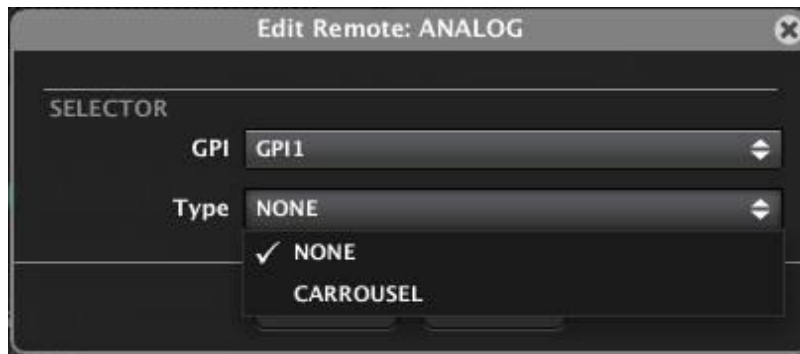

The first parameter to set is the source selection or SELECTOR:

- **GPI:** GPI port that is connected to the INPUT discrete potentiometer of the WPmVOL-SR / WPaVOL-SR unit
- **Type:** select CARROUSEL to allow sound sources or even Presets to be selected. After selection, new options are displayed:

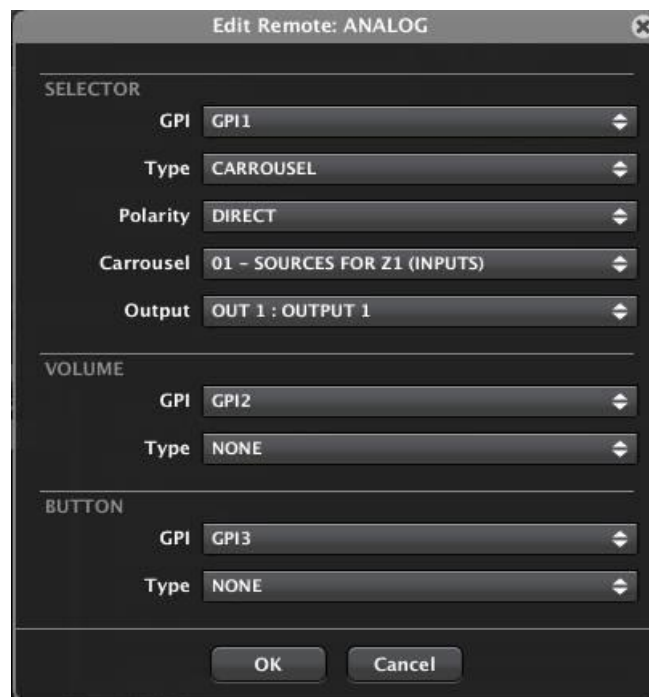

The new available options for the SELECTOR function are:

- **Polarity (DIRECT/INVERSE):** determines how the received signal is interpreted in the GPI (0 to 10 VDC): 0 VDC as minimum and 10 VDC as maximum or vice versa. Each position of the WPmVOL-SR / WPaVOL-SR **INPUT** control (OFF, 1, 2, 3 or 4) provides a voltage from 0 to 10 VDC to its GPI port.
- **Carousel:** carousel list selected for the WPmVOL-SR / WPaVOL-SR control; it must have been previously created. A carousel list contains the available options for selecting either the input sound sources (Inputs) or the MIMO88 Presets from a WPmVOL-SR / WPaVOL-SR unit with its **INPUT** control. In this case the carousel list may include up to 5 inputs (musical sources) matching the 5 positions of the WPmVOL-SR / WPaVOL-SR **INPUT** control. If you select a carousel list of Presets, it may also contain a maximum of 5 Presets. See [Carousel lists for MIMO88](#) for more information about the creation of carousel lists.
- If the selected carousel list is for inputs (sound sources), a new drop-down menu appears to select the destination output for this selection (destination zone area linked to the selected input in each case, or destination zone controlled by the WPmVOL-SR / WPaVOL-SR unit):

In
of

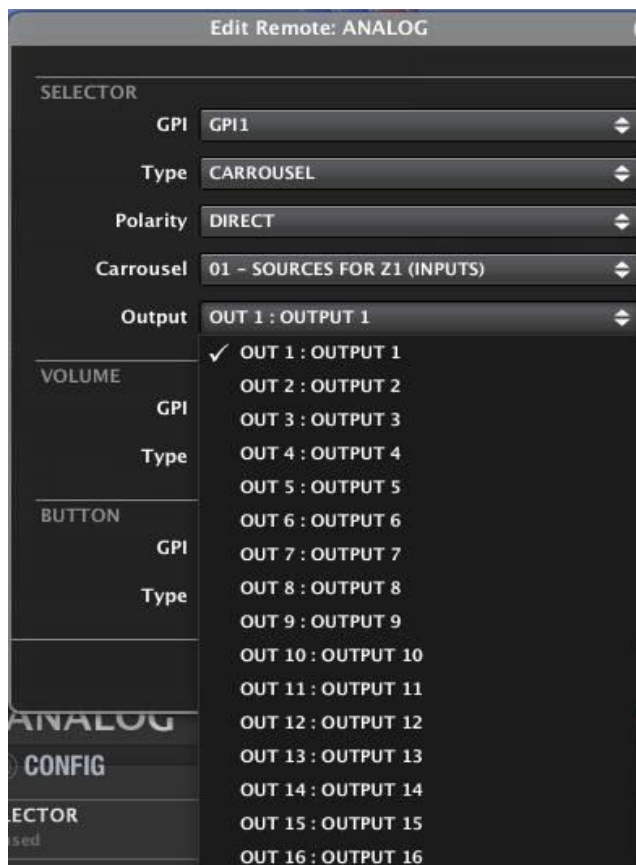

the example we have selected a carousel list inputs (called SOURCES FOR Z1) to enable the selection of an input from this list for output 1. This WPmVOL-SR / WPaVOL-SR unit will then behave as a sound source selector for the Zone 1 of the system.

The options for the VOLUME function are:

- **GPI:** GPI port that is connected to the **LEVEL** control of the WPmVOL-SR / WPaVOL-SR unit
- **Type:**
 - **NONE:** no volume function assigned
 - **X-FOCUS VOLUME:** the **LEVEL** control is associated with the volume of the crossover point between the input currently selected by the **INPUT** control and assigned output (destination zone)
- **Polarity (DIRECT/INVERSE):** determines how the received signal is interpreted in the GPI (0 to 10 VDC): 0 VDC as maximum volume and 10 VDC as minimum volume or vice versa.



Additionally, you can add an external mechanical switch or button (not included in the WPmVOL-SR / WPaVOL-SR panel) to control the X-FOCUS MUTE function (to mute the selection made with the **INPUT** control in the used carousel list):



- **GPI:** GPI port that it is connected to the additional hardware button or switch
- **Type:**
 - **NONE:** no MUTE function assigned
 - **X-FOCUS MUTE:** the button or switch is associated with the MUTE function of the crossover point between the input currently selected by the **INPUT** control and assigned output (destination zone)

- Additional options when the X-FOCUS MUTE type is selected are:
 - **Polarity (DIRECT/INVERSE):** determines how the received signal is interpreted in the GPI (0 or 10 VDC): function is activated for 0 VDC and deactivated for 10 VDC or vice versa.
 - **Mode:** operating mode of the button or switch:
 - **PUSH:** one state when the key is pressed (closed contact) and the opposite state when the key is not pressed. The possible states are MUTE ON and MUTE OFF
 - **TOGGLE:** each push of the button toggles the state between MUTE ON and MUTE OFF.



9.1.11. Carousel lists for MIMO88

A **carousel list** is a set of selectable options for a remote control connected to a MIMO88 unit, such selection being "circular" (hence the name carousel).

We call circular selection the ability to scroll the various list options via an endless dial, from the first to the last, then indefinitely re-starting from the first in the list and so on, as long as you keep rotating the control in the same direction, either clockwise or counter-clockwise.

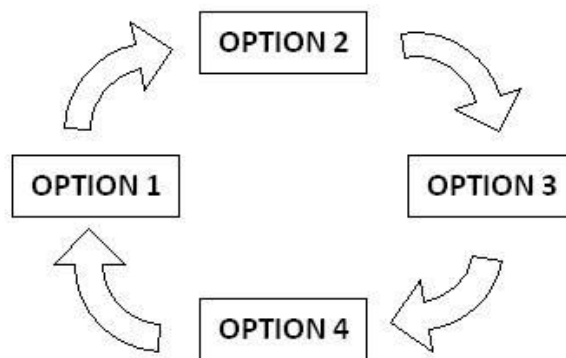

Example of circular list or carousel list with 4 available options

MIMO88 supports two types of carousel lists: for inputs and for Presets:

- **Carousel list of inputs:** contains a series of matrix audio inputs, so that a remote control can select one of them as a sound source sent to a particular audio output of the unit. In other words, in a zoned facility (input with several sound sources and multiple output zones) a remote control managing a particular zone of the facility can use a list of this type to select the audio content to be played in that zone
- **Carousel list of Presets:** contains a series of Presets stored in the unit, so that a remote control can select and recall one of them, instantly changing the configuration of the MIMO88 unit according to the parameters recorded in the Preset

Note: A WPTOUCH or WPmVOL-SR / WPaVOL-SR type remote control can operate a same Project with a **single carousel list** only, whether of **inputs or Presets**, in order to behave as source selector for a destination zone or as Preset selector to recall a Preset. A single control remote can never have both functions in a same Project, nor operate with several carousel lists. Carousel lists, on the other hand, are common to a single Project and are not related to Presets: lists and their contents are fixed and do not depend on the Preset that selected them.

Clicking the  icon located in the upper right corner of a MIMO88 detailed view opens the window for creating and editing carousel lists.

Note: as for other functions with a potential risk of structural changes in a Project, carousel list management is available in DESIGN mode only.

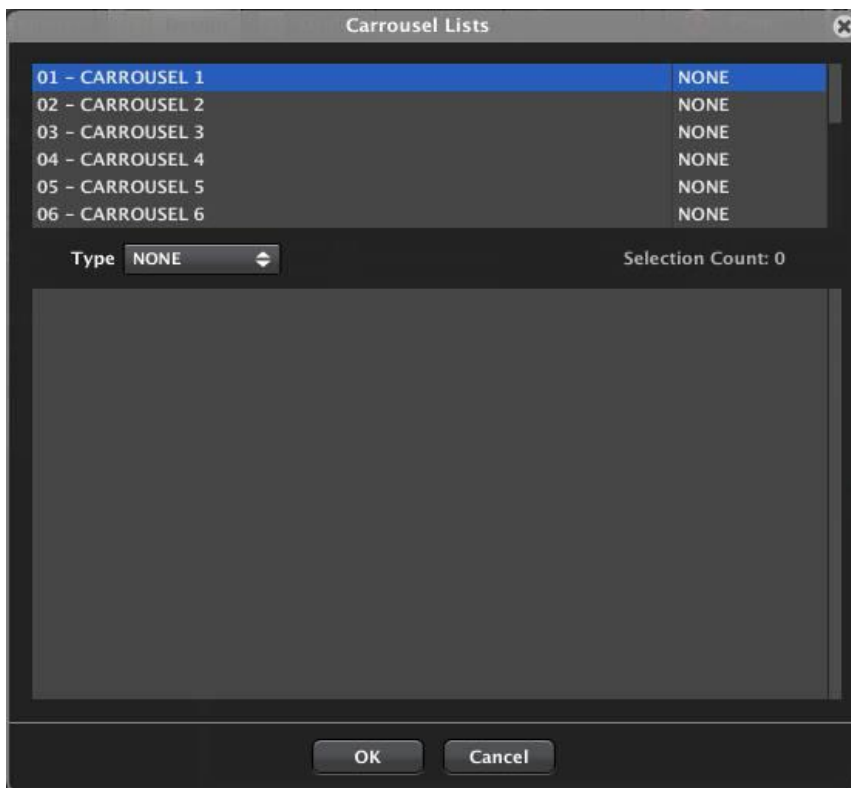

In the upper part of this window, there is a list of the 16 carousel lists that can be created in a Project.

To rename one of them, select it (right button -> Rename, or F2 key):

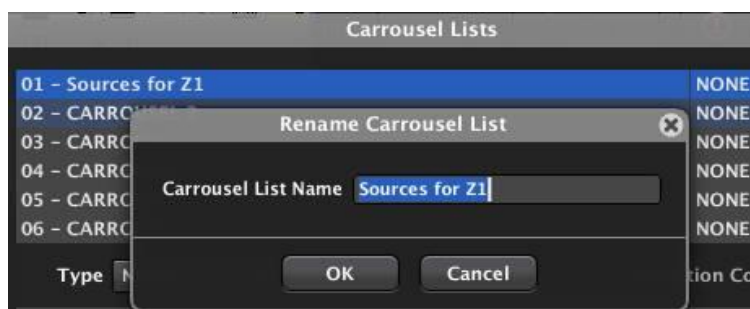

Then you must select the type of list (inputs or Presets):

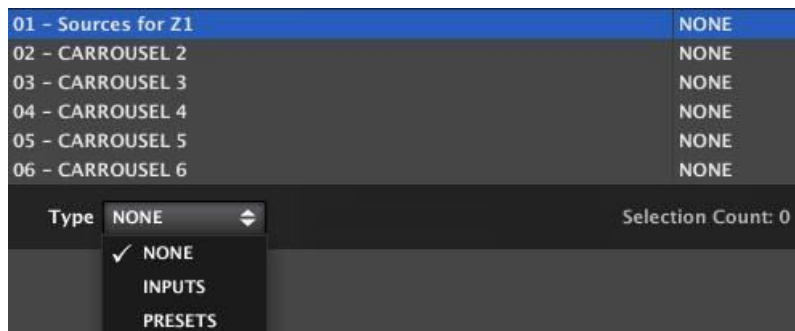

If you select an input list, the window looks like this:

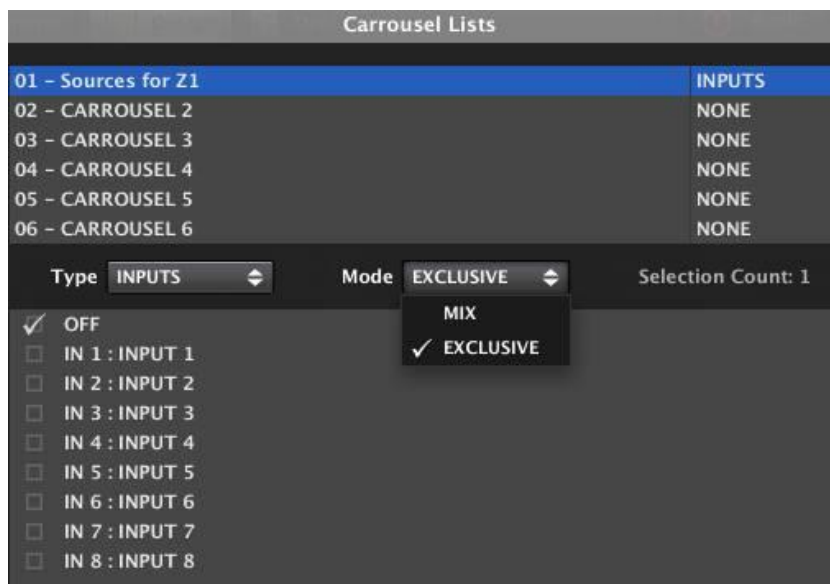

- **The list type** is displayed on the right: INPUTS or PRESETS
- **The drop-down Mode** menu allows you to choose between two operating modes for the input list:
 - **MIX**: when several inputs are successively selected in the list, they are mixed together and sent to the destination output. The remote control then behaves like a small mixer, rather than as a pure sound source selector (in X-Focus mode the volume control will adjust the relative level of each input in the mix)
 - **EXCLUSIVE**: only one input can be selected and routed to the destination output. Selecting an input in the list excludes the others: the other crossing points between list inputs and destination output have a MUTE ON status
- **Selection Count**: number of inputs in the list (the maximum is 16)

- **Input list for the unit:** its options are OFF (no = silence) and inputs 1 to 8 or 1 to 16, depending on whether it is a single MIMO88 (8x8) or a MASTER-SLAVE couple (16x16). To add or remove an input to/from the carousel list, click on the check box on its left:

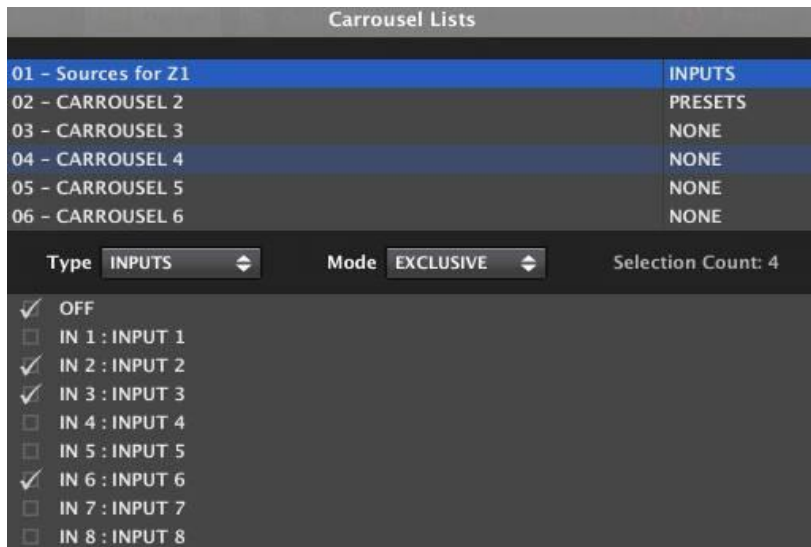

Example of carousel list containing the inputs OFF (silence), 2, 3 and 6

Once the changes are validated (OK key) the list will be configured and available for selection from one or more WPTOUCH or WPmVOL-SR / WPaVOL-SR remote controls.

If, on the contrary, you select a Presets list, the window looks like this:

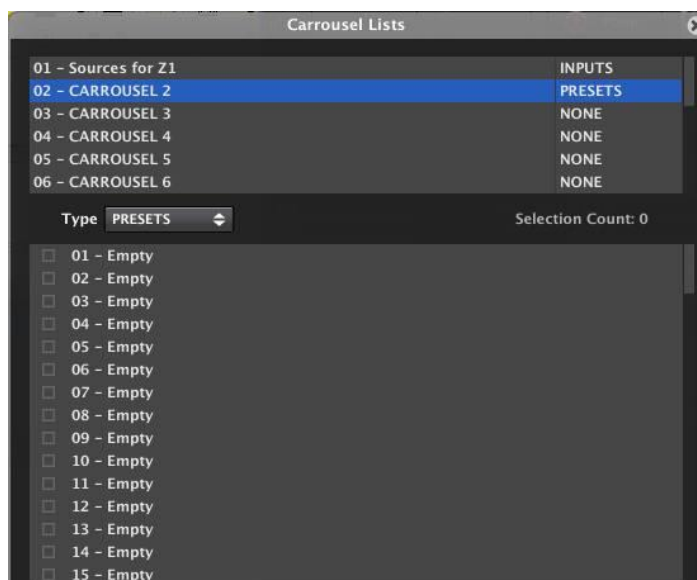

- **The list type** is displayed on the right: INPUTS or PRESETS (in this case PRESETS)
- **Selection Count:** number of Presets in the list (the maximum is 16)

- **Presets list for the unit:** contains the 99 Presets available in the MIMO88 (you have to scroll down the list to see them all). To add or remove a Preset to/from the carousel list, click on the check box on its left:

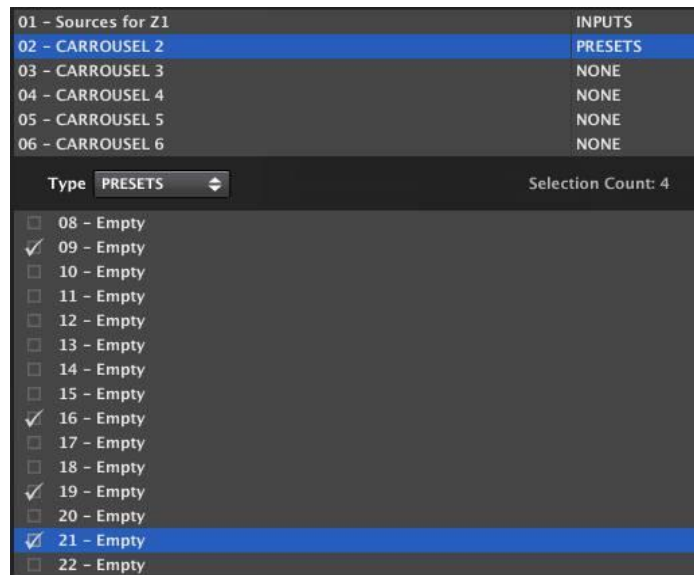

Example of carousel list containing the Presets 9, 16, 19 and 21

Once the changes are validated (OK key) the list will be configured and available for selection from one or more WPTOUCH or WPmVOL-SR / WPaVOL-SR remote controls.

9.1.12. MIMO88 EVENTS section

A MIMO88 event is a small program routine converting a series of input stimuli (GPI ports, WPTOUCH or MPAGE16 / eMPAGE panel keys, etc..) in an action which could affect the value of a parameter (volume control, mute control, etc..), load a Preset, enable or disable a GPO, etc.

Events can be of 5 types:

- **ANALOG:** the stimulus takes a set of values within a range and the target is a control also varying within a range. Example: a potentiometer connected to a GPI as a stimulus and the volume control of an output as the target
- **DIGITAL SIMPLE:** the stimulus can only take 2 values (1 or 0, open or closed, etc.) and the target as well. Example: a switch connected to a GPI as a stimulus and the mute control of an output as the target

- **DIGITAL COMPOUND:** as above, but with multiple stimuli: up to 4 individual digital stimuli combined using a Boolean logic gate (AND, OR, NAND, NOR, etc.). **Example:** two switches connected as stimuli to their respective GPIs triggering a Preset (target) when one of them is pressed (using for this an OR-type logic gate)
- **DIGITAL DELAY:** you can set a delay time between the stimulus detection and the destination triggering or event output, as well as a holding time of this activated status for the output (for example: 10 seconds after detecting an external contact closure connected to a GPI, a relay (GPO) status changes for 90 seconds, then returns to its previous state)
- **TIME SCHEDULER:** the stimulus input time is based on a calendar with date and time of onset, duration, days of the week it must be activated or not, repetition by time interval or number of repetitions and end date. The MIMO88 has an internal clock that allows the management of such events, even if not connected to a computer and synchronized with EclerNet Manager

Events programming is very simple, consisting of the following steps:

- Selecting the input stimulus (or stimuli) and behaviour settings
- Selecting how stimuli are combined (only for compound digital events)
- Selecting the event target (triggered function)

The maximum number of events for the MIMO88 is 64. Events are stored at the Project or device level, but not in the Presets. However, the state (enabled or disabled) for each event (configurable with "Event Enable" from the event editor window) is stored as part of the data stored in each Preset, so that recalling a Preset also restores the current combination of enabled and disabled events at the time of saving.

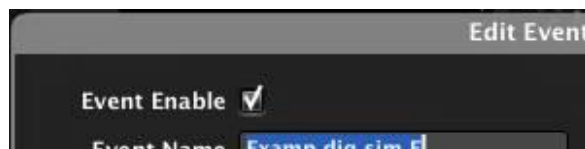

Events are manually created and edited from a dedicated control list. Additionally, some events are automatically created when you program a remote control from the REMOTES section, appearing in grey in the list of events as they can only be viewed but not edited.

Clicking on the  icon located in the upper right of the application displays the **Events list** in the bottom of the screen:



The list shows created events (manually or automatically) with a number of information fields:

- **#**: event number in the list
- **Event Name**: event name
- **Type**: event type (Analog, Digital (Simple) or Digital (Compound))
- **Source**: information about the stimuli selected for the event
- **Target**: information about the target of the event
- **Raw OUT Value**: event output value, monitored in real time

The events list can be deployed both in DESIGN and DEPLOY modes, but editing functions, new events creation, events deletion etc. are enabled in DESIGN mode only.

Right-clicking the list displays the following context menu:

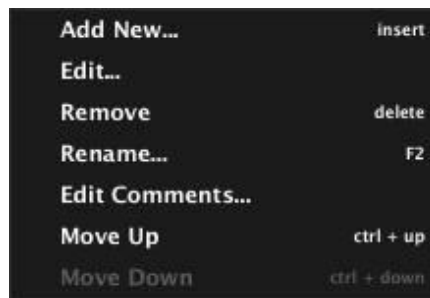

- **Add New:** to add a new event to the list
- **Edit:** to edit an existing event (the one currently selected in the list)
- **Remove:** to delete the selected event
- **Rename:** to rename the selected event
- **Edit Comments...:** to edit the comments text field for the selected event
- **Move Up:** the selected event moves up one position in the list
- **Move Down:** the selected event moves down one position in the list

Adding a new event opens the following configuration window which lets you assign a name to the new event and define its type (ANALOG/DIGITAL (SIMPLE)/DIGITAL (COMPOUND)/DIGITALDELAY/TIMER SCHEDULER):

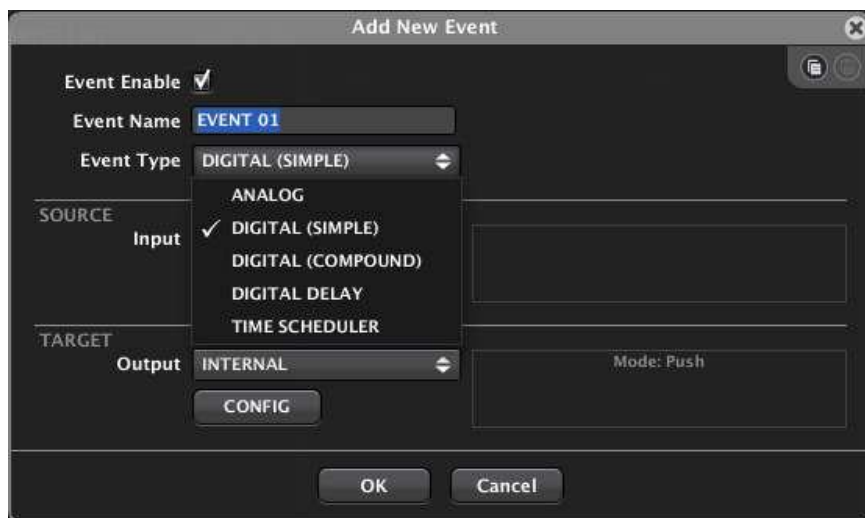

Note: to add a new event or to edit an existing one, you can perform copy and paste operations between a source event and a destination event, using the icons located at the top right corner of the edit window:

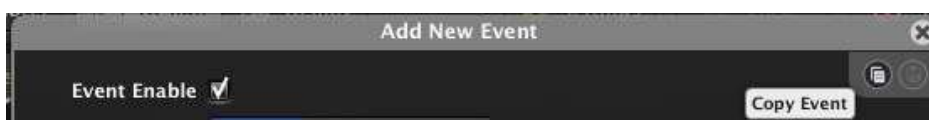

9.1.12.1. Analog events

If you select the ANALOG type for the new event, you must choose the stimulus associated with this trigger using the SOURCE selector:

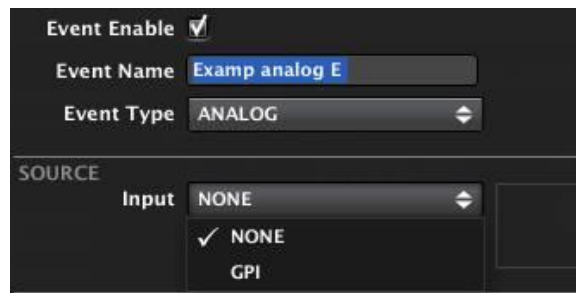

An analog event can be triggered by a GPI port. You need to indicate the GPI port the external device is connected to for operating as a stimulus (potentiometer, external DC power supply, etc.):

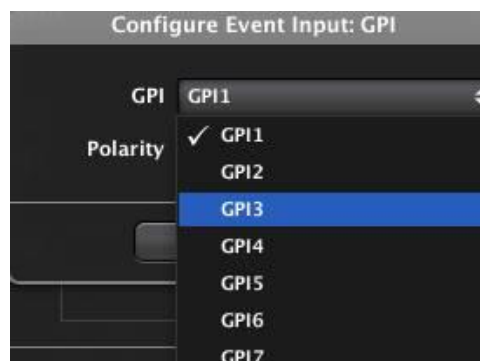

After that, you can define whether the GPI signal will be directly interpreted (0 VDC is considered as the minimum and 10 VDC as the maximum) or inverted (the opposite of the previous case). This setting allows a potentiometer to set a maximum volume in the fully CW position and a minimum volume in the fully CCW position, or vice versa.

Another possible trigger source for this type of event is a virtual control from an UCP control panel (see section: [User Control Panels \(U.C.P.\)](#))

The next step is to define the event target with the TARGET selector:



Possible targets are:

- **INTERNAL:** the event output is "internal", so it may be used as input or stimulus for another event to concatenate them
- **INPUT VOLUME:** volume control of an input to be selected:



- **OUTPUT VOLUME:** volume control of an output to be selected
- **MATRIX VOLUME:** volume control of a particular crossing point of the matrix. In this case you must select the input and output which define the intersection:



Selection of the crossing point between input 6 and output 4

9.1.12.2. Simple digital events

If you select the DIGITAL (SIMPLE) type for the new event, you must choose the stimulus associated with this trigger using the SOURCE selector:

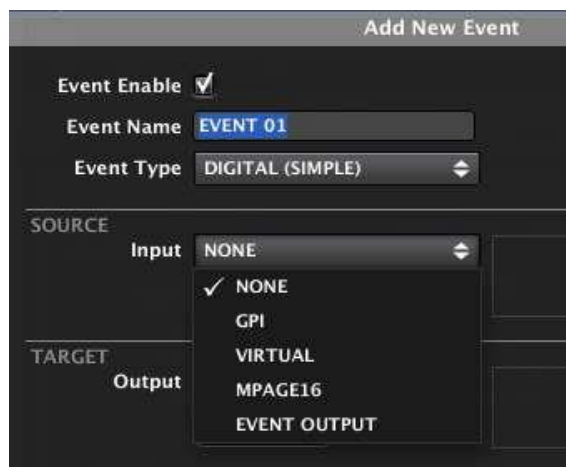

A simple digital event consists of a single stimulus, which may be a GPI port input, a virtual control from an UCP control panel (see **User Control Panels (U.C.P.)**), a programmable key of MPAGE16 / eMPAGE station (F1 and F2 keys), PAGE key or PAGE function activated for a zone 1 to 16 (ie selected zone + PAGE key pressed) or the output of another event previously created, thus concatenating two events.

NOTE: From EclerNet Manager v6 onward, the DUCKER priority module has been introduced as a new input option for digital events in the MIMO4040CDN / MIMO7272DN. In this way it is possible to activate a digital event using audio signal detection: the audio signal that exceeds the threshold level set in a DUCKER module's parameters, will activate a digital event... This offers very powerful options of control and automation.

If GPI is selected, you need to specify the GPI port and the DIRECT/REVERSE polarity:

- **DIRECT:** for rising edge-triggering, from 0VDC to 10VDC
- **REVERSE:** for falling edge-triggering, from 10VDC to 0VDC

With this setting, a switch can for example toggle a MUTE control when pressed (contact closed) or vice versa.

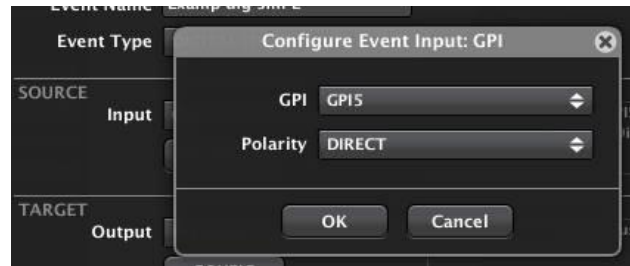

If a UCP virtual control is selected as stimulus, we need to specify which one among the 64 that are available and how the stimulus is interpreted, DIRECT / REVERSE (when you press or release), as in the previous case:

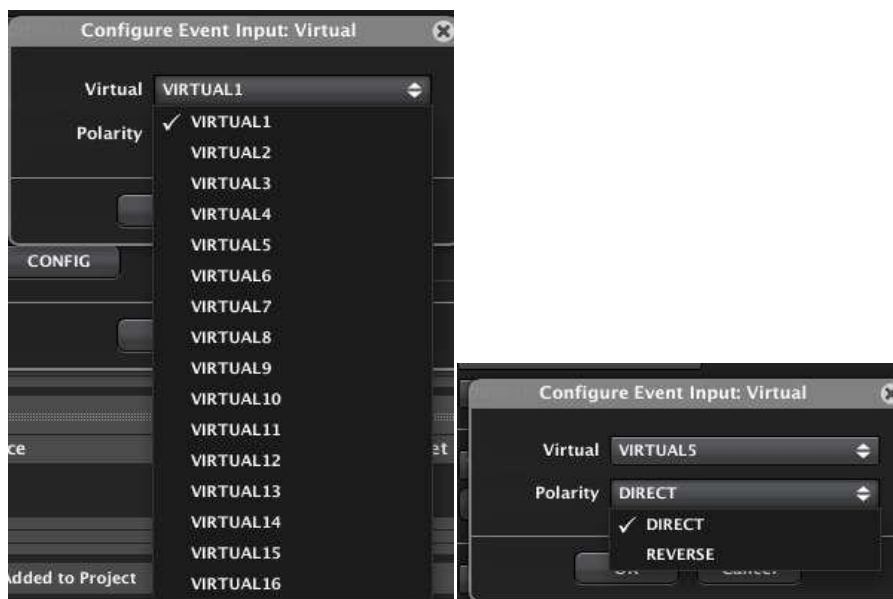

If MPAGE16 / eMPAGE is selected, you need to specify the MPAGE16 / eMPAGE button in question (among those previously included in the Project), and the DIRECT/REVERSE polarity (when you

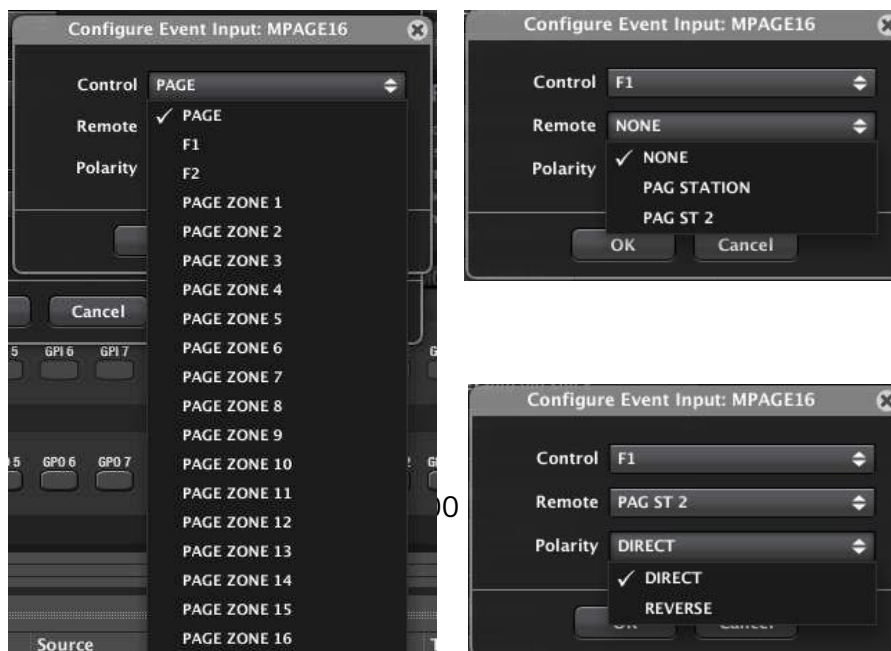

press or release) as above.

If EVENT OUTPUT is selected, you need to specify the event, and the DIRECT/REVERSE polarity as above:



If DUCKER is selected (in MIMO4040CDN y MIMO7272DN), you need to specify the DUCKER module that will trigger the event, as well as its DIRECT/REVERSE polarity:

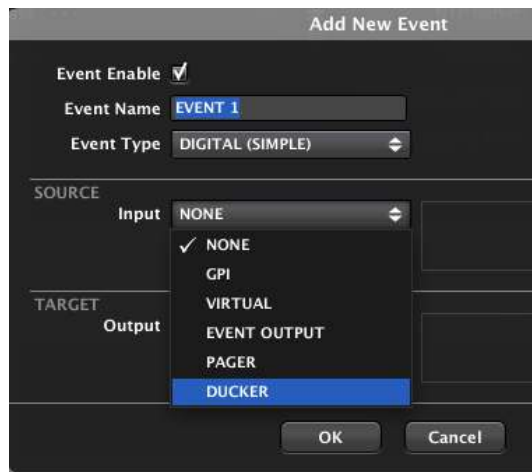

The next step is to define the event target with the TARGET selector:

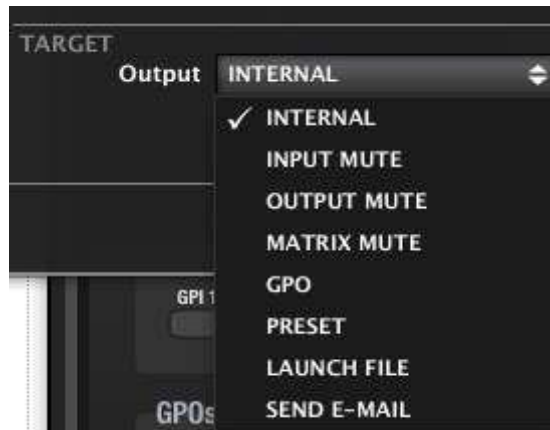

Possible targets are:

- **INTERNAL**: the event output is "internal", so it may be used as input or stimulus for another event to concatenate them
- **INPUT MUTE**: to MUTE an input; you need to select this input and its behaviour mode:
 - **PUSH**: "unlatch" mode; MUTE control follows the stimulus (for example, MUTE ON as long as the switch is pressed)
 - **TOGGLE**: "latch" mode; successive presses toggle the MUTE on/off



- **OUTPUT MUTE**: to MUTE an output; you need to select this output and its behaviour mode:
 - **PUSH**: "unlatch" mode; MUTE control follows the stimulus (for example, MUTE ON as long as the switch is pressed)
 - **TOGGLE**: "latch" mode; successive presses toggle the MUTE on/off



- **MATRIX MUTE:** to MUTE a matrix crossing point; you need to select this crossing point and its behaviour mode:
 - **PUSH:** "unlatch" mode; MUTE control follows the stimulus (for example, MUTE ON as long as the switch is pressed)
 - **TOGGLE:** "latch" mode; successive presses toggle the MUTE on/off



- **GPO:** to enable/disable a GPO port of the MIMO88 unit; you need to select this port and its behaviour mode:
 - **PUSH:** "unlatch" mode; the GPO follows the stimulus (for example, GPO ON as long as the switch is pressed)
 - **TOGGLE:** "latch" mode; successive presses toggle the GPO on/off



- **PRESET:** Preset recall from the MIMO88 memory by selection in the list of available Presets:

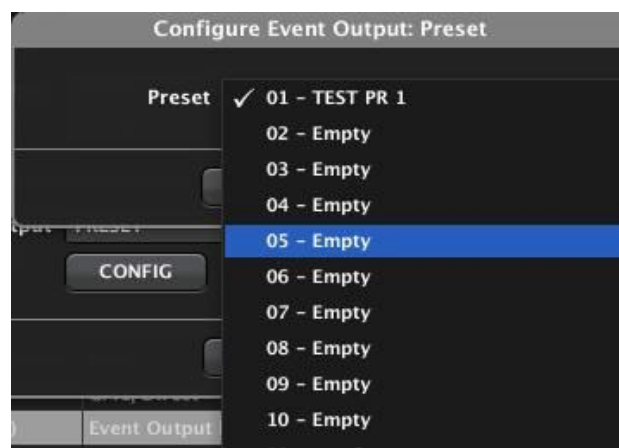

Note: It is important to understand that a Preset is restored only when there is a rising edge as a stimulus. In the case of a simple digital event, if it is designed to recall a Preset, you must be sure that there will be a rising edge (0 to 1) as a stimulus, whatever the input type (GPI, UCP button)

- **LAUNCH FILE:** allows you to call any Windows application installed on the computer EclerNet Manager is running on:

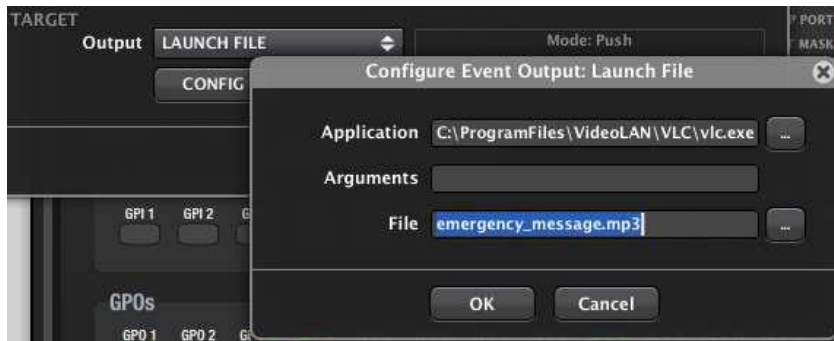

In the above example the output of the event is the playback of the audio file named emergency_message.mp3 by VLC player. Similarly, an event of this type can launch any other application installed on your computer (audio or video playback from a playlist or individual file, Powerpoint presentation, video call software, etc.).

- **SEND E-MAIL:** allows you to send an email to the addresses defined in the Edit→Project Settings menu with the text entered in the Text field:

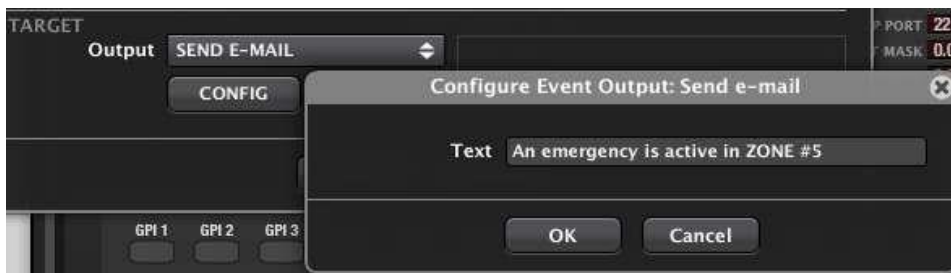

9.1.12.3. Compound digital events

If you select the DIGITAL (COMPOUND) type, the configuration window looks like this:

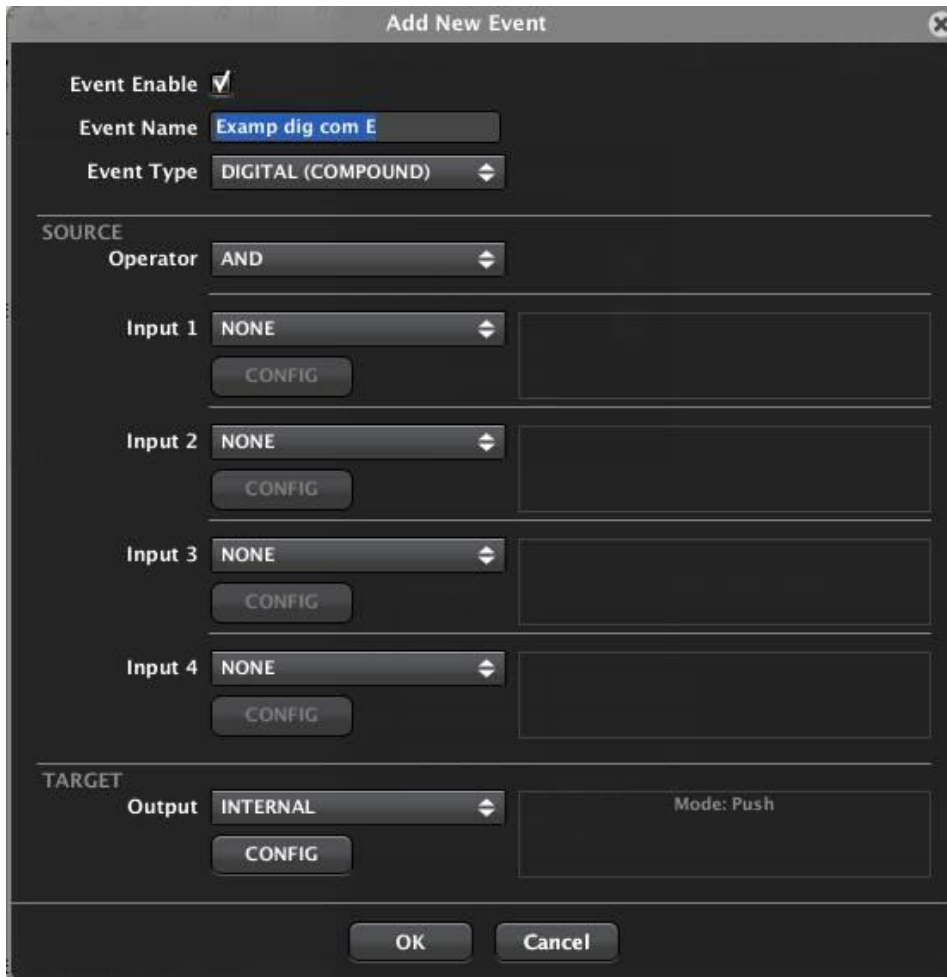

Add New Event

Event Enable

Event Name

Event Type

SOURCE

Operator

Input 1

Input 2

Input 3

Input 4

TARGET

Output Mode: Push

Within the configuration of stimuli for the event input, the first option to select is the Boolean operator that will be used to operate on the target output:

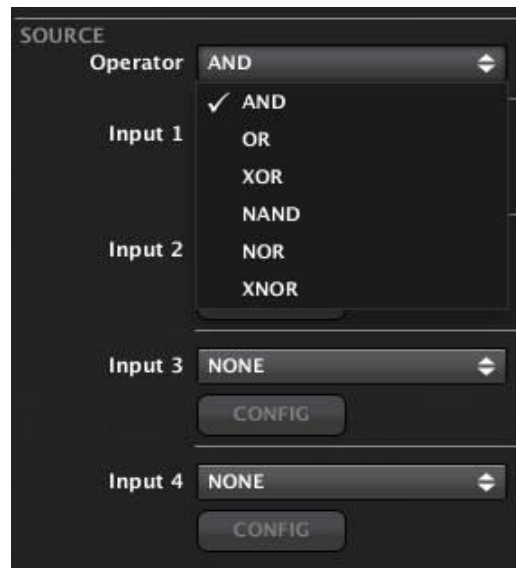

By combining two or more digital input stimuli (values 0 or 1), and depending on the applied logical operator, we obtain the following result:

- **AND:** all stimuli should be = 1 to obtain 1 at the output (event triggering)
- **OR:** one or more of the stimuli must be = 1 to obtain 1 at the output
- **OR (exclusive OR):** only one of the stimuli must be = 1 to obtain 1 at the output
- **NAND: (negative AND):** you get a 1 at the output when at least one of the input stimuli is = 0 (a 0 is obtained when all stimuli are = 1)
- **NOR (negative OR):** inverse of an OR gate. All stimuli should be = 0 to obtain 1 at the output
- **XNOR: (negative exclusive OR):** you get a 1 at the output when all stimuli are = 1 or all are = 0

Then you must define each input stimuli up to a maximum of 4:

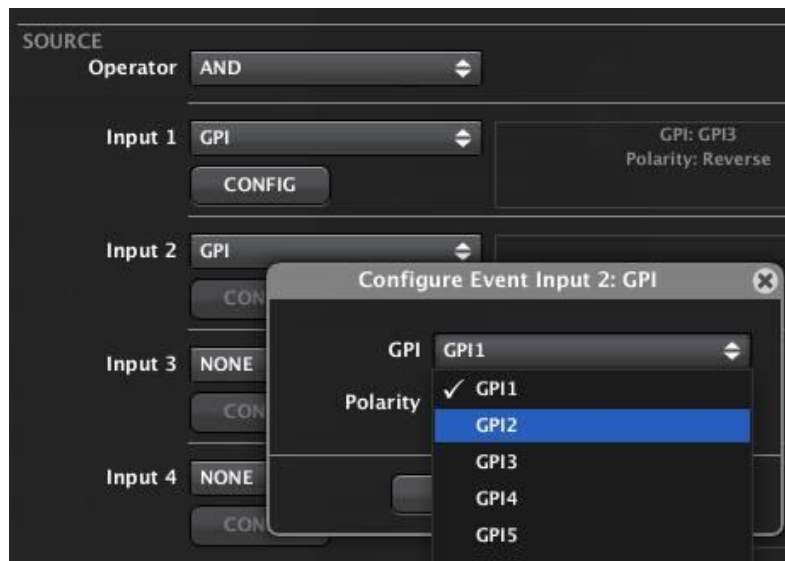

For each of them it's necessary to select the input (GPI, EVENT OUTPUT...) and the DIRECT/REVERSE polarity (0 VDC for 0 and 10 VDC for 1, or vice versa), exactly as for simple digital events. Using EVENT OUTPUT as input for one of the stimuli allows you to concatenate stimuli and thus to exceed the limit of 4 stimuli combined with a logical operator to operate on the same target.

Note: to select the F1 or F2 key of a MPAGE16 / eMPAGE station as input for a digital event, you must first create a simple event with this key as input and link its output to one of the inputs of the compound digital event. This is because F1 and F2 keys can't be assigned to a TOGGLE or PUSH operation until they are processed by a simple digital event.

Finally, you need to define what will be the event output or target and the TOGGLE or PUSH behaviour, also exactly as for a simple digital event:

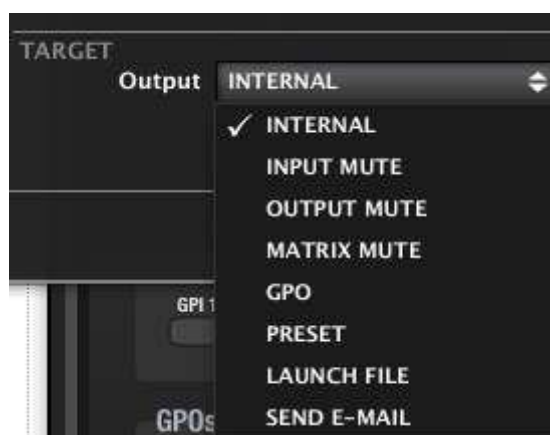

9.1.12.4. Delayed digital events (DIGITAL DELAY)

Such events can set a delay time between the stimulus detection and the destination triggering or event output, as well as a holding time of this activated status for the output (for example: 10 seconds after detecting an external contact closure connected to a GPI, a relay (GPO) status changes for 90 seconds, then returns to its previous state).

From the moment the input stimulus is detected (trigger time), depending on whether the event is set to positive logics (high level or “1” is considered as active level) or negative logics (low level or “0” is considered as active level), the timing of these events is shown in the graph below:

POSITIVE LOGICS

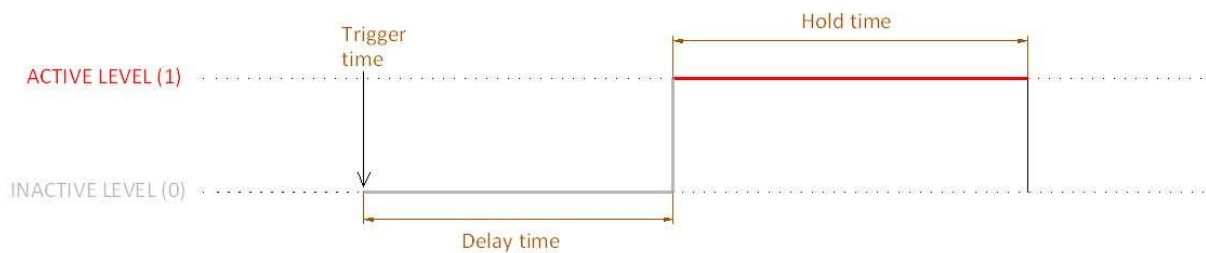

NEGATIVE LOGICS

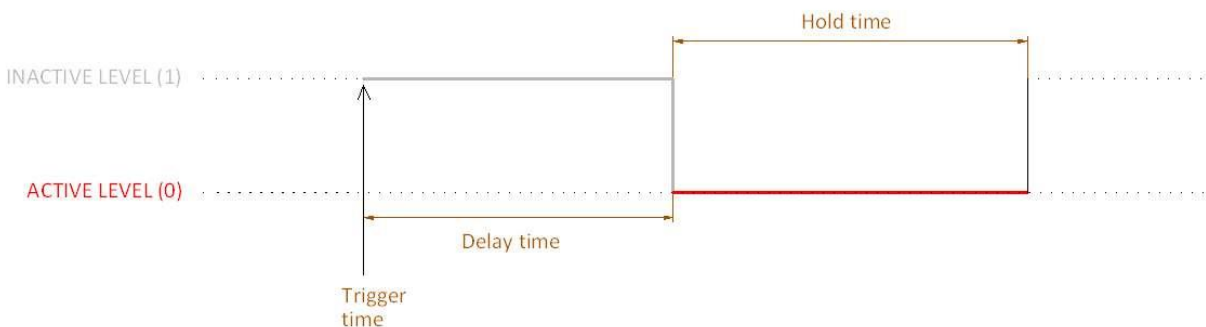

The Delay time is the period from stimulus detection to event triggering during which the inactive state is maintained (0 for positive logics, 1 for negative logics).

Hold time is the period during which the event keeps the active state (1 for positive logics, 0 for negative logics).

After selecting the DIGITAL DELAY type of event, the configuration window looks like this:

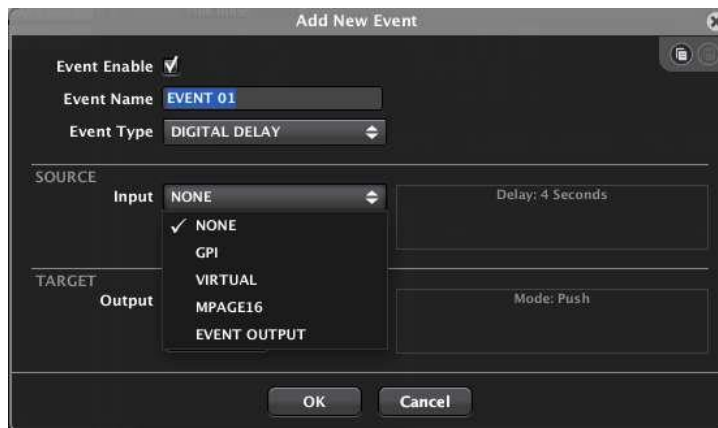

After selecting the input type (options are the same as for a simple digital event), you must configure the way it will behave:

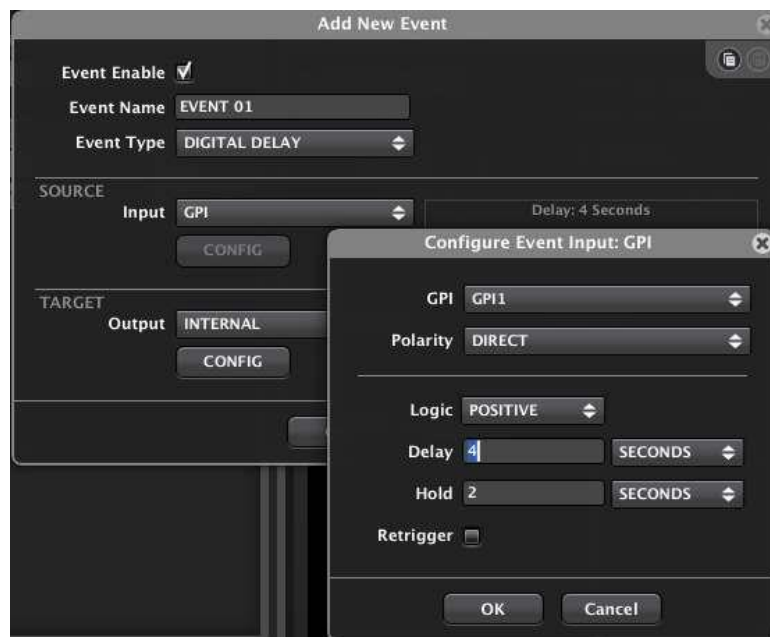

- Select the trigger input (GPI, virtual control, MPAGE16 / eMPAGE station key or event output) you want from the dropdown list.

NOTE: From EclerNet Manager v6 onward, the DUCKER has been introduced as a new input option for digital events in the MIMO4040CDN / MIMO7272DN. In this way it is possible to activate a digital event using audio signal detection: the audio signal that exceeds the threshold level set in a DUCKER module parameters, will activate a digital event. This offers very powerful options of control and automation.

- **POLARITY:** select the detection polarity for trigger or input stimulus, DIRECT/REVERSE:
 - **DIRECT:** for rising edge-triggering: from 0VDC to 10VDC for a GPI, when pressing an UCP key, etc.
 - **REVERSE:** for falling edge-triggering: from 10VDC to 0VDC for a GPI, when releasing an UCP key, etc.

Note: For example, a Preset recall has to be done with a rising edge (0 to 1), so it is recommended to use a positive logic type.

- **LOGIC:**
 - the active state of the event is considered a “1” or high level (positive logic)
 - the active state of the event is considered a “0” or low level (negative logic)
- **DELAY:** period of time between the trigger detection and the switch to the active state of the event
- **HOLD:** time during which the event is held in its active state
- **RETRIGGER:** check box to validate the event re-triggering, which provides the following options:
 - **Checked:** once an event trigger is detected, if a second stimulus of the same trigger is detected before the end of the hold time, process is reset, starting over the time count of delay time + hold time.
 - **Unchecked:** any trigger stimulus received after the first one will be ignored if the hold time period is not elapsed

Finally, we must define what will be the output or destination of the event and its PUSH or TOGGLE behaviour, here again exactly as we proceed in the case of a simple digital event:

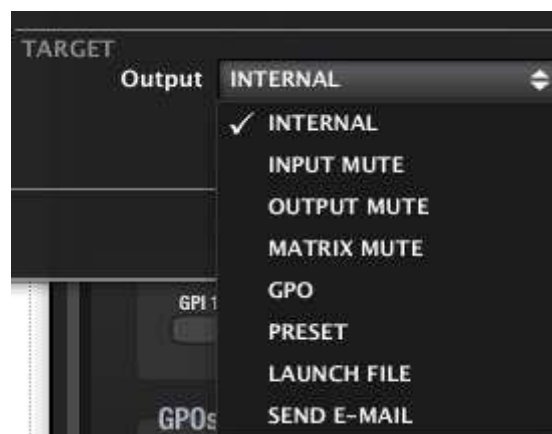

9.1.12.5. Calendar-based events (TIME SCHEDULER)

This type of event receives its input stimulus according to a calendar with date and time of onset, duration, days of the week it must be activated or not, repetition by time interval or number of repetitions and end date. The MIMO88 has an internal clock that allows the management of such events, even if not connected to a computer and synchronized with EclerNet Manager.

When selecting an event of this type to create or edit it, the following configuration window opens:

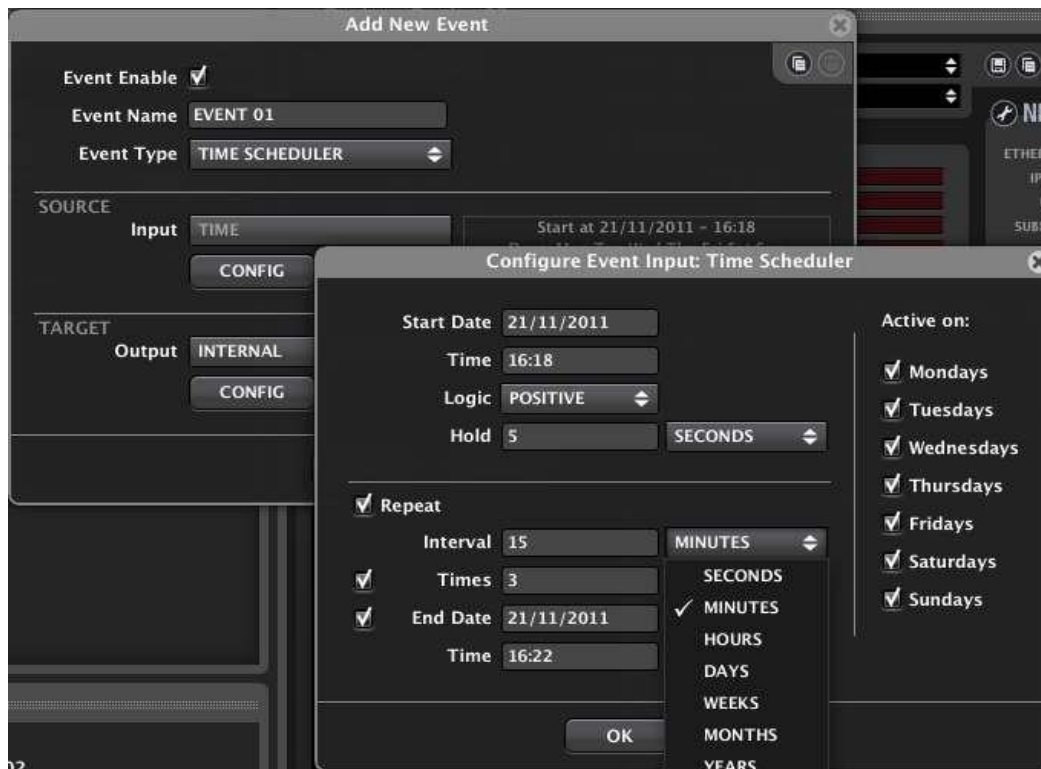

- **START DATE / TIME:** date and time the event activation period starts from
- **ACTIVE ON:** days of the week for which the event triggering is enabled or not
- **LOGIC:**
 - the active state of the event is considered a “1” or high level (positive logic)
 - the active state of the event is considered a “0” or low level (negative logic)
- **HOLD:** time during which the event is held in its active state
- **REPEAT:** if the check box is checked, the event may be triggered several times from the start date and time:
 - **INTERVAL:** time interval between a trigger and the next one
 - **TIMES:** number of repetitions of the trigger
- **END DATE / TIME:** end date of the period enabled for repetitions

Note: If TIMES and END DATE / TIME check boxes are checked, the event triggering will occur the number of times that meets the more restrictive condition of the two options.

Finally, we must define what will be the output or destination of the event and its PUSH or TOGGLE behaviour, here again exactly as we proceed in the case of a simple digital event:



9.2. MIMO88 CONFERENCE digital matrix

9.2.1. MIMO88 CONFERENCE Introduction

The new MIMO88 CONFERENCE has been specially designed for conferencing applications and generally for all applications that require an automatic mixing of microphone signals and / or feedback cancellation (audio feedback or Larsen effect).

The differences between the "CONFERENCE" version (hereinafter MIMO88CONF) and the standard version of the MIMO88 digital matrix are:

- Identical hardware for both versions
- Different firmware between standard version and conference version

Consequently, any MIMO88 hardware can be upgraded with either firmware to convert it as a standard MIMO88 version or a MIMO88CONF. The process is simple and quick, and can be performed as many times as necessary, so that by having MIMO88 hardware units it's possible to provide customers and users any version of MIMO88, depending on the intended application.

MIMO88CONF basically shares many of the standard MIMO88 functions:

- Inputs and outputs processing (levels, EQ, noise gate, etc.), with slight differences from the standard version
- Management of the routing matrix (state and levels of the crossing points), with slight differences from the standard version
- Management of priority signals (evacuation, emergency)
- Management of GPI and GPO control ports
- Management of digital and analogue remote controls (WPTOUCH, etc.)
- Presets management
- Events management
- Individual configurations (8 in, 8 out) or as a MASTER/SLAVE couple (16 in, 16 out)
- Programming and control using EclerNet Manager application software
- Remote control via TP-NET, Ethernet or RS-232 protocol (Third-Party Protocol)
- Remote control via UCP (User Control Panels)

And presents some differences compared to a standard MIMO88:

- **INPUTS Section:**
 - Each input channel includes the Frequency Shifter function, independently enabled (also included in the new versions of the standard MIMO88)
 - Delay is removed from inputs, it is available on outputs only
- **OUTPUTS Section:** EQ including 4 parametric filters, without crossovers
- **MATRIX Section:** 4 outputs with totally independent routing (1 to 4) + 4 outputs (5 to 8) that can receive the processed signal from one of the first 4 outputs, while independently maintaining volume controls and DELAY
- **DUCKERS Section:** PAGER modules are removed and a DUCKER module is enabled for the management of emergency / evacuation signals
- **AUTOMIXER Section:** new section for the configuration of the automatic mixing
- **FEEDBACK KILLER Section:** new section for the configuration of the 2 available modules dedicated to feedback cancellation, each one of them including 8 notch filters with automatic adjustment
- **REMOTES Section:** MPAGE16 / eMPAGE digital remote-control type is deleted, as PAGER modules are not available in this version



The reason for these differences lies in the need to accommodate the new high-demand features DSP code in the device processors. It was necessary to optimize the resulting code in which certain features of the standard version have been set aside for the benefit of the MIMO88CONF new features.

Both AUTOMIXER and FEEDBACK KILLER settings can be stored and retrieved using presets. In this way, different presets can store different configurations of these two new sections, in order to instantly recall those presets.



9.2.2. MIMO88 CONFERENCE Firmware Update

Starting from a standard MIMO88 hardware unit, the procedure for updating your firmware and convert the unit into a MIMO88CONF is as follows:

1. Connect the MIMO88 unit and the networked computer running EclerNet Manager and modify your network settings to have full connectivity, as detailed in section 7.4 of this manual (*Network Configuration*).
2. Add the MIMO88 device to the current project (drag and drop from the folder "Online and Unused Devices" to the folder "Devices -> All").

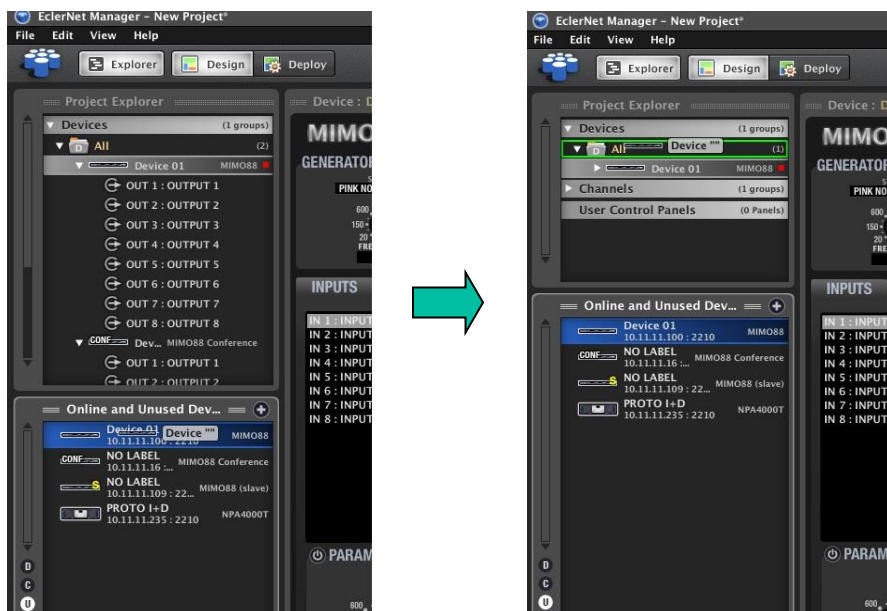

- Once the device is added to the project and "online" or connected (right mouse button -> Connect -> Green fixed icon to its right), access the dialogue box that allows you to load the firmware file from a device (with .bin extension) and transfer it to the device in question.

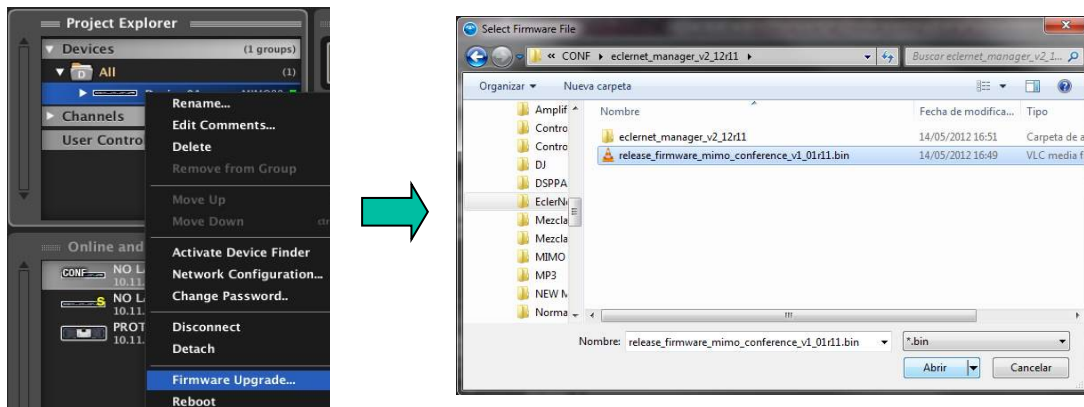

- A progress bar appears on the screen during the device firmware update.



- And then a message of completion of the process.



- After this, the device automatically performs a full boot cycle (a "reset" or restart), appearing in the EclerNet Manager application under its new identity, MIMO88CONF.



From this time the new MIMO88CONF is ready to be used as the other EclerNet Manager compatible devices: insertion in a project, modification of its detailed configuration, remote management from UCP panels and via TP-NET protocol, etc.

The following paragraphs describe the general operation of the MIMO88CONF. Given that many of the features available in the MIMO88CONF are common to the ones in the standard MIMO88, the next sections will especially detail the differences with the standard version, as well as how to operate the new features included in the MIMO88CONF version: FREQUENCY SHIFTER, AUTOMIXER and FEEDBACK KILLER. It is highly recommended to also refer to chapter [EclerNet COMPATIBLE DEVICES: MIMO88 digital matrix](#) for in-depth understanding of processing and control features and capabilities that are common to MIMO88 and MIMO88CONF.

9.2.3. INPUTS Section and FREQUENCY SHIFTER function

The aspect of the INPUTS section of the MIMO88CONF is as follows:



Comparing it with the same section of the MIMO88 standard version, there is no DELAY adjustment for each input, although delay settings are maintained for each output of the unit.

Each input has a new function named FREQUENCY SHIFTER (bottom right corner), an efficient system to reduce the risk of feedback loops (audio feedback or Larsen effect) when a microphone source is near the speaker(s) producing its signal, once amplified. When activated, this function slightly shifts the incoming signal frequency on the affected channel before sending it to the matrix mixer and then to the selected output. The shift is so slight that it is barely noticeable to the listener, especially when it occurs in the frequency range of the human voice. A few cycles (Hz) displacement is enough to greatly increase the system protection against possible feedbacks.

9.2.4. MATRIX Section

The aspect of the MATRIX section of the MIMO88CONF is as follows:

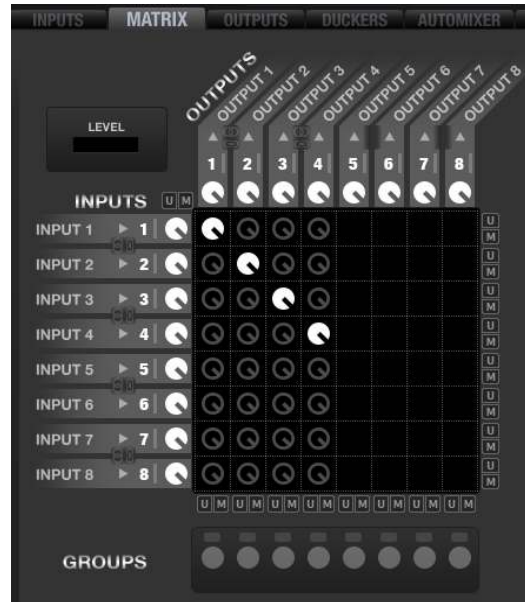

The image shows that the MIMO88CONF has the ability to process any mix of inputs you may have sent to one of the first 4 outputs on the unit. In other words, it is possible to generate up to 4 independent mixes, using any combination of the 8 available inputs as sound sources.

If you use a MASTER/SLAVE couple of MIMO88CONF, the appearance of the matrix would be the following:

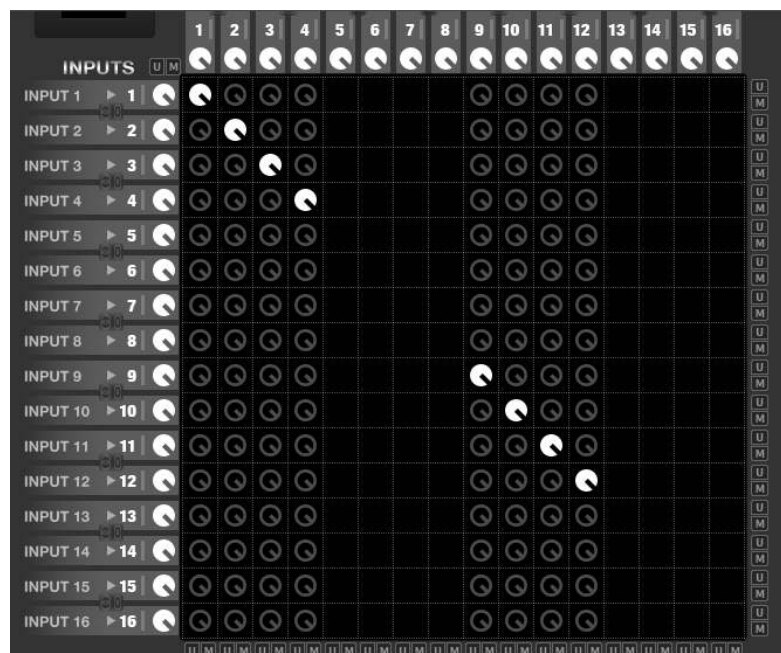

In this case it is possible to process up to 8 independent mixes (outputs 1 to 4 and 9 to 12) using any combination of the 16 available inputs as sound sources.

Of course, the linking groups, the matrix management using presets, etc. that are available in the standard version are still available in the CONF version (see **MIMO88** for more information about these functions).

Outputs 5 to 8 and 13 to 16 (in the case of a master/slave configuration) can be fed with the signal of one of the available mixes (outputs 1 to 4 and 9 to 12), but with independent level control and DELAY:

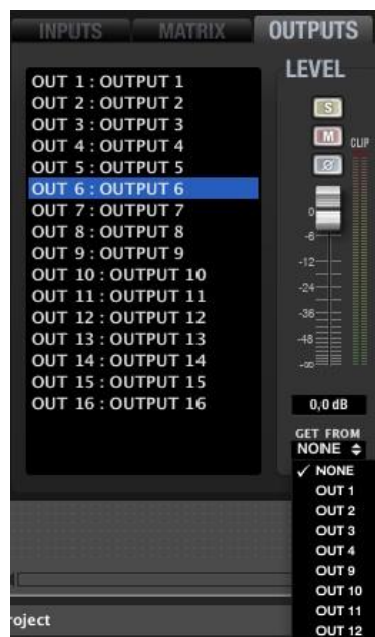

9.2.5. OUTPUTS Section

The aspect of the OUTPUTS section of the MIMO88CONF for outputs 1 to 4 and 9 to 12 is as follows:



The image shows that the MIMO88CONF outputs only have two differences compared to the standard version (see **MIMO88** for more information about these features):

- No crossover filters
- 4-Band parametric EQ (8 in the standard version)

The aspect of the OUTPUTS section of the MIMO88CONF for outputs 5 to 8 and 9 to 16 is as follows:

INPUTS MATRIX **OUTPUTS** DUCKERS AUTOMIXER F.B.KILLER GPIs/GPOs REMOTES

OUT 1 : OUTPUT 1
OUT 2 : OUTPUT 2
OUT 3 : OUTPUT 3
OUT 4 : OUTPUT 4
OUT 5 : OUTPUT 5
OUT 6 : OUTPUT 6
OUT 7 : OUTPUT 7
OUT 8 : OUTPUT 8
OUT 9 : OUTPUT 9
OUT 10 : OUTPUT 10
OUT 11 : OUTPUT 11
OUT 12 : OUTPUT 12
OUT 13 : OUTPUT 13
OUT 14 : OUTPUT 14
OUT 15 : OUTPUT 15
OUT 16 : OUTPUT 16

LEVEL

S
M
CLIP

0
-6
-12
-24
-36
-48
-∞

0,0 dB

GET FROM
OUT 3

DELAY

MIN MAX
50,7 ms

Channel "OUTPUT 5"



The previous image shows the following differences compared to the output groups 1 to 4 and 9 to 12:

- An output signal should be selected in the list (OUT1 to OUT4 and OUT9 to OUT12)
- No processing except the DELAY setting, especially useful when using these outputs to deliver a signal to a sound reinforcement system located at some distance from the main speakers, and to time-align the main speakers and the reinforcement speakers

9.2.6. DUCKERS Section

The aspect of the DUCKERS section of the MIMO88CONF is as follows:



The differences compared to the standard version are:

- No PAGER modules (so this version is not compatible with the MPAGE16 / eMPAGE paging station)
- One single DUCKER module for handling signals with highest priority (emergency or evacuation messages, etc.). The module can act directly on the 4 or 8 outputs with full mixing functionality (1 to 4 / 9 to 12). If one of them is selected as sound source for any of the outputs 5 to 8 or 13 to 16, the DUCKER will also act on the destination output(s).

9.2.7. AUTOMIXER Section

AUTOMIXER is a function available only in MIMO88, MIMO88SG and MIMO12SG CONFERENCE versions, that allows to perform automatic mixing of incoming audio signals, while maintaining a control (also automatic) on the total gain of the mix and managing some parameters and priorities between these signals.



The AUTOMIXER processing module uses a very sophisticated algorithm to manage what input signals must be part of the automatic mix and under what conditions, and what signals must remain apart. The AUTOMIXER analyses the audio content on all inputs to identify what should be considered as background noise and what should be considered as a valid signal to trigger the input channel in the auto mix.

A clear and frequent example would be a conference application in a room with multiple microphones assigned to the automatic mixing process as sound sources. The signals simultaneously captured by all the microphones with a less high intensity could be considered as indirect, i.e. coming from a lecturer with the intention to be picked up by his own microphone, but inevitably also captured by the rest of the microphones in the room. In contrast, the signal picked up by the microphone of the speaker itself should logically be of much greater intensity.

The algorithm considers a large set of parameters related to the indirect signals to calculate in real time the background noise level of the mix and, from there, allows the signals exceeding some magnitude (set with the THRESHOLD setting) to enter and be part of the automatic mix. Inputs that do not meet the requirements to be considered as part of the automatic mix are attenuated by a number of decibels set with the DEPTH parameter (in certain applications it is preferable not to completely mute signals excluded from the automatic mix, but to attenuate them to a certain extent).

To the left of the screen you will find a list of all unit inputs, where you can select inputs you want to be a part of the automatic mix (left button in green for the selected inputs). The multicolour indicator to the right of each input shows its status at a given time:

- **Red:** the input level is below the threshold of the noise gate that allows the input of the signals in the automix (noise gate closed). Inputs 4 and 5 in this example.
- **Yellow:** the input level has exceeded the noise gate threshold (opened gate), but the input is not currently included in the automatic mix, according to criteria established for the automatic mixing algorithm. Input 3 in this example.
- **Green:** the input level has exceeded the noise gate threshold (opened gate) and the input is currently included in the automatic mix. Inputs 1 and 6 in this example.

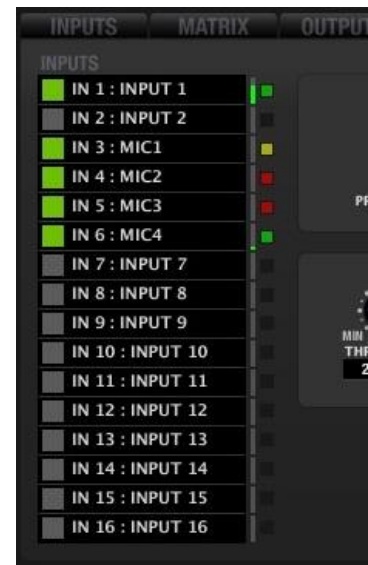

The small green level meters located to the right of the list indicate the activity of the signal present on each input.

To the right of the screen you will find another list, including all the device outputs, where you can select the outputs the automatic mix will be affected to. In this example, the automatic mix done in the AUTOMIXER module is routed to outputs 3, 4 and 10.

The small green level meters located to the left of the list indicate the activity of the signal present on each output.

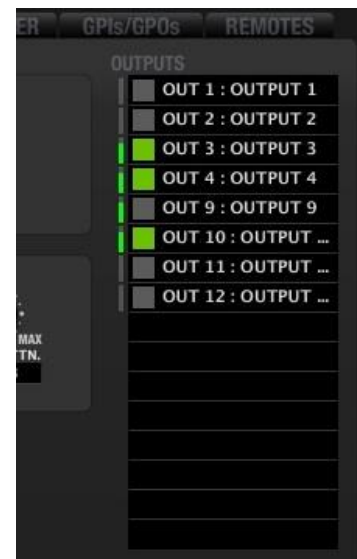

The inputs assigned to automatic mixing in the AUTOMIXER module must first be properly assigned in the MATRIX section, by adjusting the MUTE and level controls of its crossing points to correctly route them toward the desired outputs.

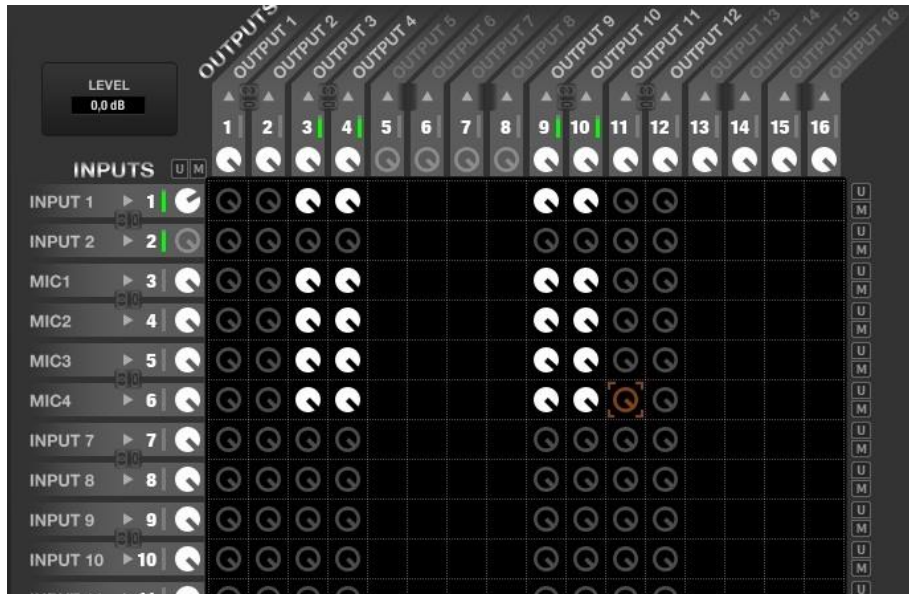

The picture above shows how inputs 1, 3, 4, 5 and 6 are routed toward outputs 3, 4, 9 and 10. Thus it would be possible that any selection of these inputs and outputs in the AUTOMIXER module could result in an automatic mixture according to the settings made in this module.

9.2.7.1. AUTOMIXER. NOMA or EXCLUSIVE automix modes

The AUTOMIXER has two operating modes:

- **NOMA:** “Number of Open Microphones Attenuated”. In this mode, the automatic mixing algorithm allows a fixed number of input signals (usually picked up by microphones) to be simultaneously part of the mix, reducing or increasing their total gain when the number of microphones included in the mix increases or decreases (more active signals in the mixture, less total gain).
- **EXCLUSIVE:** in this mode only, a single microphone is part of the mixer channel at a given moment, once the algorithm considers that it complies with its requirements. Another microphone can be used when the first one has released the channel.

The user controls of the AUTOMIXER section are the following:



- **MODE:** NOMA or EXCLUSIVE mode selection
- **MAX. NOM (NOMA mode only):** maximum number of signals that may simultaneously be part of the automatic mixing. Regardless of the number of inputs that have been selected in the INPUTS list (to the left of the AUTOMIXER window) as candidates to be automatically mixed, the MAX. NOM parameter sets how many of them can be mixed at a given moment with the automix algorithm. For example, if the application consists of 8 lecturer microphones, but MAX. NOM is set to a value of 4, only a maximum of 4 of these 8 microphones (from 0 to 4, in fact) are actually mixed automatically, although the 8 microphones capture signals above a certain intensity, the algorithm deciding at all times which of the 8 eligible inputs will join the mixing bus.
- **LAST ON:** when this option is enabled, at least the last signal to join the mixing bus will permanently remain in it, even when it no longer meets the input criteria, being composed only by weak signals or background noise. In this mode, the mixing bus will never remain fully silenced, thus avoiding the uncomfortable effect of audio "disconnection" of the system during the intervals in which there are no valid signals for the automatic mixing process.
- **PRIORITY INPUT:** if desired, define a device input that will have the highest "chairman" priority. When this input exceeds the noise gate threshold, it will become part of the mixing bus, inhibiting the other signals. The priority signal is the one that usually comes from the microphone of a moderator or chairman during conferences, debates, etc.
- **THRESHOLD:** input level of the signals in the automix bus, based on the internal threshold that the internal mixing algorithm automatically and dynamically calculates. The higher the setting, the greater the difficulty for the input signals to be incorporated into the mixing bus (a higher level will be required).

- **DEPTH:** attenuation level applied to the signals that are outside of the bus at a given moment.
- **HOLD:** holding time of the signals within the mix bus, once they have entered into it, and after leaving to meet again with the criteria of admission
- **NOM ATTN.:** attenuation applied to the total gain of the automatic mix bus whenever the number of signals contained therein is doubled

9.2.8. FEEDBACK KILLER Section

FEEDBACK KILLER is a new section, available only in MIMO88CONF. The new section includes "notch" type filters with automatic adjustment, whose mission is to reduce the risk of audio feedbacks (or Larsen effect).

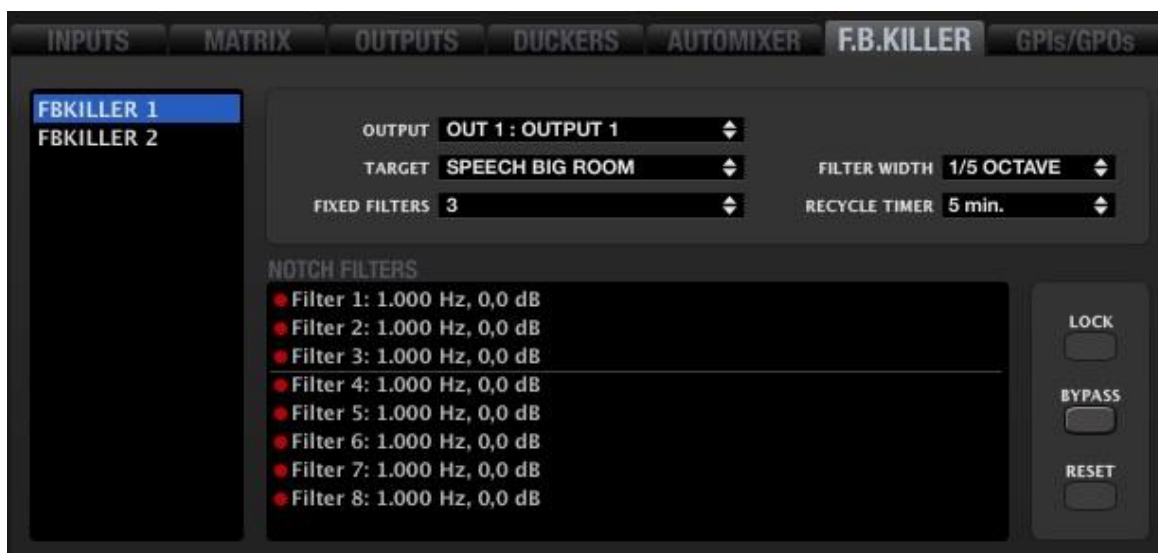

The FEEDBACK KILLER section consists of 2 banks, with 8 automatic filters in each one of them. The 2 banks are independent in terms of settings, operating mode and assigned output.

According to the settings, the FEEDBACK KILLER algorithm continuously analyses the input-output loop assigned to each bank, detecting in real-time frequencies prone to feedback then automatically assigning notch filters to these frequencies. Each notch filter is set (centre frequency and attenuation) to reduce the level of a band of frequencies in order to avoid a feedback effect.

The image shows the bank 1 with 6 of its 8 filters assigned to frequencies that the algorithm has detected as prone to feedback:

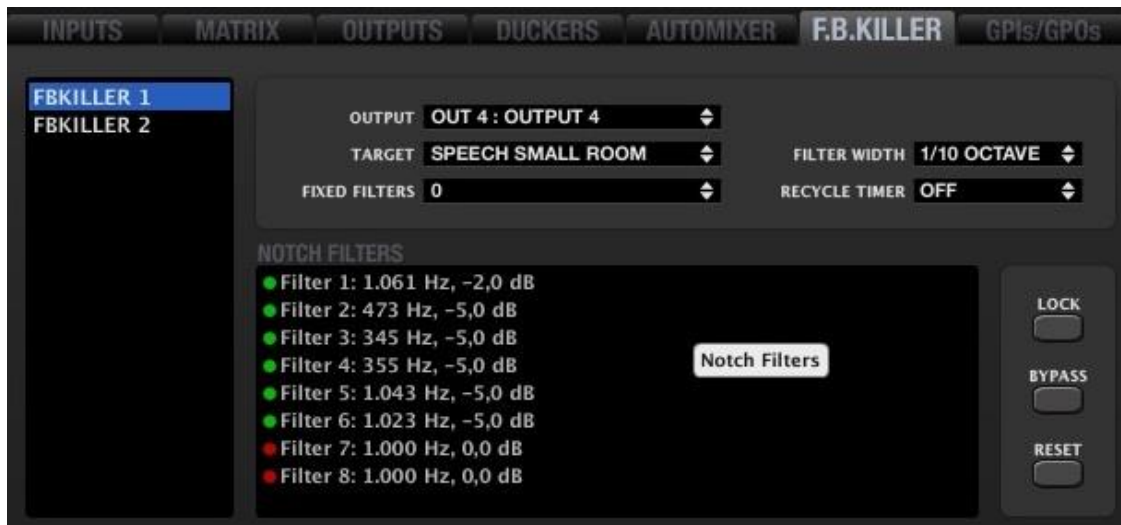

To the left of the window is the selection list for one of the two banks (FBKILLER 1 and FBKILLER 2). Clicking on one of them allows you to adjust their settings:

- **OUTPUT:** the system output the filter bank is applied to in order to cancel or minimize its potential feedbacks (outputs 1 to 4 and also 9 to 12 in the case of a MASTER-SLAVE MIMO88CONF)
- **TARGET:** allows you to select among 4 preset application profiles, each one of them with the algorithm optimized for the application. Each of these profiles adjusts algorithm internal parameters such as the feedback detection sensitivity and the maximum attenuation applied by the filters. It is important to correctly set this parameter considering the application characteristics (music or speech) and the room type where to work (large or small), given that its own reflections and modes differently affect the risk of feedback in all the cases considered as profiles for the TARGET parameter. A conference application using a MUSIC profile will surely give worst results than if you employ a SPEECH profile, and vice versa.

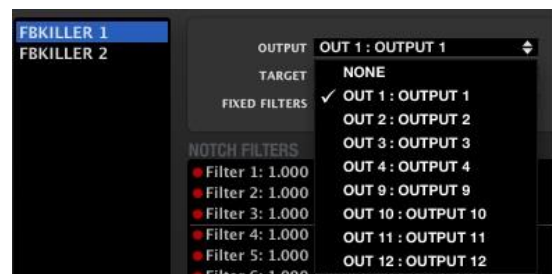

- **FIXED FILTERS (from 0 to 8, per bank):** determines the number of filters that, once set, remain fixed over time (static) until you change the MIMO88CONF setting that affects them (recalling a preset with other settings, loading a new project, rebooting the computer, etc.). A



horizontal line visually separates fixed filters (the first three in this picture) from dynamic filters (the following five in this picture). Dynamic filters can be reset over time if the algorithm detects that it is necessary (microphones moved in the room, changes in the acoustic conditions, etc.).

- **FILTER WIDTH (1/5 or 1/10 Octave):** determines the bandwidth of each one of the notch filters of the bank, or the frequency range that will be affected (attenuated) by each filter, using its centre frequency, automatically detected, as the centre of this range

- **RECYCLE TIMER:** determines the minimum necessary time between the setting of each dynamic filter and its releasing for a new setting on another frequency of potential feedback, when the algorithm detected this need

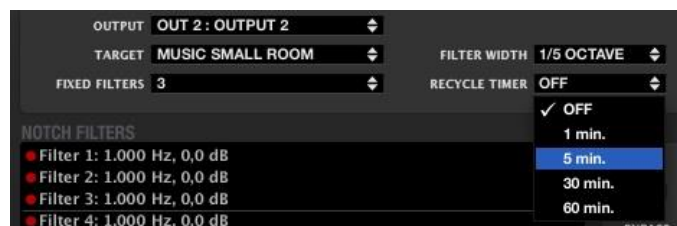

- **LOCK:** locks the status of already set filters, not allowing more static filters setting (if any) nor dynamic filters setting or resetting
- **BYPASS:** when activated, temporarily disables the FEEDBACK KILLER function, while keeping the adjustments and filters set in memory. When deactivated, re-enables the function, recovering the previous settings
- **RESET:** totally resets the 2 banks of filters, now available again for setting

9.3. MIMO88SG and MIMO1212SG matrixes

MIMO SINGLE series (MIMO SG) comes as a demand from the market to have a simplified and price competitive version of the MIMO88, still keeping its superb audio quality and most of its smart processing and control features. The MIMO SG series includes 2 models: MIMO88SG and MIMO1212SG.

Which are the differences when comparing the MIMO88SG / MIMO1212SG to the MIMO88?:

- 8x8 (MIMO88SG) or 12x12 (MIMO1212SG) digital matrix, **not expandable**: the MIMO88 can be expanded to a 16x16 matrix size by linking 2 units
- Digital control bus to connect up to 16 WPTOUCH units (digital touch-sensitive wall panel) and **3 MPAGE16 / eMPAGE units** (digital paging stations): **the MIMO88** admits up to 16 WPTOUCH units and **4 MPAGE16 / eMPAGE units**
- FREQUENCY SHIFTER function to avoid feedback loops, **available in 4 inputs**: in the MIMO88 it is available **in all the inputs (8)**
- **6 parametric EQ filters** per output: **8 filters per output in the MIMO88**
- No GPO relays: **8 GPOs in the MIMO88**
- No headphones / monitor output

Which are the common features when comparing the MIMO88SG / MIMO1212SG to the MIMO88?

- 8 or 12 MIC/LINE balanced inputs and 8 or 12 balanced outputs, with mono or stereo management
- Ethernet and RS-232 communication interfaces
- 8 or 12 GPI ports (General Purpose Inputs): 0-10 VDC control inputs assignable to MIMO functions, like volume control, MUTE function, preset recall, etc
- Fully programmable and controllable via EclerNet software (directly wired to a PC or by means of an Ethernet network)
- UCP (User Control Panels) remote control system, compatible with WPmSCREEN / WPNETTOUCH and third-party devices, such as computers, tablets, smartphones, etc.
- TP-NET protocol compatible, for third-party control systems integration
- A few processing bits: signal generator, delays, full parametric EQ filters at inputs and outputs, inputs noise gate, level, mute, phase, vu-meters, outputs compressor / limiter, paging and ducking (priority & overriding), virtual and physical paging stations management, presets save & recovery, scheduled events triggering, etc.
- STANDARD and CONFERENCE firmware versions available

MIMO88SG and MIMO1212SG do not replace MIMO88, but come as new products in Ecler's catalogue.

As for how to program and control the MIMO88SG / MIMO1212SG, please refer to this manual's chapters related to MIMO88, MIMO88 CONFERENCE, UCP panels, WPmSCREEN / WPNETTOUCH, etc., and just consider the different and common features explained above.

9.4. MIMO4040CDN / MIMO7272DN Dante™ matrixes

Notes:

MIMO7272DN, MIMO4040CDN and MIMO4040DN are 3 EclerNet matrix models with integrated Dante™ digital audio transmission.

From v6.01r3 (March 2021), the range of EclerNet matrixes with integrated Dante™ will be configured as follows:

- MIMO4040DN is no longer in production → consult previous ENM manual versions to support this product
- A new reference appears: MIMO4040CDN, only available with CONFERENCE firmware version
- A new reference appears: MIMO7272DN, only available with STANDARD firmware version (not CONFERENCE)

In this ENM manual edition, MIMO4040CDN and MIMO7272DN references are supported. For support on the MIMO4040DN reference, see previous versions of the ENM manual.

MIMO7272DN is an installation 72x72 digital audio matrix (72 inputs and 72 outputs), fully programmable through the EclerNet Manager application

It has 8 analog audio inputs and 8 analog audio outputs, 64 Dante™ digital audio inputs and 64 Dante™ digital audio outputs, with an internal native matrix dimension of 64x64 simultaneous input / output channels.

MIMO7272DN is only available with standard firmware, and not with CONFERENCE firmware, intended for conferencing applications. For these applications, see the capabilities of the MIMO4040CDN model.

MIMO7272DN has many of its main features and programming procedures pretty much in common with MIMO88, MIMO88SG and MIMO1212SG, like:

- Inputs DSP processing, each input including mono / ST management, time delay, parametric EQ, noise gate, compressor and frequency shifter (feedback prevention system)
- Outputs DSP processing, each output including mono / ST management, time delay, crossover EQ filters, parametric EQ and level limiter
- I/O matrix management, including fully customisable switching and mixing capabilities for each individual audio output and **40 matrix link groups (Matrix Link Groups)**
- Presets management, being able to save partial configurations in each preset (Inputs setup, Outputs setup, matrix setup, etc.), thus performing partial overwrite actions of a given device status when a preset is recalled
- Pagers / Duckers section: **in this model including 25 Ducker / Pager priority modules**
- Events, triggered by external stimulus (GPIs, UCP controls), calendars or internal scheduling, along with Boolean logic processing
- GPI / GPO section (8 and 8), GPIs ready to behave as events triggers and admitting analogue wall panel controls (source / preset selectors and volume controls)
- UCP (User Control Panels) remote control compatible
- TP-NET (third-party) remote control and integration protocol compatible

Which are the main differences when comparing the MIMO88, MIMO88SG and MIMO1212SG to the MIMO7272DN?

- It has a total of 72 input audio ports and 72 output audio ports. The selection of these ports allows working with the internal matrix of the unit, with a maximum dimension of 64 input channels and 64 simultaneous output channels
- The audio input and output ports are:
 - 8 MIC / LINE analog audio input ports
 - 8 LINE analog audio output ports
 - 64 Dante™ / AES67 digital audio input ports
 - 64 Dante™ / AES67 digital audio output ports
- **Flexible routing** of INPUT and OUTPUT PORTS to the MATRIX module's audio channels, from the internal matrix (from ENM v6 onwards)
- **NTP** clock synchronisation feature (automatic Winter / Summer clock adjustment to enable scheduled events being correctly triggered)
- **UCP webserver included**: the MIMO7272DN can store an EclerNet project and run it, including the UCP panels webserver service, for the whole EclerNet installation and all the UCP potential clients
- Digital remote controls (wall panels): the **WPNET series remote controls (WPNET4KV, 8K and EX)**, compatible with MIMO7272DN, are all of them equipped with **Ethernet interface, and PoE** ready (Power over Ethernet) -> on the contrary, MIMO88, MIMO88SG and MIMO1212SG use a digital CAN bus for the local connection of the WPTOUCH digital wall panels, in daisy chain topology
- Digital paging stations: the new **PAGNETDN paging station, compatible with MIMO7272DN, and with the rest of MIMO matrixes** (MIMO88, 88SG and 1212SG), is as well an **Ethernet and PoE device**. It includes a 10" capacitive touch-screen, ready to handle UCP paging panels and any other kind of UCP general control panels included in the EclerNet project. The **audio output** of this paging station is available **both in Dante™ format (ideal to use it together with MIMO7272DN) and in analogue format**, this last one making it compatible with the other MIMO series matrixes -> on the contrary, MIMO88, MIMO88SG and MIMO1212SG use a digital CAN bus for the connection of the eMPAGE / MPAGE16 digital paging stations, in daisy chain topology

Taking into consideration the above similarities and differences between MIMO7272DN model and the rest of MIMO matrixes (MIMO88, MIMO88SG and MIMO1212SG), the following sections will focus on how to deal with the different and unique MIMO7272DN features.

9.4.1. MIMO7272DN Dante digital audio features

MIMO7272DN features 64 Dante™ / AES67 digital audio input channels and 64 Dante™ / AES67 digital audio output channels (*).

(*) Dante is a combination of software, hardware, and network protocols that deliver uncompressed, multi-channel, low-latency digital audio over a standard Ethernet network using Layer 3 IP packets. Developed by a Sydney-based company named Audinate, Dante builds and improves on previous audio over Ethernet technologies, such as CobraNet and EtherSound. Visit www.audinate.com for further information about Dante™.

MIMO7272DN allows receiving up to 64 digital audio Dante™ channels from an Ethernet local area network and, simultaneously, to send up to 64 digital audio Dante™ channels to the same network, as long as this network is compatible with digital audio transport over IP using Dante™ protocol.

Dante™ channels routing from emitters to receivers in a network, as well as the configuration of the Dante Ethernet interfaces in each of the hardware devices (IP addresses, masks, etc.) are managed using Audinate's software application **Dante™ Controller**. To know how this app works in detail, visit: www.audinate.com/products/software/dante-controller

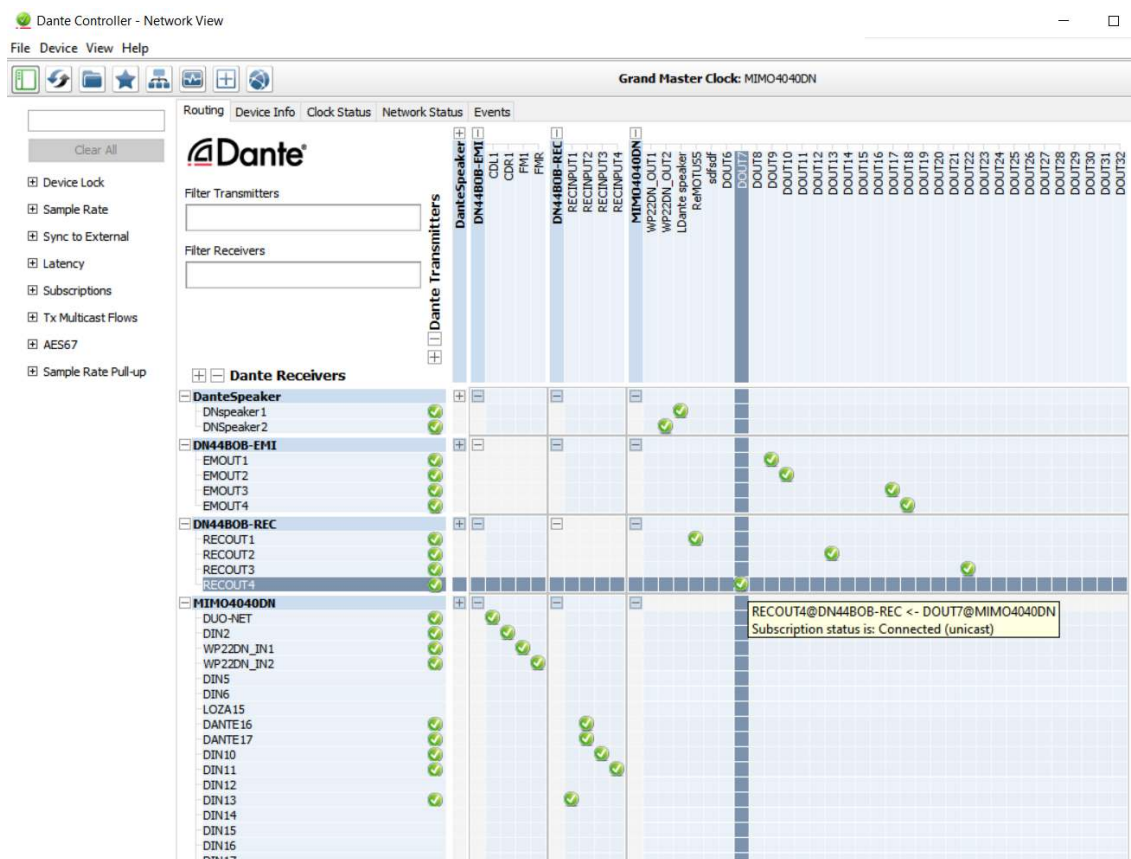

Dante Controller screenshot

MIMO7272DN includes in its back panel two RJ45 Dante™ interfaces, labelled as PRIMARY and SECONDARY. MIMO7272DN can work with these two Dante™ ports in two possible modes:

- Redundant Mode:** two simultaneous network connexions coexist, each one with its own and unique IP address. Dante™ data packets are transmitted through both connections. Each port (Primary and Secondary) must be connected to a different Ethernet network, being it physical or virtual (VLAN), correctly configured and one isolated from the other one. Dante™ digital audio traffic is, therefore, sent and received using two different and totally independent paths, without any communication between the primary and secondary ports. One of these paths is the active one (using the Primary or the Secondary port) and, in case it fails, MIMO7272DN will automatically switch over the other one, recovering the digital audio transmission almost immediately. Obviously, to achieve a system with total Dante™ redundancy, each and every Dante™ device included in it must have both Primary and Secondary ports, respectively connected to the same two independent networks as the Primary and Secondary ports of the MIMO7272DN are connected to.

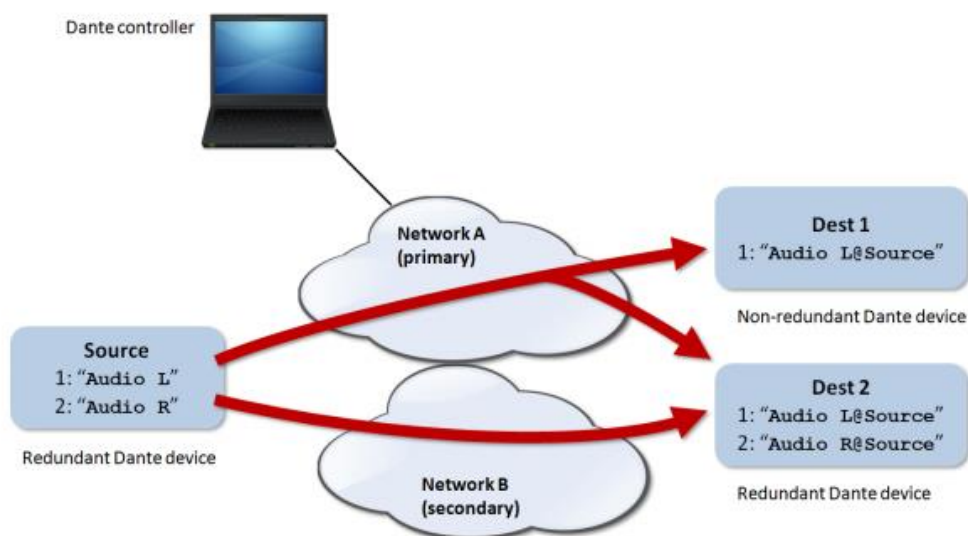

Note: in this mode, if (by mistake) Primary and Secondary ports are connected to the same Ethernet network, Dante Controller application will lose its access to the Dante™ network interfaces and Dante routing of the MIMO7272DN. This access to control is granted again after disconnecting one of these ports from the network the other one is connected to.

Note: Dante™ redundancy requires that Primary and Secondary ports of each and every Dante™ device are connected using the same connection speed to the network. For instance, if the Primary port is connected using a 1 Gbps link, the Secondary port must use a 1 Gbps link as well.

- **Switched mode:** in this mode, there's really just one network connection enabled (and that means just one IP address), and Primary and Secondary ports behave as ports belonging to a network switch embedded inside the MIMO7272DN. It's possible to connect to these ports Dante hardware (directly) or Ethernet switches that allow to connect more Dante hardware devices.

Note: in switched mode, never connect Primary and Secondary ports to the same network switch or to network switches which are interconnected through the network wiring, as this will create a network loop resulting in network conflicts and Dante™ digital audio interruption.

From ENM v6.01r3 onward (Mar 2021), the DEVICE section of MIMO7272DN in EclerNet Manager shows a resuming view similar to this one:

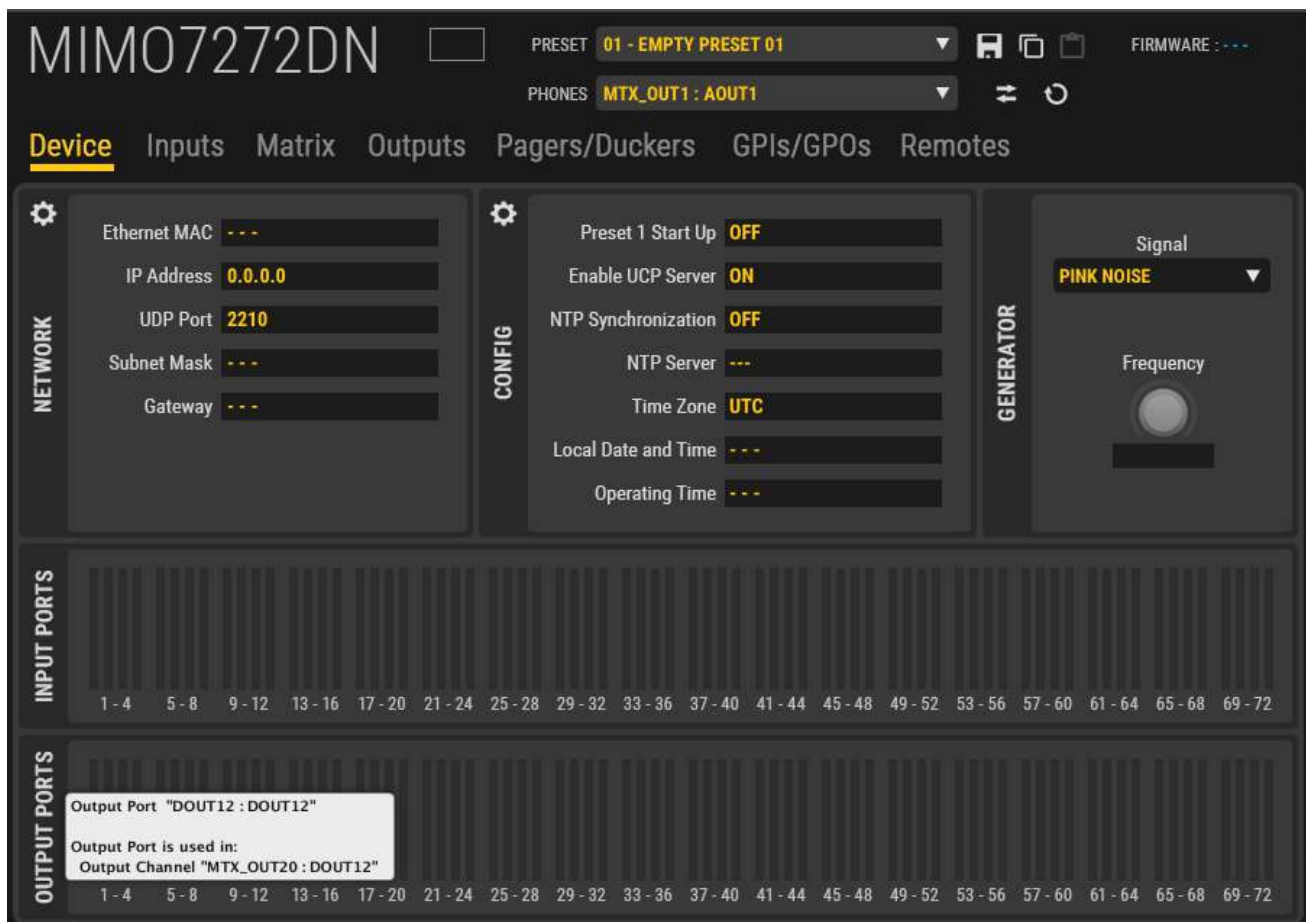

An important improvement from this firmware version is the new visualization of the VU-Meters of INPUT and OUTPUT PORTS in this window.

In this way it is possible to easily check the status of inputs and outputs signals and, **by placing the mouse pointer over the VU-Meter, it is possible to know the details about the signal routing.** This new feature easily provides a panoramic view of the project without moving through INPUT, OUTPUT and MATRIX section pages.

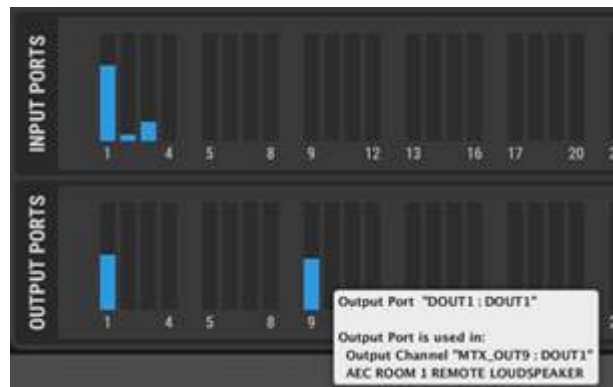

The INPUTS section of the MIMO7272DN in EclerNet Manager shows a view similar to this one:



In comparison with MIMO88, MIMO88SG and MIMO1212SG, an important improvement has been introduced regarding the signal routing flexibility:

Until now (before ENM V6), MIMO4040DN ((predecessor of MIMO7272DN, and like the rest of MIMO models)) had a fixed routing management to the physical inputs:

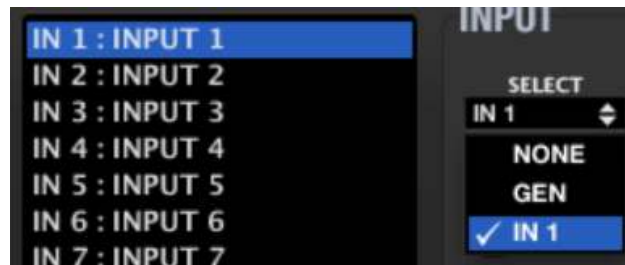

That means: INPUT 1 in the matrix processing can just take its signal from the internal generator or the audio source physically connected to IN1 back panel terminals. The same happens with INPUT 2 -> IN2, INPUT 3 -> IN3, INPUT 9 -> DIN1, INPUT 10 -> DIN2, etc. (Digital inputs can be Dante or AES67)

And the same happened with the matrix outputs, as well with a fixed routing to physical OUTs 1 to 8 (analogue) and, from OUT 9 onwards, to Digital output channels 1 onwards (Dante / AES67):



From ENM v6, this is changing to a much more flexible routing structure:

- The Matrix Input Channels are identified as **MTX_INn : Custom Label**, where **n** is the Matrix channel (1 to 64 for the MIMO7272DN model) and **Custom Label** is, by default, AIN1 to 8 / DIN 1 to 56:

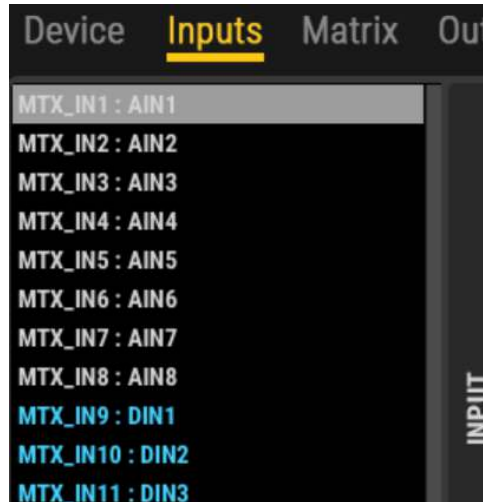

Custom labels can be renamed (right mouse click or F2):



...and then these labels are showed up in the Matrix view as well:



- Any of the 64 Matrix Input Channels can get its audio signal from any of the 72 audio sources (we call them **Input Ports**) that a MIMO7272DN can admit: 8 analogue inputs and 64 Digital (Dante / AES67) input channels. The selection is done by clicking on the Input Port selector:

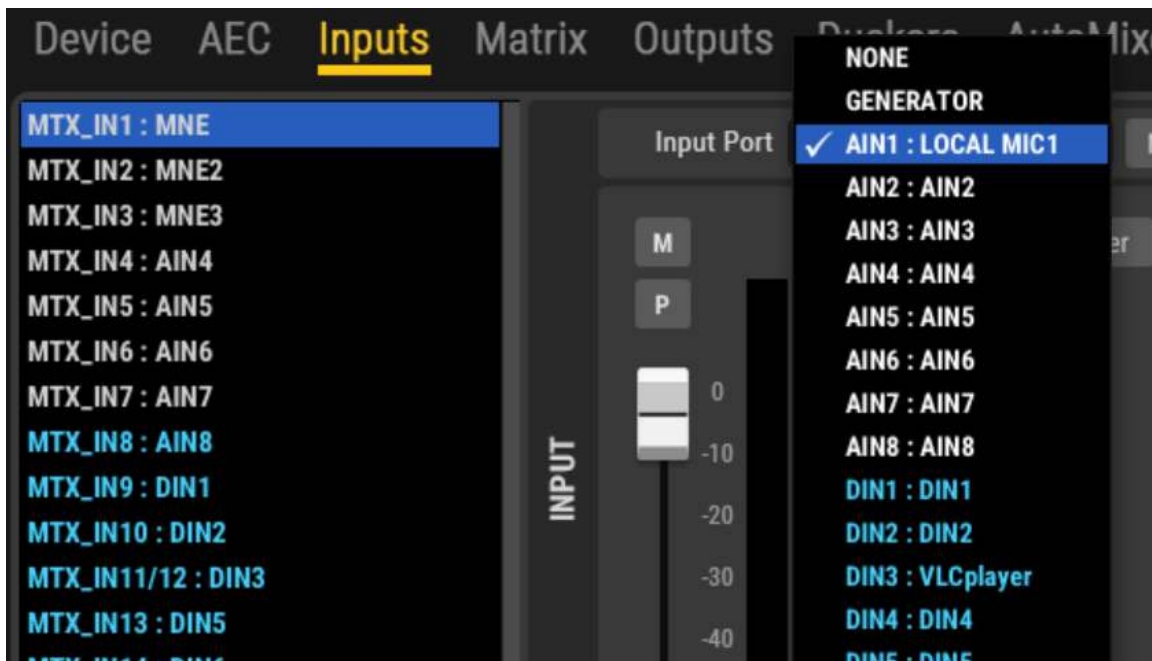
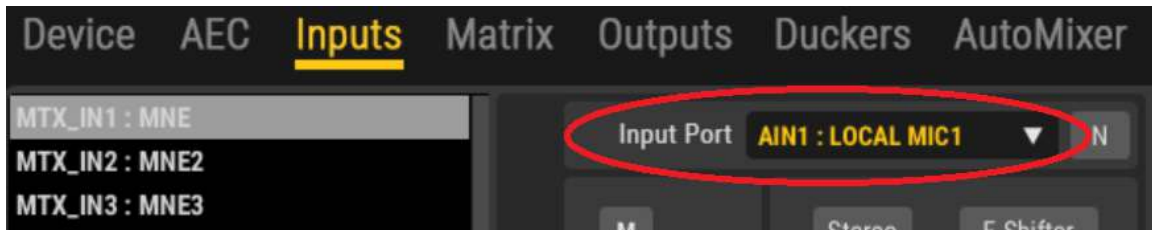

Input Ports have this name structure: **InputPort_n : Custom Label**, where:

- InputPort_n:**
 - AINn, where n= 1 to 8, for the analogue audio inputs of the MIMO7272DN unit
 - DINn, where n = 1 to 64, for Dante / AES67 channels received by the MIMO7272DN unit
- Custom Label (by default):**
 - AINn, where n= 1 a 8, for the analogue audio inputs of the MIMO7272DN unit
 - DINn, where n = 1 a 64, for Dante / AES67 channels received by the MIMO7272DN unit (or the Dante label they may have)

Input Ports custom labels can be as well renamed to get a much friendlier identification in a project:

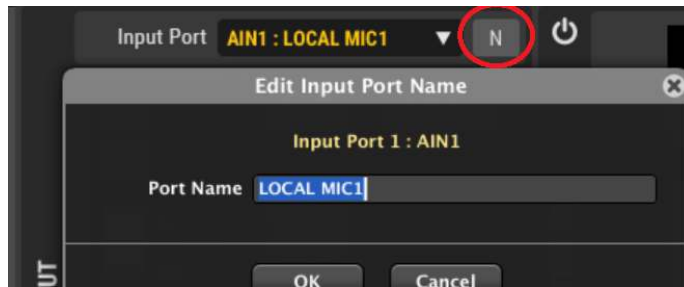

In this way, any analogue or digital source received by a MIMO7272DN can be routed to one or more Matrix Input Channels, with total freedom. That delivers more power and flexibility to configure and manage the audio projects in a MIMO7272DN.

In case a MTX_IN Channel that gets audio from an Analogue Input Port is switched to a Digital Input Port, its colour in the list will change in blue, and vice versa.

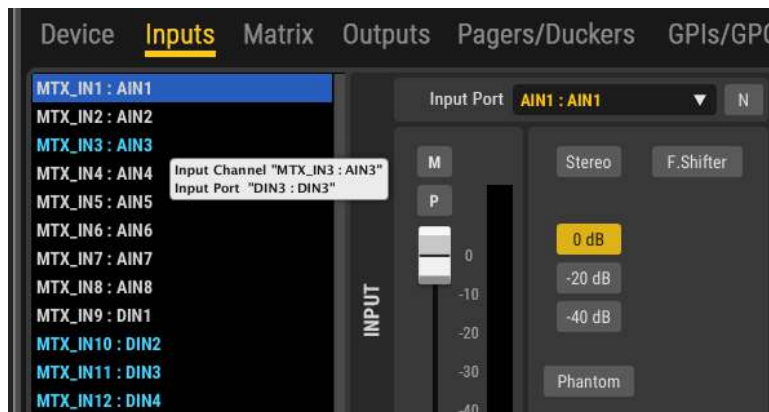

The same routing flexibility degree is available for the Matrix Output Channels and the 72 available Output Ports:

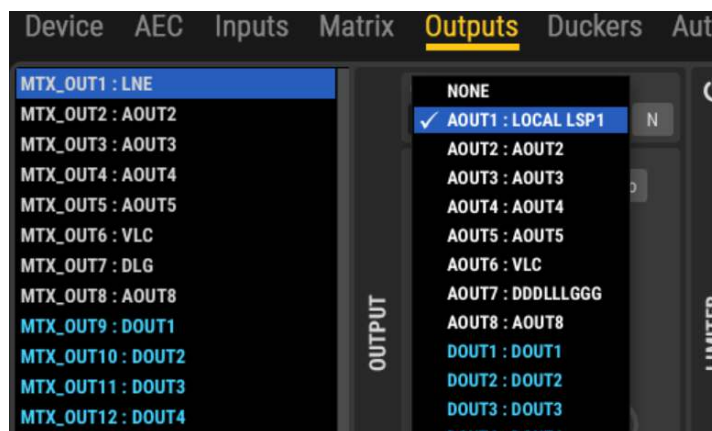

Note: whenever two or more Matrix Output Channels are routed to the same Output Port, this Output Port will get a direct mix of the Matrix Output Channels involved.

Tooltips have been included to easily understand each Input or Output Matrix Channel routing (Examples for a MIMO4040CDN unit, where the matrix routing and the AEC Room modules are shown, extensive to the MIMO7272DN model):

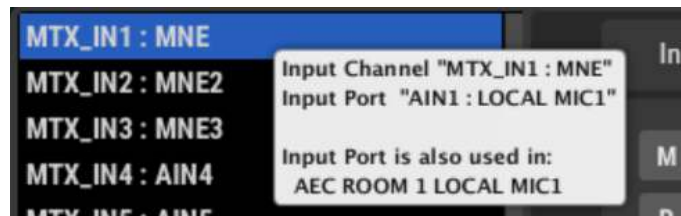
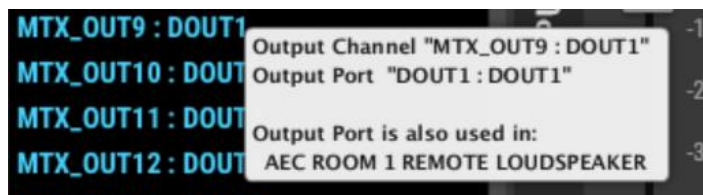
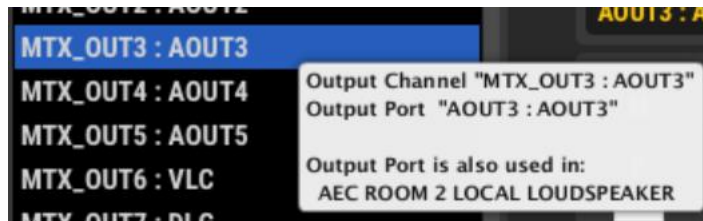

And a full summary of the Input and Output channels, including VU-meters and also very useful tooltips, has been added to the DEVICE section of the unit (example also for the MIMO4040CDN model, extensive to the MIMO7272DN model):

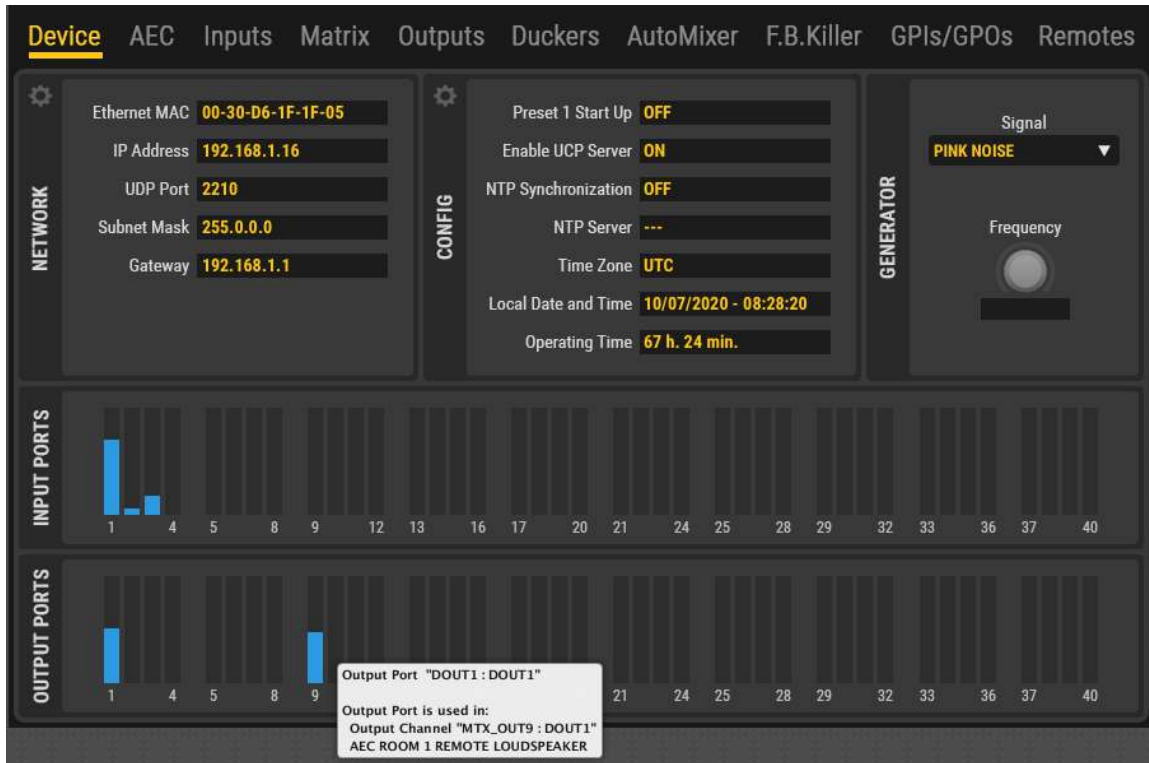

Note: the above routing structure has been implemented for both MIMO7272DN and MIMO4040CDN models).

The available processing for every INPUT channel is the same as the one available for the inputs of the MIMO88 model:



- INPUT preamp settings: sensitivity, GAIN, MONO/ST management, Phantom power ON/OFF. This option is available **just for the channels taking analogue Input Ports**, but not for the digital ones
- Time Delay, up to 1 second (=343 meters)
- Parametric EQ, 4 filters
- Noise Gate
- Compressor
- Level, MUTE and Polarity inversion controls
- Frequency Shifter (feedback effect reducer)

The available processing for every OUTPUT channel is the same as the one available for the outputs of the MIMO88 model:



- Level, SOLO, MUTE and Polarity inversion controls
- Extra + 6dB GAIN, MONO/ST management
- Crossover filters, LPF and HPF type
- Parametric EQ, 8 filters
- Time Delay, up to 1 second (=343 meters)
- Level limiter

NOTE (from v4 onwards): New EQ export / import feature that allows to export the EQ section from devices like MIMO family, NXA series, etc. to a *.eqs file that can be imported in other devices:

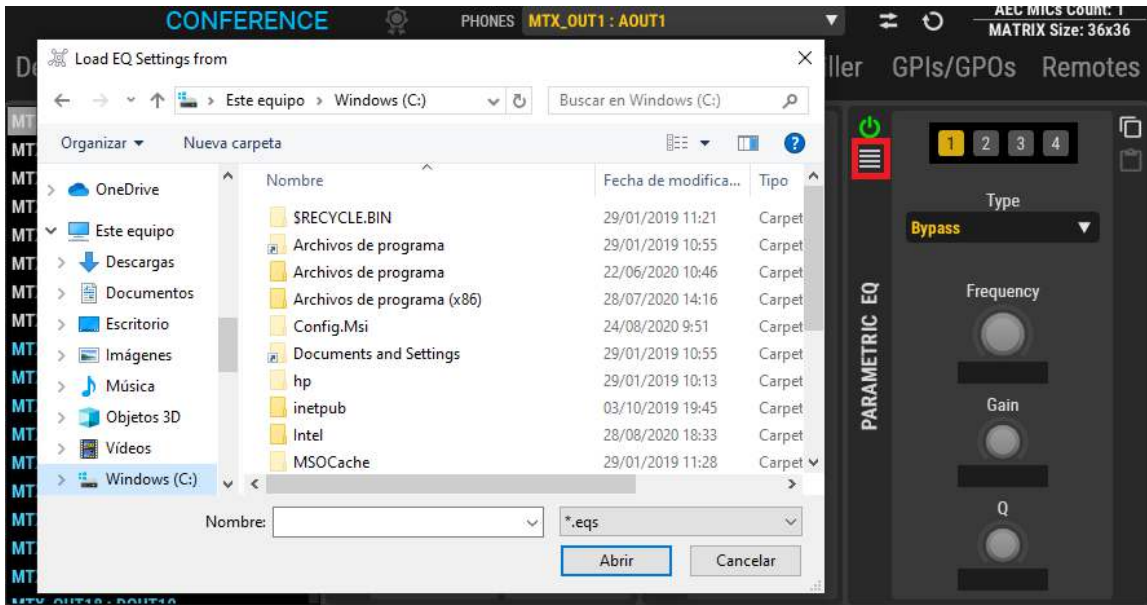

- It's available just when the EQ section is ON
- Exporting an EQ set with 8 filters (for instance, MIMO88 output EQ), for instance, to a device that supports 6 filters (like NXA units) will result in ignoring filters 7 and 8.

The MATRIX section of the MIMO7272DN in EclerNet Manager shows a view similar to this one:

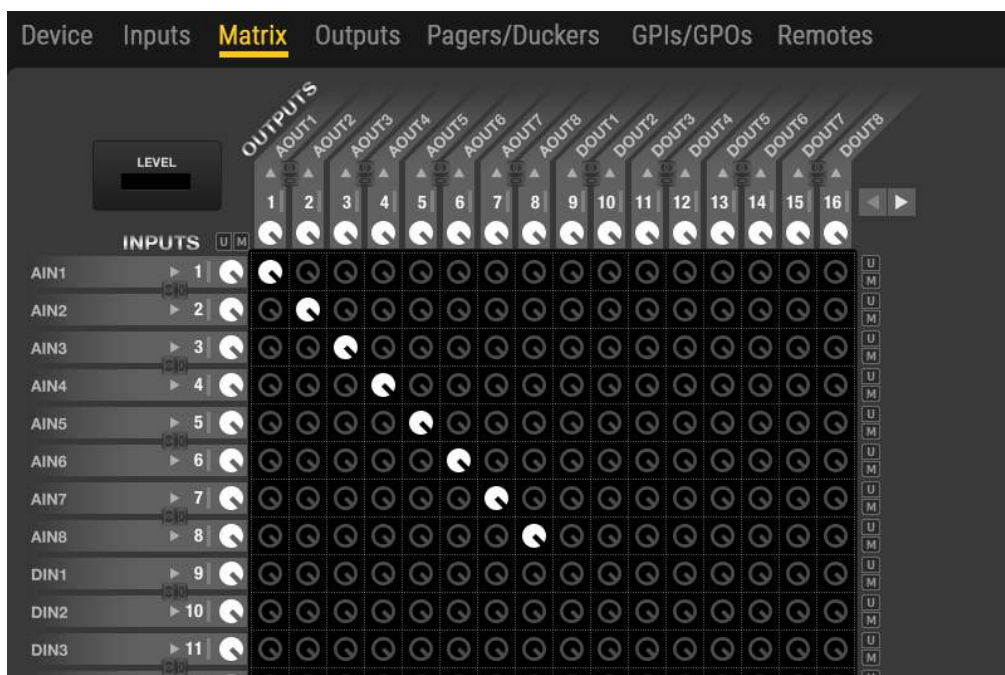

On the left side column, it shows the total of 64 audio INPUTS channels available in the matrix. The names of the inputs are the same defined as MTX_Inn: **custom label** in the INPUT section.

On the upper side line, it shows the total of 64 audio OUTPUT channels available. The names of the output are the same defined as MTX_OUTn: **custom label** in the OUTPUT section.

The matrix cross-points in between allow to route input channels (analogue or digital) to outputs channels (analogue or digital), including fully customisable switching and mixing capabilities for each individual audio output (analogue or digital).

Additionally, **40 matrix link groups** allow including inputs, outputs and/or cross-points into control groups that will manage all their included items simultaneously:

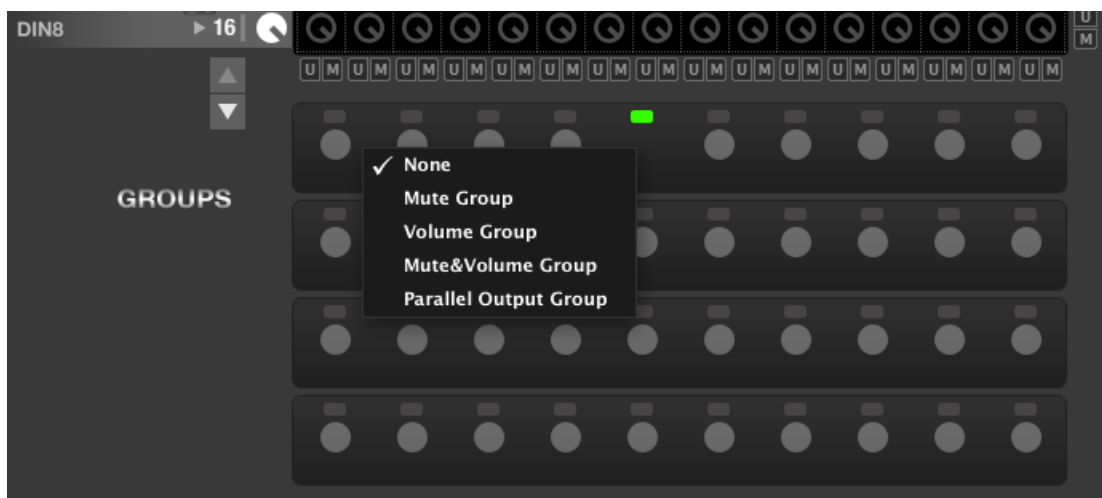

INPUTS, MATRIX and OUTPUTS sections for the MIMO7272DN include the same features and programming procedures as in the MIMO88 model. Look at [9.1. MIMO88 digital matrix](#) chapter to get into their details.

Like in the MIMO88, MIMO88SG and MIMO1212SG matrixes, all the configuration of the INPUTS, OUTPUTS and MATRIX sections, as well as the matrix link groups can be stored into each of the 99 available presets in the MIM7272DN memory:

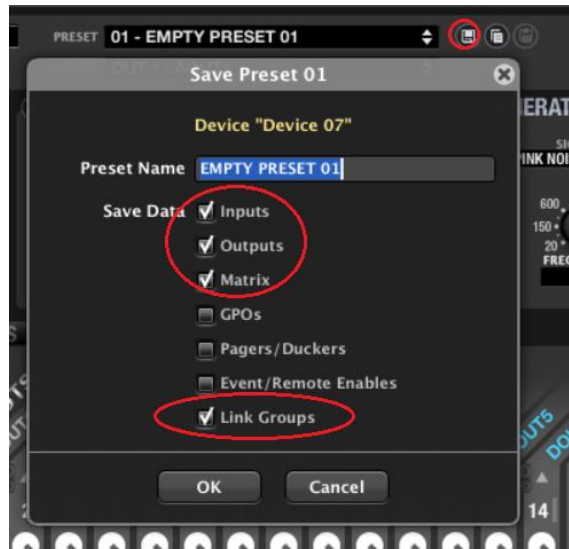

After a preset has been saved, with a given configuration saved in it, recovering the preset in the future means overwriting the current MIMO7272DN configuration with the “Save Data” options that were included in the preset at the time it was saved.

9.4.2. MIMO7272DN Pager / Ducker priority modules

The PAGERS/DUCKERS section of a MIMO7272DN device has the following appearance:

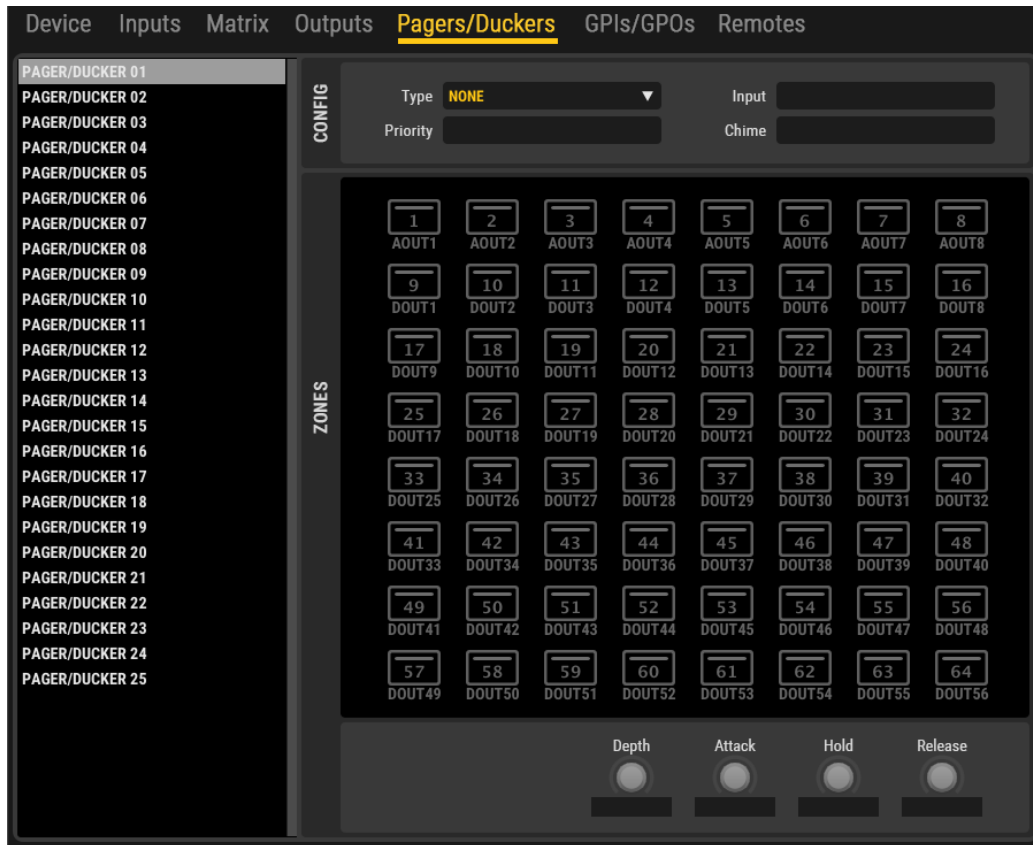

This section lets you configure the **25 priority audio modules**, based on the attenuation (or muting) of an audio signal by another signal, allowing the diffusion of messages or other audio content with priority over other audio signals. These modules are named "P/D module 1 " to "P/D module 25" (short for "Pager/Ducker Module 1, 2, 3, up to 25") and any of them can be configured as pager (real-time voice announcement for some destination zones selected through a PAGENETDN paging console, for example) or "ducker", "talkover" or "override" (an audio signal, when detected by its level exceeding a predefined threshold, has automatic priority over all other ones that are attenuated or muted in the selected destination zones.)

From this section it's not possible to operate PAGER modules as final user (selecting destination zones of the PAGER, activating the PAGE or DUCK function, etc.), but only to set performance parameters, priorities and enable/disable possible destination zones.

It is important to notice that the configuration of the PAGERS/DUCKERS section can be stored in Presets, so that different Presets define different destination zones and settings for these 25 modules.

The PAGERS/DUCKERS section of the MIMO7272DN includes the same features and programming procedures as in the MIMO88 model, with these differences:

- MIMO7272DN has 25 PAGER/DUCKER modules (4 in the MIMO88)
- The hardware paging console compatible with MIMO7272DN is the PAGENETDN model (eMPAGE / MPAGE16 models for the MIMO88)
- Priority audio, from a paging console or from any other audio source –like an automatic message player- can come from Dante™ or analogue origins (only analogue ones in the MIMO88)
- From EclerNet v6 onward, the duckers of MIMO7272DN and MIMO4040CDN, can also be selected as triggers for digital events; please refer to [digital event](#) section for further details.

See [MIMO88 PAGERS/DUCKERS section](#) chapter to get into further details.

9.4.3. MIMO4040DN NTP synchronisation service

Entering into the DEVICE -> CONFIG section of the MIMO7272DN, the following options are shown:

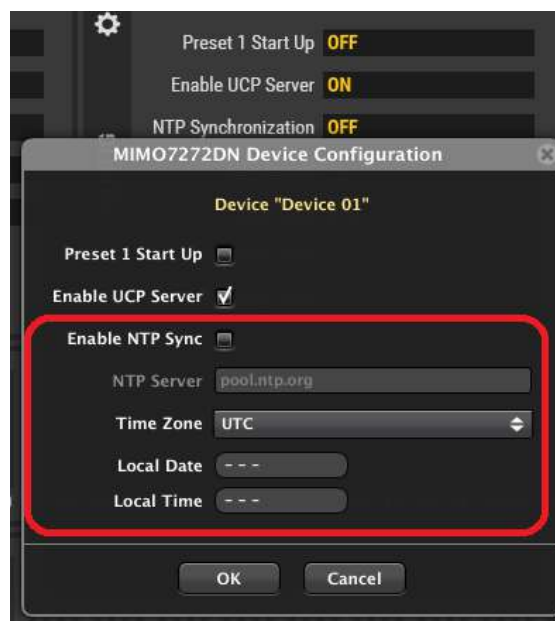

- **NTP Synchronization:** MIMO7272DN can automatically synchronize its clock with an NTP service (Network Time Protocol). To allow this happens, a valid NTP server must be entered in the NTP Server field (example: pool.ntp.org) and the desired Time Zone must be as well selected, according the location where the DUO-NET is going to be used
- Local Date and Time: internal clock settings, with a button (round dotted icon) to synchronize it with Windows clock (provided by the PC which runs EclerNet Manager).

When NTP service is disabled or not available, the unit will keep the internal RTC (real Time Clock) running, without being able to automatically synchronize with an external reference clock service.

9.4.4. MIMO7272DN UCP (User Control Panels) server service

The configuration window shows as well an option to enable / disable the internal UCP server:

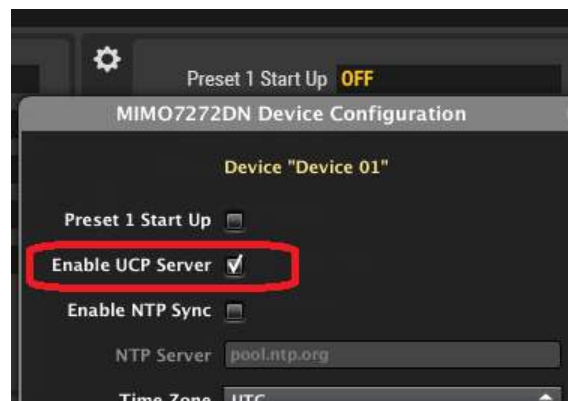

When this option is enabled, the ENM project which has been previously uploaded to the MIMO7272DN engine will be active, taking the control of all the EclerNet hardware units included in it (MIMO7272DN units, as well as other MIMO88, 88SG or 1212SG units, NXA units, DUO-NET PLAYERS, etc.), and serving the UCP panels as well included in the same project.

Note: see chapter [USER CONTROL PANEL \(U.C.P\)](#) for more details about UCP panels creation and features.

MIMO7272DN, like MIMO4040CDN, WPmSCREEN and WPNETTOUCH units, can store and execute a project previously created using EclerNet Manager, to perform as a web server for the UCPs included in this project. Therefore, no computer running EclerNet Manager is required when there's a MIMO4040DN in an EclerNet installation, with a project uploaded to its engine, and with the UCP server option enabled.

The procedure for transferring an EclerNet project to a MIMO4040DN and enable it as a UCP server is the following. Despite being an example with a MIMO4040DN unit, it is fully extensible to the MIMO7272DN model:

First you need to create or retrieve from the EclerNet Manager application (File -> Open) a project that includes EclerNet hardware and the configuration used in the installation (MIMO4040DN, MIMO88, MIMO88SG, MIMO1212SG, NXA units, etc.), as well as the desired UCPs, using the standard method described in the previous chapters of this manual. The following image shows a project that includes a MIMO4040DN, as well as other EclerNet devices, and several UCP panels. The green connection icons indicate that the MIMO4040DN is "online" and under the control of the computer running the project from the EclerNet Manager application, a proof that the network configuration of the computer and the MIMO4040DN device is suitable for a correct communication between them:



Note in the image above the Project Explorer window: it indicates that the project is running in **Local** mode, i.e. in the computer whose IP address is displayed (192.168.0.50 in this example), and not (yet) in a MIMO4040DN unit. In this state, the computer is acting as a UCP server.

It is recommended at this point to check that all the configuration for audio, events, GPIs, GPOs, etc. works properly with the associated hardware. In the image, the real audio activity can also be monitored on the level meters of the MIMO4040DN. Another important checking is related to the UCP panels design itself, using for that the project in Deploy mode and any networked UCP client (WPNETTOUCH / WPmSCREEN units, computers, iOS® or Android® devices), or the same computer with a web browser pointing to **localhost** address.

All of this guarantees that in the future, when the project runs on the MIMO4040DN as the UCP webserver, everything will work as expected:

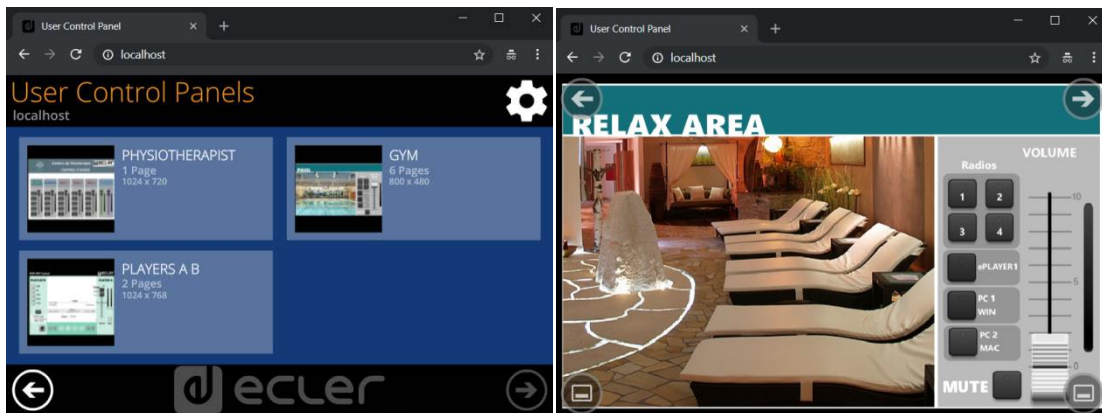

After the above checks, the procedure for transferring the project to a MIMO4040DN unit is the following:

If the computer and the MIMO4040DN have been previously connected to the same local network, with compatible IP addresses and masks, access the **Connect and send** option in the **UCP Server** menu:

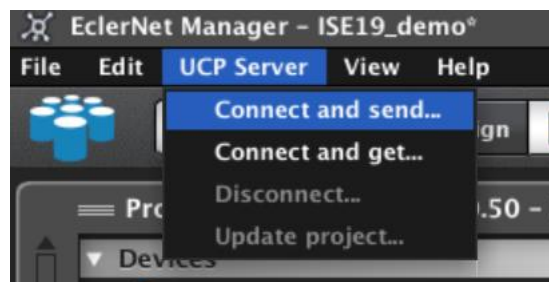

A window will appear to allow to select the target MIMO4040DN unit you want to transfer the project to, among a list of potential EclerNet hardware units, automatically detected, which are capable to behave as UCP webserver (like MIMO4040DN, WPNETTOUCH or WPmSCREEN models):

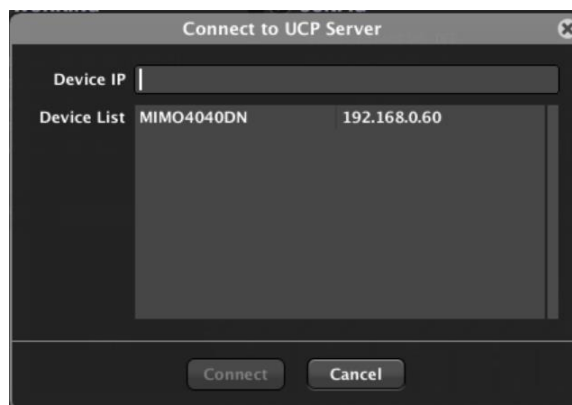

Once the transfer is complete, the EclerNet Manager application will indicate that the project displayed on screen is the one running now in the MIMO4040DN:

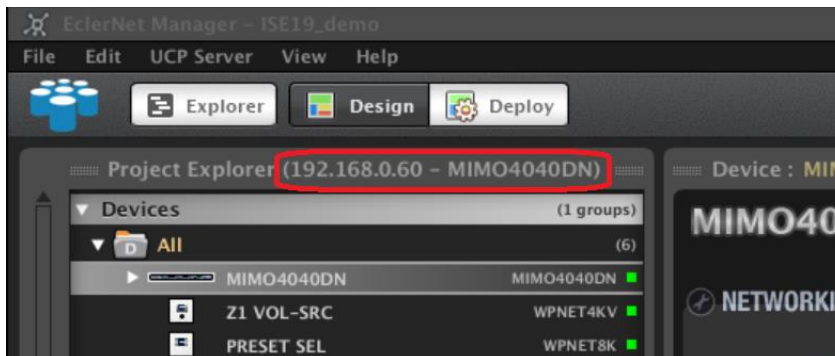

In this state it is possible to edit the project currently visible on screen and then to update it in the MIMO4040DN (Update project):

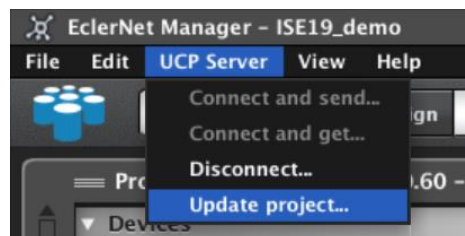

The last step is to disconnect the computer from the MIMO4040DN, with the aim to leave this MIMO4040DN as the device running the project:

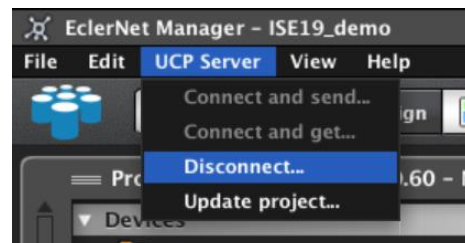

And, after this, a confirmation of the project update in the MIMO4040DN is requested:

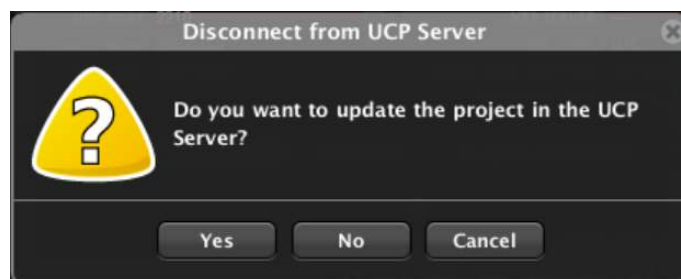

Then a message is displayed during the transfer of the project to the MIMO4040DN:

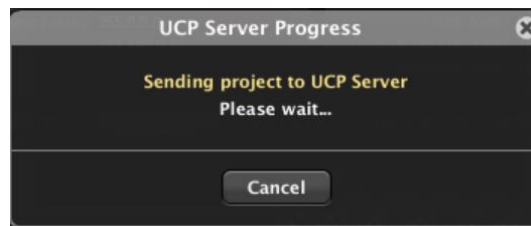

Two actions take place after the disconnection:

1. The EclerNet Manager application in the computer restarts the **Local** mode, but this time running a new and totally empty project (New Project), so that it doesn't interfere with the MIMO4040DN's project by both trying to take control of the same hardware in the installation:

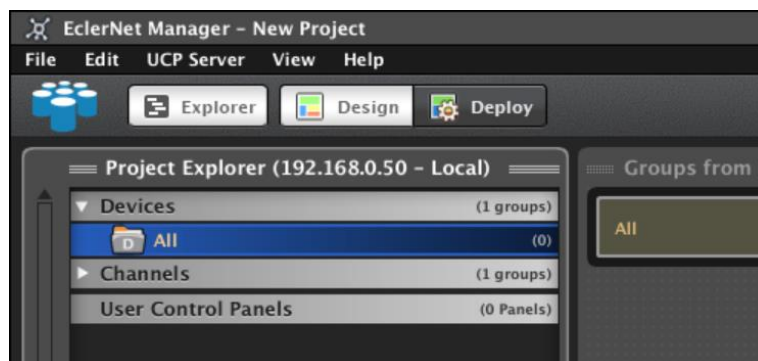

- The MIMO4040DN unit hosts and runs the project recently transferred, and enables the UCP server function, serving the panels it contains

From that moment on, any UCP client, including WPmSCREEN / WPNETTOUCH units, computers and Android® or iOS® devices, can connect to the MIMO4040DN, as it will be working as a UCP server:

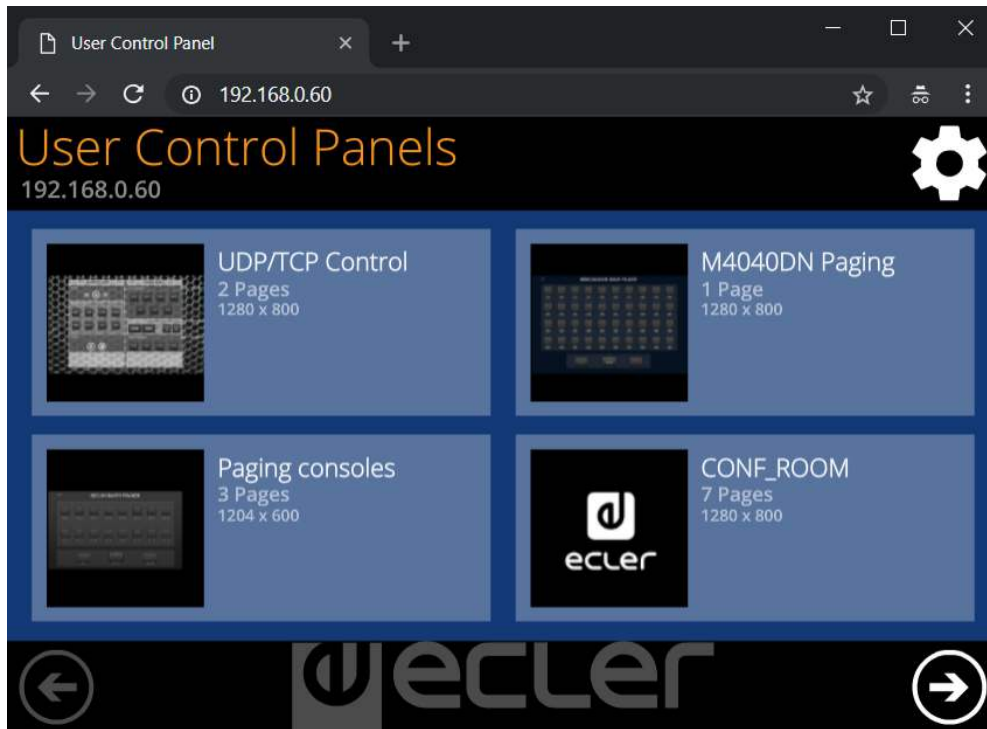

9.4.5. MIMO7272DN REMOTES section

REMOTES section allows to configure the different hardware / software remote controls that can be used for the end-user control functions of a MIMO7272DN unit.

These are the possible types of remote controls that can be linked to a MIMO7272DN unit:



The first two types are shared with the rest of MIMO matrixes:

- ANALOG type: see MIMO88's chapter **Configuring an ANALOG-type remote control** for the full programming guide
- VIRTUAL selector type: see MIMO88's chapter **Functions assignment in the UCP** for the full programming guide

The rest of remote controls compatible with MIMO7272DN (and MIMO4040CDN as well) are all digital wall panels, belonging to the WPNET series, 3 hardware models: WPNET4KV, WPNET8K and WPNETEX models.

They allow performing control functions on a MIMO7272DN unit, like audio sources selection, presets selection, volume control, etc.

Even they are just 3 different hardware models, they can be used or combined in several ways. That's why in the list some additional references appear: WPNET12K, WPNET4K MULTI and WPNET12K MULTI. Read this chapter for the details of each and every one of the possible uses of them.

These 3 models have the following main characteristics:

- PoE DC supply (Power over Ethernet) or external (optional) power supply, WP-PSU model
- Ethernet communication interface, RJ45 connector
- LCD screen, 128x128 pixels
- Digital rotary control (encoder) + 4 programmable keys: 4KV and EX models
- 8 programmable keys: 8K model

Note: see WPNET series user manual for further details about their installation, connection and user management

Once a WPNET unit is connected to the same LAN (Local Area Network) as the MIMO7272DN unit, it will appear, automatically discovered, as an Online and Unused Device in the Project Explorer helper window, similar to this image (including one unit of each model):

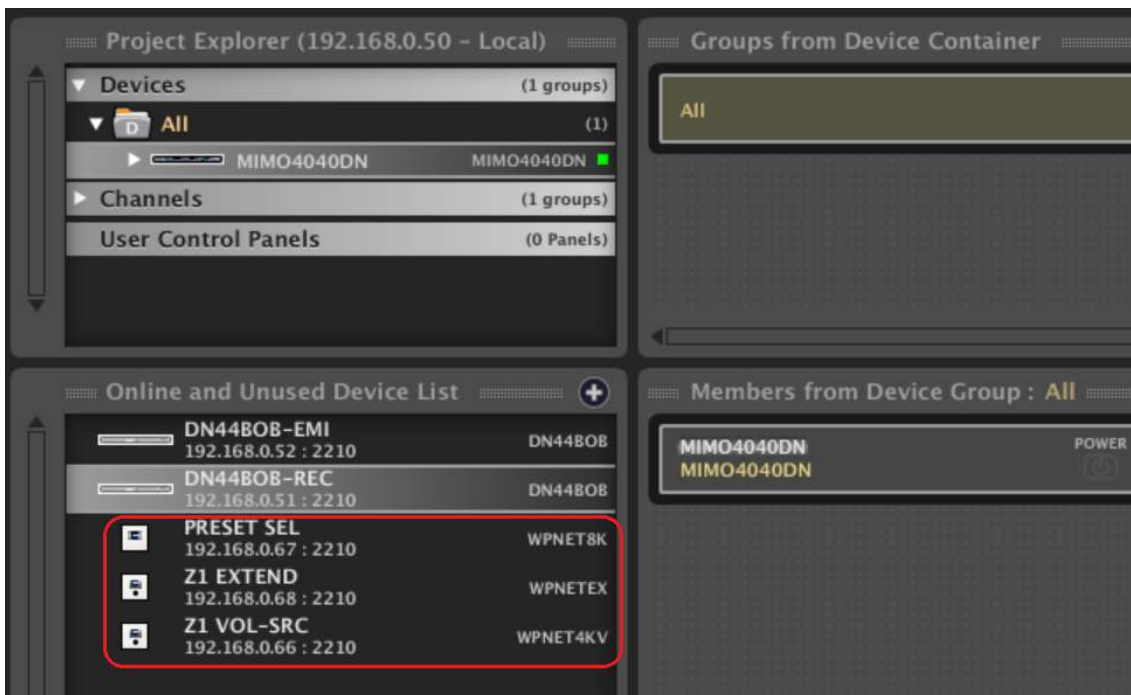

If a device has a network configuration (IP address, Subnet Mask and Gateway) compatible with the IP range of the MIMO7272DN unit in the project, it can be added to it:

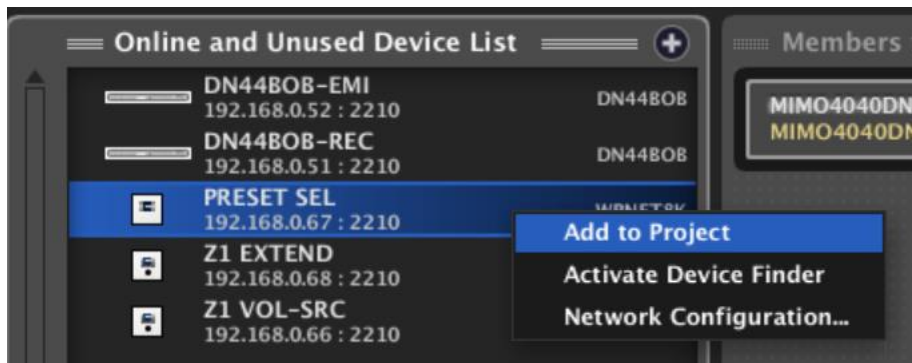

And then, entering into the REMOTES section of the MIMO7272DN, the WPNET remote control can be added to its REMOTE LIST and then configured in detail:

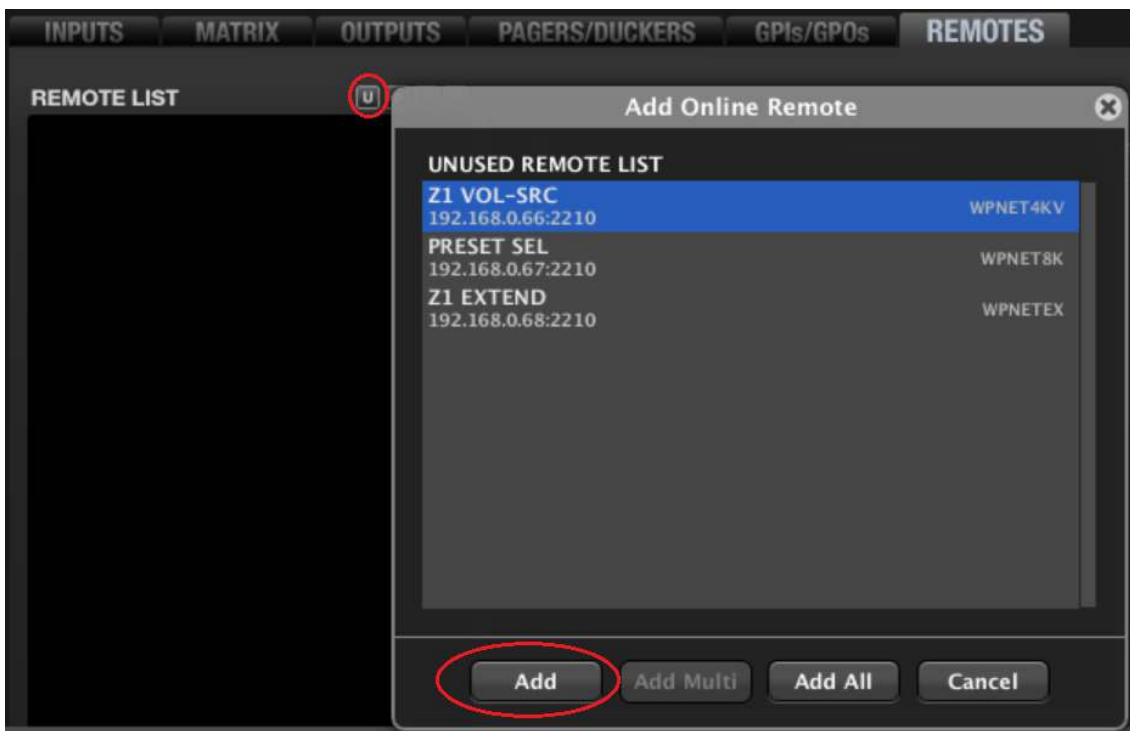

9.4.5.1. Configuring a WPNET4KV unit

Click in the **Change Configuration** icon to enter into the unit's detailed configuration:



WPNET4KV options for remote control are:

- Audio sources selection for a given output (zone), from a predefined list of options, or **Inputs Carrousel**
- Preset selection (recall), from a predefined list of options, or **Presets Carrousel**
- Volume / MUTE control for a given input, output, matrix crosspoint or selected source (X-Focus)

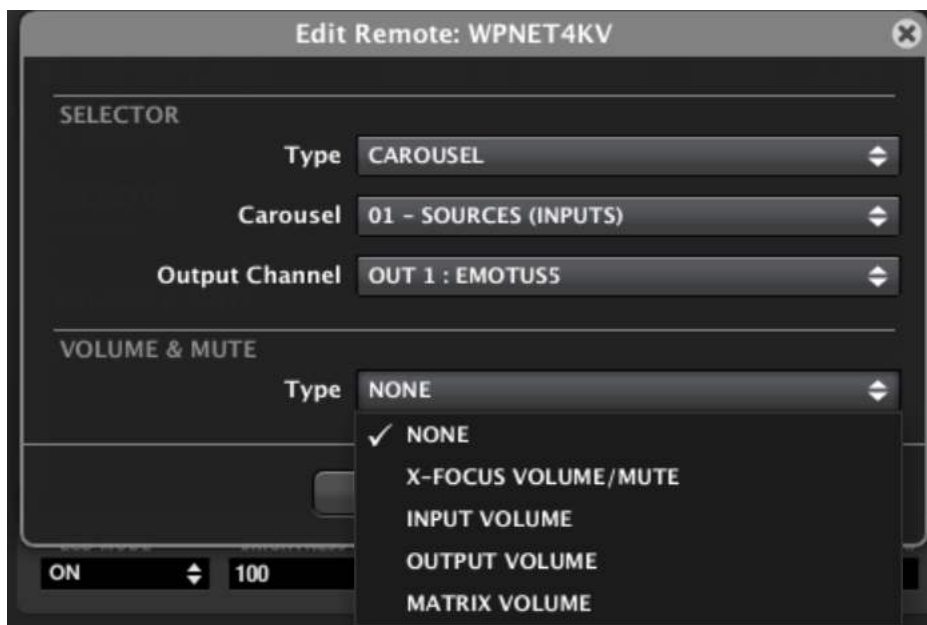

Note: see chapter [Carousel lists for MIMO88](#) for further information about Inputs and Presets Carrousel's creation and management.

Some additional options for the WPNET unit under setup appear at the bottom line of its configuration window:

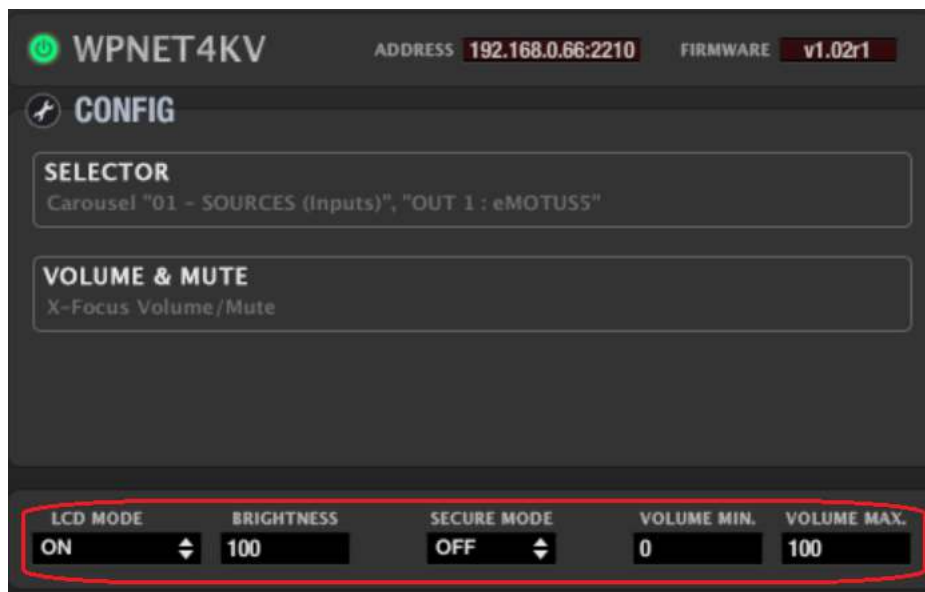

- **LCD mode (ON / DIMMED / OFF):** defines the LCD backlight status when the unit enters into idle mode, after several seconds without user interaction
- **Brightness:** LCD backlight level
- **Secure mode (ON / OFF):** when ON, two consecutive key press actions (select + confirm) must be applied to effectively activate the selection action of a given control key
- **Volume MIN / MAX:** defines the effective volume range that the encoder can handle over the volume under its control

Once programmed, the WPNET4KV can handle source or preset selection and volume / MUTE control, according the texts shown in the text fields in the LCD and using the 4 direct selection keys and the rotary encoder:

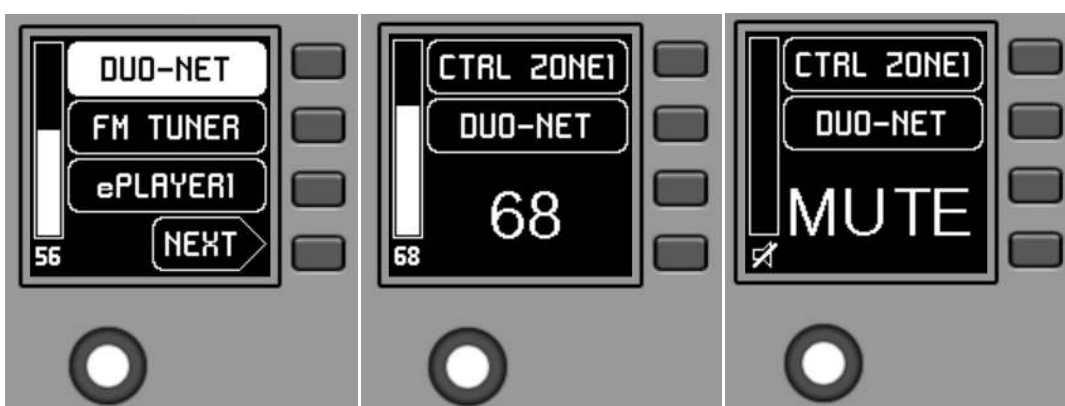

Note: see WPNET series user manual for further details about WPNET4KV management.

9.4.5.2. Configuring a WPNET8K unit

Click in the **Change Configuration** icon to enter into the unit's detailed configuration:



WPNET8K options for remote control are:

- Audio sources selection for a given output (zone), from a predefined list of options, or **Inputs Carrousel**
- Preset selection (recall), from a predefined list of options, or **Presets Carrousel**

Note: see chapter **Carousel lists for MIMO88** for further information about Inputs and Presets Carrousels creation and management.

Some additional options for the WPNET unit under control appear at the bottom line of its configuration window:

- **LCD mode (ON / DIMMED / OFF):** defines the LCD backlight status when the unit enters into idle mode, after several seconds without user interaction
- **Brightness:** LCD backlight level
- **Secure mode (ON / OFF):** when ON, two consecutive key press actions (select + confirm) must be applied to effectively activate the selection action of a given control key

Once programmed, the WPNET8K can handle source or preset selection, according the texts shown in the text fields in the LCD and using its 8 direct selection keys:

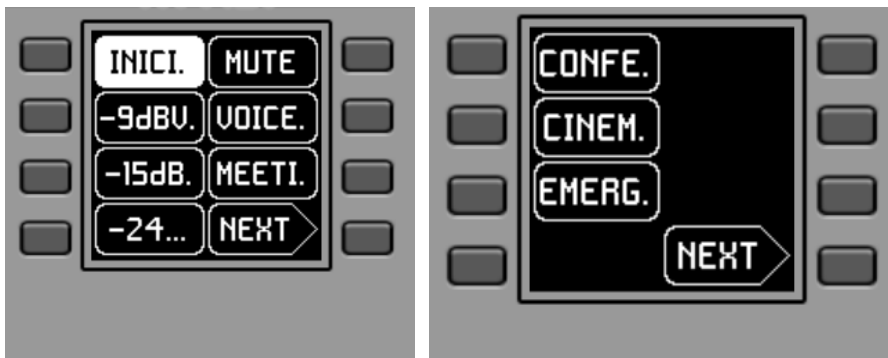

Note: see WPNET series user manual for further details about WPNET8K management.

9.4.5.3. Configuring a WPNETEX unit

Click in the **Change Configuration** icon to enter into the unit's detailed configuration:

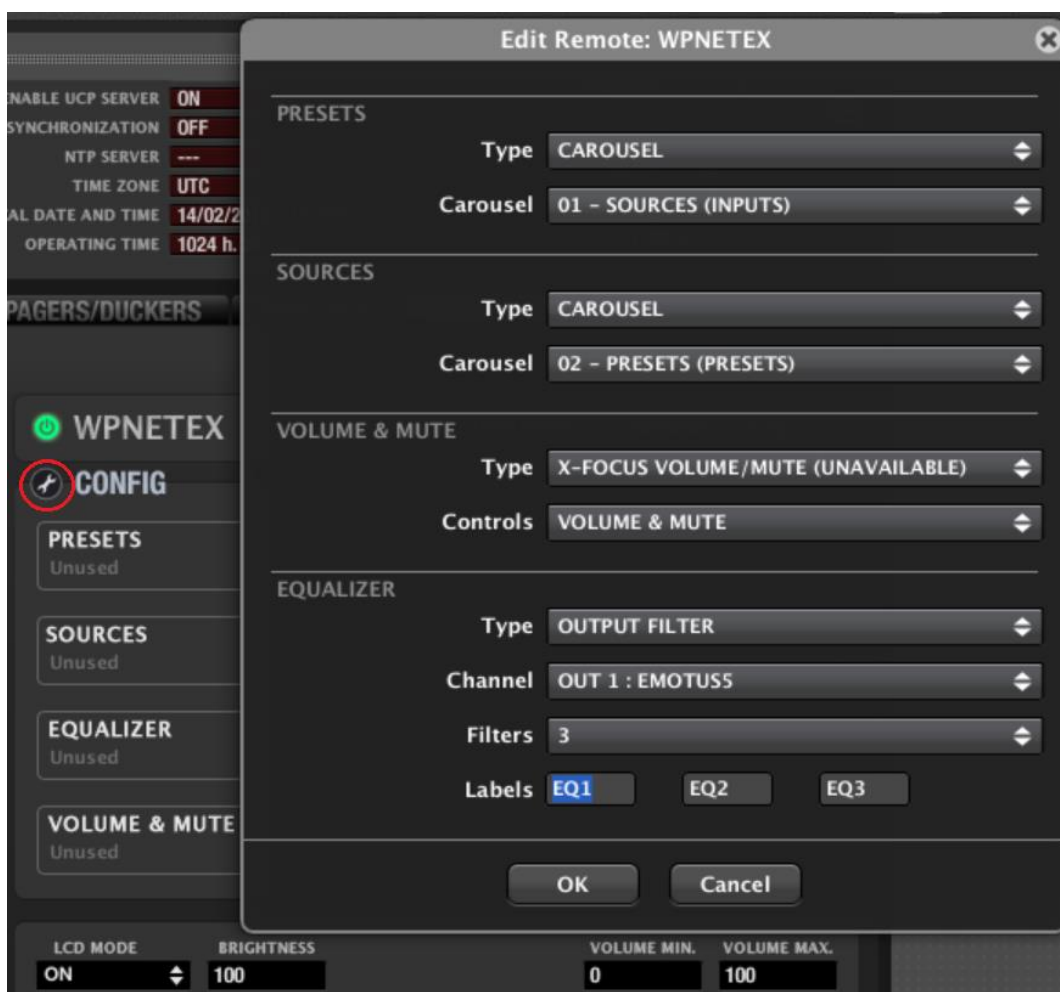

WPNETEX options for remote control are:

- Audio sources selection for a given output (zone), from a predefined list of options, or **Inputs Carrousel**
- Preset selection (recall), from a predefined list of options, or **Presets Carrousel**
- Volume / MUTE control for a given input, output, matrix crosspoint or selected source (X-Focus)
- EQ control: gain control of up to 3 EQ filters, previously defined (frequency and Q factor) in an input or output of MIMO4040DN

These 1, 2 or 3 EQ filters coincide with filters 1, 2 and 3 (the first 3 ones) of the input or output under control in the MIMO4040DN unit. In the next example, for output #1:

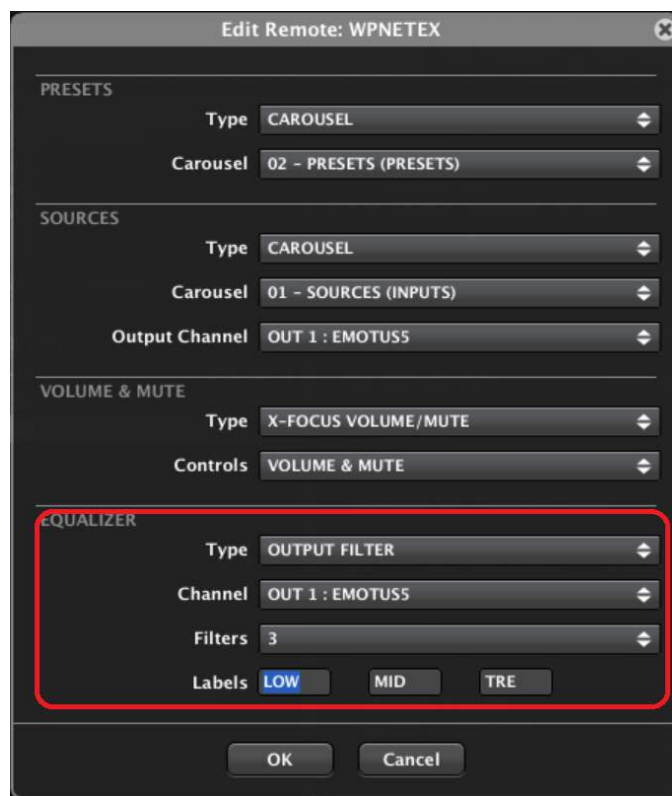



Note: see chapter [Carousel lists for MIMO88](#) for further information about Inputs and Presets Carrousel's creation and management.

Some additional options for the WPNET unit under control appear at the bottom line of its configuration window:

- LCD mode (ON / DIMMED / OFF): defines the LCD backlight status when the unit enters into idle mode, after several seconds without user interaction
- Brightness: LCD backlight level
- Volume MIN / MAX: defines the effective volume range that the encoder can handle over the volume under its control

Once programmed, the WPNETEX can handle source and/or preset selection, volume / MUTE control and EQ control (up to 3 bands), according the texts shown in the text fields in the LCD and using the 4 keys and the rotary encoder:

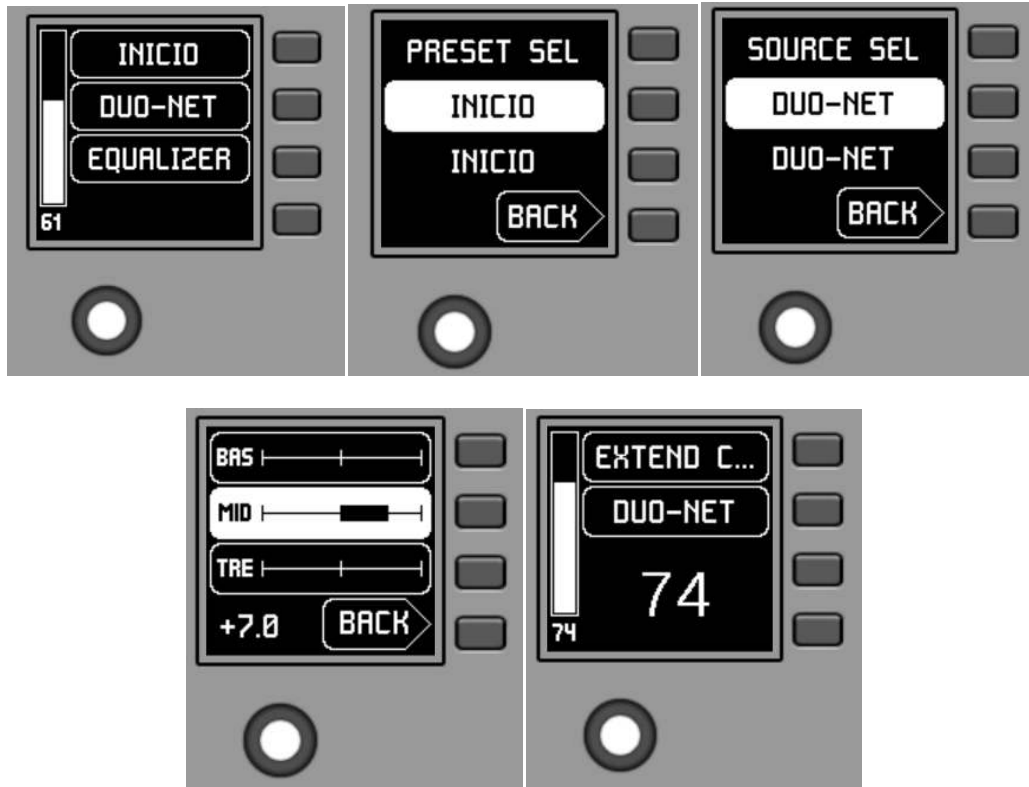

Note: see WPNET series user manual for further details about WPNETEX management.

9.4.5.4. Configuring a WPNET12KV unit

It is possible to combine a couple of adjacent WPNET4KV and WPNET8K hardware digital controls, converting them into a new, bigger WPNET unit, **WPNET12KV**, including 12 selection keys, one rotary encoder and a wider range of on-screen information and selection options with direct keys press actions.

Click in the **Change Configuration** icon to enter into the unit's detailed configuration:



WPNET12KV options for remote control are:

- Audio sources selection for a given output (zone), from a predefined list of options, or **Inputs Carrousel**
- Preset selection (recall), from a predefined list of options, or **Presets Carrousel**
- Volume / MUTE control for a given input, output, matrix crosspoint or selected source (X-Focus)

Note: see chapter [Carrousel lists for MIMO88](#) for further information about Inputs and Presets Carrousel's creation and management.

Some additional options for the WPNET unit under control appear at the bottom line of its configuration window:

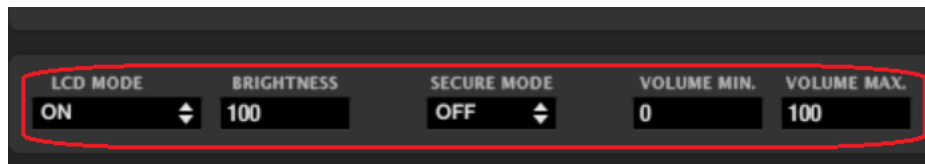

- LCD mode (ON / DIMMED / OFF): defines the LCD backlight status when the unit enters into idle mode, after several seconds without user interaction
- Brightness: LCD backlight level
- Secure mode (ON / OFF): when ON, two consecutive key press actions (select + confirm) must be applied to effectively activate the selection action of a given control key
- Volume MIN / MAX: defines the effective volume range that the encoder can handle over the volume under its control

Once programmed, the WPNET12KV can handle source or preset selection and volume / MUTE control, according the texts shown in the text fields in both LCD screens, and using the rotary encoder and the total of 12 direct keys:

The control and management possibilities of this WPNET12KV unit are identical as the ones available for the WPNET4KV unit, in this case extending the direct selection keys from 4 to 12 and the selection options shown on screen as well to 12

Note: see WPNET series user manual for further details about WPNET12KV management.

9.4.5.5. Configuring a WPNET4KV or WPNWT12KV in MULTI mode

There is an additional working mode for a WPNET4KV or WPNET12KV control panels, named **MULTI**. Under this mode, one hardware units really behaves as a multi-zone controller. A WPNET4KV / 12KV hardware unit working in MULTI mode will have a customized “remote panels carousel list” available, a list including some single WPNET4K or WPNET12KV units (respectively) already created in the project, being those ones real (hardware, = physical) or virtual (just existing in the project, no hardware linked). The WPTNET4KV / 12KV MULTI can select any of those WPNET4KV /12KV individual units in its own carousel list to impersonate it, take its role, automatically behaving as a clone of a WPNET4KV / 12KV single unit. This way a WPNET4KV / 12KV hardware unit, programmed as MULTI, can be flexible and take the control of any zone, as well as being a preset recaller.

Note: the following explanation and examples are focused on the WPNET4KV MULTI setup, but the procedure will be identical for a WPNET12KV unit.

At the time you add a new WPNET4KV unit to the REMOTES LIST in your MIMO7272DN device, you can decide that it will work as a WPNET4KV MULTI unit:



And, adding more WPNET units to your project, you will end up with a list of them, similar to this one:

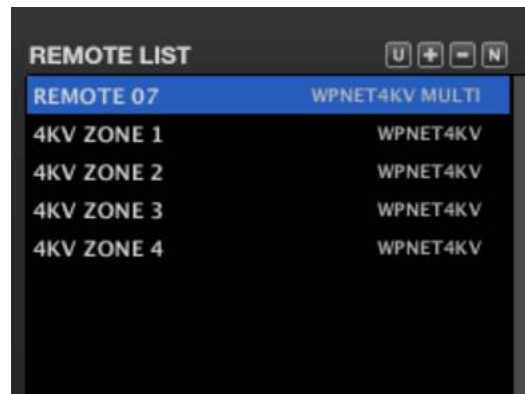

Some of the above WPNET4KV individual units will be linked to real hardware WPNET4KV devices, and some others will just be virtual (software) ones, included in the project but with no hardware impersonation. But all of them will be programmed individually, as single zone controls, with sources selection, or as presets selectors, and/or volume controllers.

One WPNET4KV MULTI unit, which does have linked a real hardware WPNET4KV unit, will be programmed just adding any of the previous WPNET4KV single units to a list. This list contains, then, the carousel of possible “roles” that a WPNET4KV MULTI can take when entering into its REMOTE CONTROL SELECTION mode:

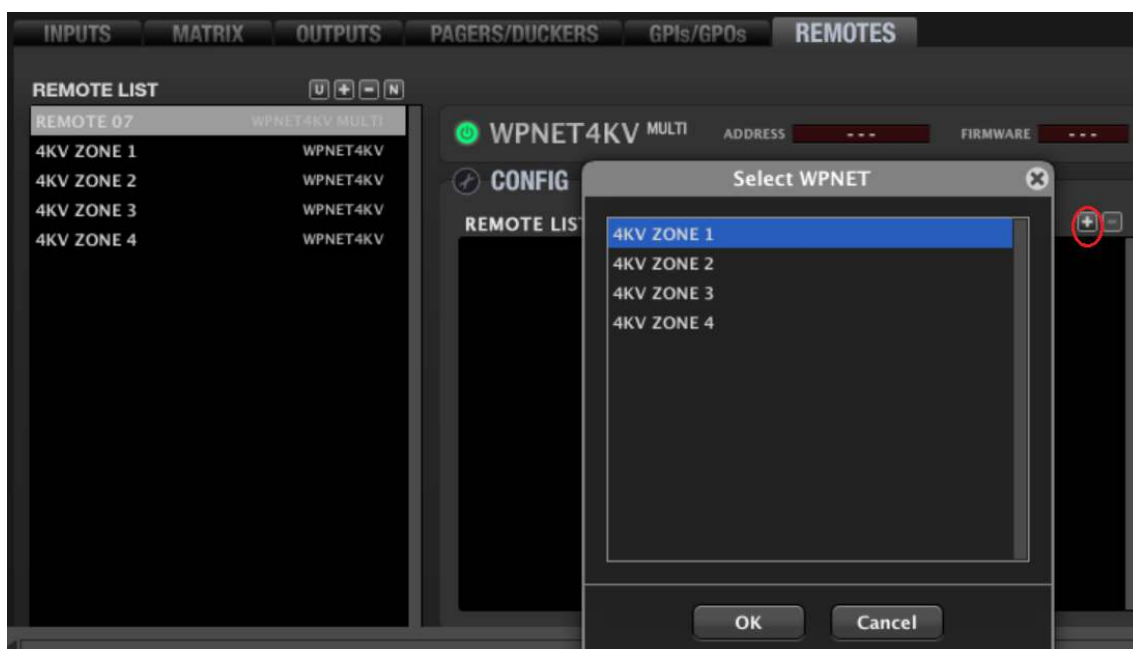

... double click on the desired items under the “Select WPNET” options until the WPNET list is completed as desired, and modify the position of each remote in the list, as this will be the order they’ll appear in the WPNET4KV MULTI LCD unit’s display, as a carousel list:

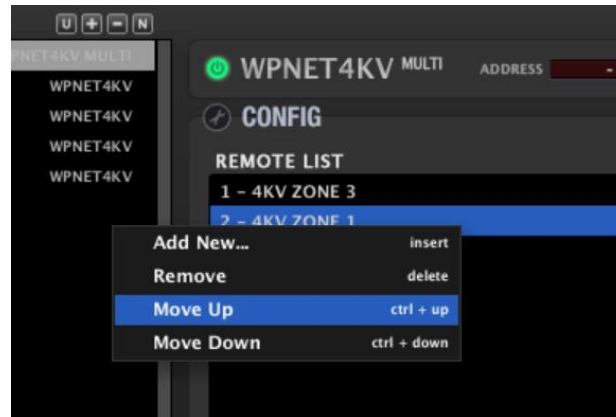

Once programmed, a WPNET4KV MULTI hardware device shows the control features of one of the individual WPNET4KV units in its list, the one currently selected:

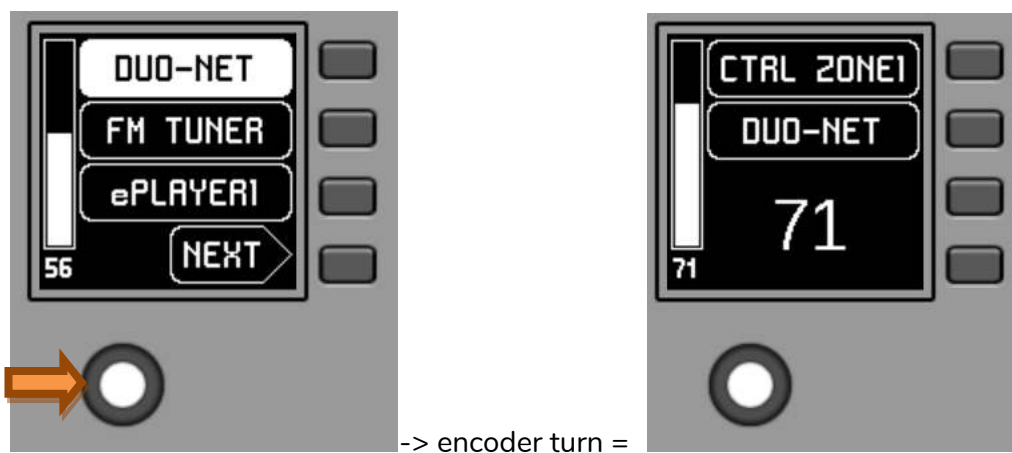

In the above example a WPNET4KV MULTI is taking the role of an individual WPNWT4KV unit named “CTRL ZONE1”, and showing its control options.

A long encoder press (> seconds) gives access to the menu that allows to take the control of other WPNET4K individual units included in its list:

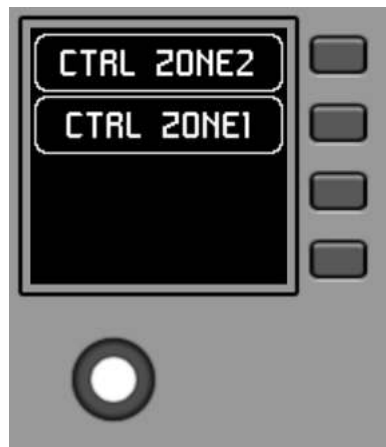

Note: to get further information about WPNET4KV / 12KV controls working in MULTI mode, and how to use them once programmed, please refer to WPNET series user manual.

9.5 MIMO4040CDN (C = CONFERENCE), Dante™ matrix for conference with AEC

9.5.1. MIMO4040CDN Introduction

The new MIMO4040CDN (also called MIMO4040DN CONFERENCE) has been specially designed for conferencing applications and generally for all the applications that require automatic mixing of microphone signals and / or feedback cancellation (audio feedback or Larsen effect) and acoustic echo cancellation (AEC).

MIMO4040CDN shares many of the MIMO4040DN (discontinued on March 2021 / EclerNet Manager v6.01r3) and MIMO7272DN standard functions:

- Inputs and outputs routing and processing (levels, EQ, noise gate, etc.),
- Management of priority signals (evacuation, emergency)
- Management of GPI and GPO control ports
- Management of digital and analogue remote controls (WPNET & WPa series, etc.)
- Presets management
- Events management
- Programming and control using EclerNet Manager application software
- Remote control via TP-NET, Ethernet or RS-232 protocol (Third-Party Protocol)
- Remote control via UCP (User Control Panels)

And MIMO4040CDN has some differences, or characteristics of its own, compared to other EclerNet matrixes:

- **Flexible Signal Routing:** as in the case of the MIMO727DN model.
- **AEC Section:** This section includes 4 Acoustic Echo Cancellation modules suitable for up to 4 different conference rooms with a maximum of 8 microphone inputs in total (depending on the software license purchased), freely assignable to each room along with 2 audio local media inputs, non-microphonic.
- **DUCKERS Section:** PAGER modules are removed and 25 DUCKER modules are still kept and enabled for the automatic management of emergency / evacuation signals
- **AUTOMIXER Section:** new section for the configuration of the automatic mixing
- **FEEDBACK KILLER Section:** new section for the configuration of the 2 available modules dedicated to feedback cancellation, each one of them including 8 notch filters with automatic adjustment

Both AUTOMIXER and FEEDBACK KILLER settings can be stored and retrieved using presets. In this way, different presets can store different configurations of these two sections.

AEC configuration parameters are general project settings configured for each AEC ROOM: number of Local Microphones used in each room, number of Local Media and Local reinforcement through loudspeakers used in each room (ON / OFF). These settings are not affected by presets save & recall, but the ON/OFF status of each AEC Room can be still stored and recalled based on presets:

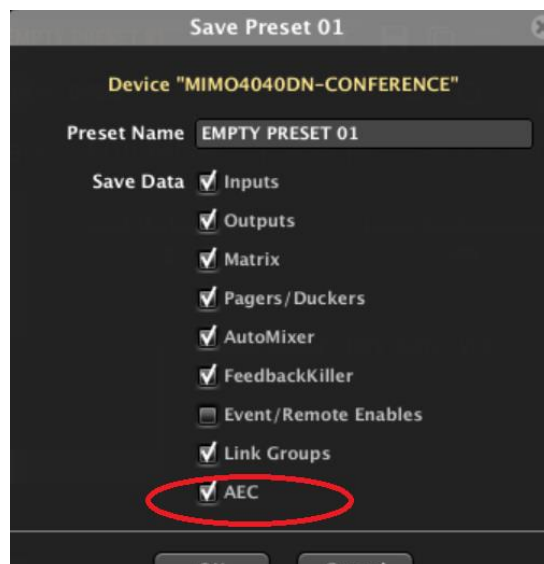

The following paragraphs describe the general operation of the MIMO4040CDN. Given that many of the features available in the MIMO4040CDN are common to the ones in the standard MIMO4040DN / MIMO7272DN, the next sections will especially detail the differences with the standard version, as well as how to operate the new features included in the MIMO4040CDN version: AEC, AUTOMIXER, DUCKER and FEEDBACK KILLER. It is highly recommended to also refer to chapter [EclerNet COMPATIBLE DEVICES: MIMO88 digital matrix](#) for in-depth understanding of processing and control features and capabilities that are common to MIMO88 and MIMO88CONF.

9.5.2. AEC License Activation

If you want to use the acoustic echo cancellation function, it may need a paid license depending on the maximum number of AEC microphones required in the project.

Note: In offline mode the AEC modules can be configured freely, but as soon as a real HW device is attached online to the project, AEC modules will be disabled unless there is a valid AEC license loaded into the HW unit. An AEC license is personal, always linked to just one particular HW device, identified by its Hardware ID code (HID)

License activation Panels requires the following simple steps:

1. Once the device has been added to the project and it appears as online in the Project Explorer window, double click on MIMO4040CDN (o MIMO4040DN CONFERENCE) in order to open the Device control window.
2. Click on the Edit Device Licenses like indicated in the picture below:



- The Edit Licenses window will show a HID code that is required for the licence purchasing, or it will be enough to identify the MAC ADDRESS of the unit, shown in the upper window as Ethernet MAC (*):

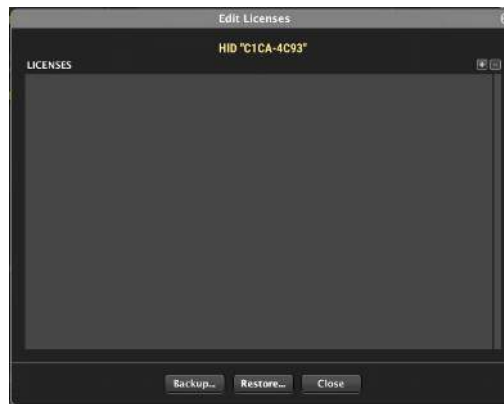

(*) Contact your Ecler official distributor to determine the procedure to purchase AEC licenses

- After the purchase, and once having received the license file, click on the Add License button at the top right, select the .lic file corresponding to the license and open it.

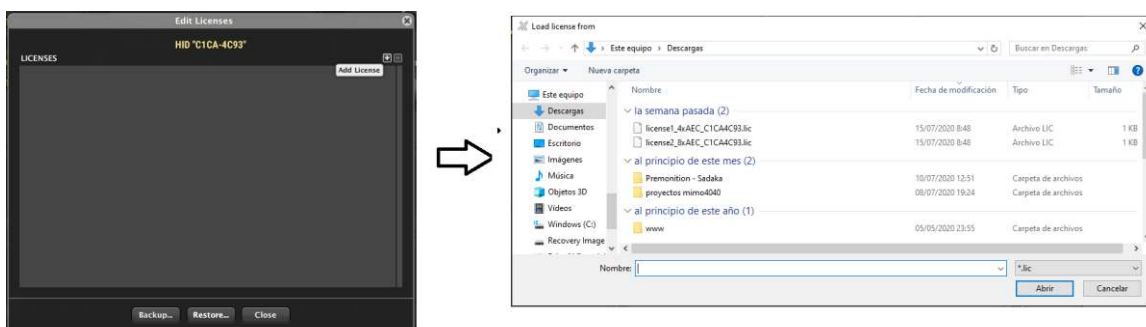

- The license in use automatically appears in the License list in white colour, meaning this that it has been successfully validated and activated in the MIMO4040DN HW unit, and is now ready to use:

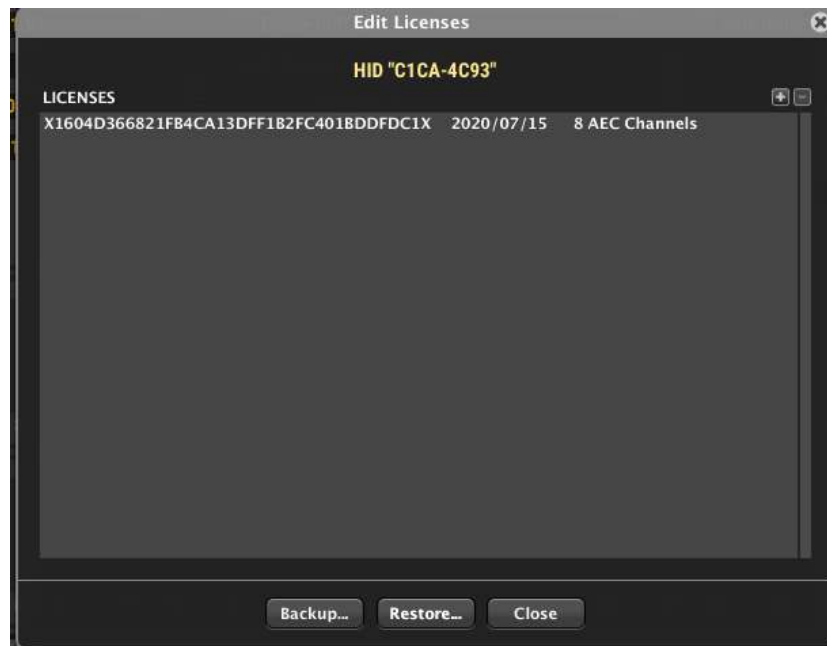

- Important:** In case of factory defaults procedure to the MIMO4040CDN HW unit, or when the device needs to be sent to the technical service, the license can be saved locally with the Backup button and later restored to the same HW unit with the Restore button.

9.5.3. AEC Section (Acoustic Echo Cancelling)

The great novelty that distinguishes the MIMO4040DNCONF matrix, is the presence of the new acoustic echo cancellation modules.

These modules allow you to manage up to 8 microphones that can be distributed as desired among up to 4 conference rooms, each one with customized settings.

Let's go into detail in the terminology of the modules and the audio signals involved in the AEC processing.

In the lower right corner of ENM screen, an icon with an "A" is available to show a graphical outline which will help to understand the involved audio signals and their routing:



Once the button is pressed, a window will open showing the conceptual scheme of the AEC with the terminology used in EclerNet:

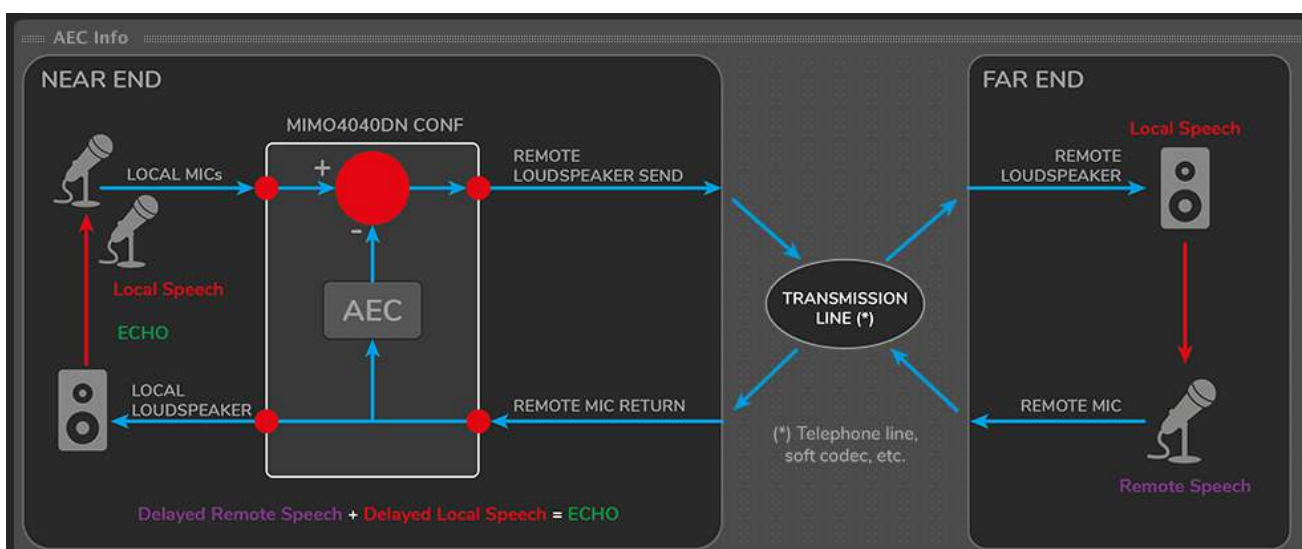

In a conferencing application we typically have two remote locations that establish a call session and keep a live conversation. In conferencing jargon, one is called NEAR END (this is where you and your MIMO4040CDN are physically, in your conference room) and a remote one that is called FAR END (where your interlocutor is located, at the other side of the transmission line). The goal of an AEC processing running in your MIMO4040CDN is that the FAR END gets the audio from the NEAR END free of echo artefacts, clear and intelligible, in order to keep a natural and comfortable conversation session.

The MIMO4040CDN in the NEAR END (your conference room) will need to get the audio from some local microphones and send it to the FAR END, once processed by the AEC algorithm. At the same time, the audio from the distant conversation (FAR END) must be received in the MIMO4040CDN, processed and played through local loudspeakers in the NEAR END room.

The transmission line in between NEAR and FAR END can be a telephone line, a soft codec application (Zoom, Skype etc..) and, depending on the applications, different connection methods may be used for the audio signals of the the REMOTE LOUDSPEAKER SEND and REMOTE MIC RETURN between the MIMO4040CDN and the transmission line can be:

- **Analogue:**
 - Using analogue INs / OUTs of the MIMO4040DN CONF, connected to a phone or conferencing terminal with analogue audio INs and OUTs
 - Using analogue INs / OUTs of the MIMO4040DN CONF, connected to a USB audio interface (or soundcard). The interface converts the analogue audio channels into USB audio channels in the computer, which are then available for the soft codec / softphone apps as well.
- **Digital via Dante™ protocol:** whenever the transmission device admits Dante INs and OUTs, the Dante INs and OUTs in the MIMO4040DN CONF can be used for this purpose, at least, in two possible ways:
 - A computer running an enabled Dante Virtual Soundcard (DVS) license from Audinate. The DVS Dante channels get/send Dante audio from the MIMO4040CDN, which can be used directly in soft-codecs and softphone apps as their audio input and output signals.
 - A computer with a Dante to USB adapter connected. The Dante channels sent/received from the MIMO4040CDN are converted and available as USB audio channels in the computer, then available for the soft codec / softphone apps as well.

9.5.3.1. AEC structure

Once the AEC configuration window has been opened, the first thing to do is defining the number of microphones for each of your conference rooms just pressing the AEC ROOM CONFIGURATION button indicated below. Remember that the maximum number of microphones processed by the acoustic echo cancellation algorithm can be 8 in total, distributed in up to 4 rooms (AEC Rooms).

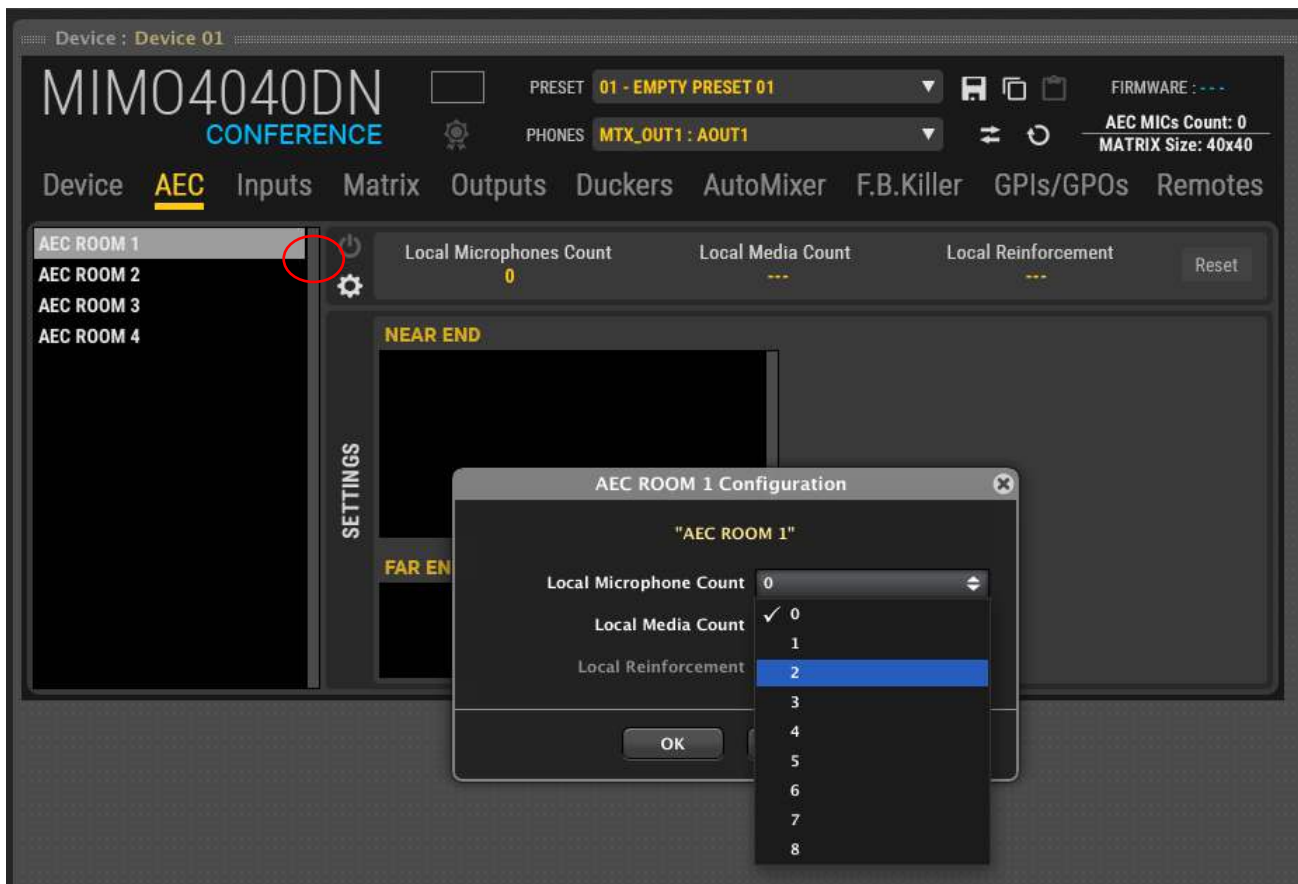

The AEC modules include a different and isolated processing and routing if compared with normal or “standard” input and output ports from the audio matrix. INPUT PORTS and OUTPUT PORTS selected in the AEC modules are not routed to the standard MATRIX (MATRIX section tab) in the MIMO unit. Matrix and AEC modules are independent, and can work autonomously and simultaneously with different input / output signals.

The following scheme resumes how the AEC room module is built:

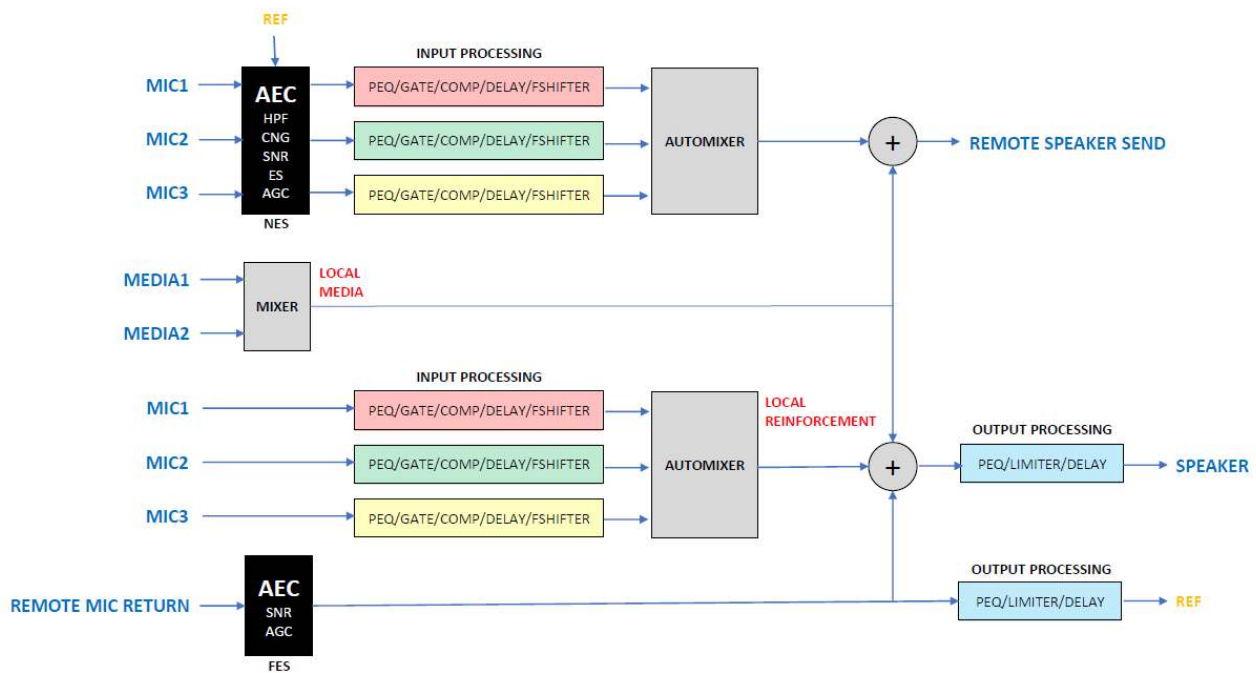

In each AEC ROOM CONFIGURATION window, it's also possible to select up to 2 LOCAL MEDIA: this allows sending non-microphonic local media contents (e.g. audio from a PC presentation or from an external AV player, but not audio from microphones in the room) to the REMOTE LOUDSPEAKER SEND (far-end) and to the LOCAL LOUDSPEAKER.

When LOCAL REINFORCEMENT option is selected, the signal coming from LOCAL MICROPHONES is also sent to the local loudspeaker without AEC processing. This option is suitable for big conference rooms where the signal coming from the microphones needs to be locally amplified and reproduced by the LOCAL LOUDSPEAKER.

The REMOTE MIC RETURN is the signal coming from the far-end and it represents the reference signal for the AEC algorithm after passing through the LOCAL LOUDSPEAKER processing, being listened in the room. This creates a more accurate reference signal for the echo cancellation algorithm.

As AEC is a very high-demanding DSP process, the more AEC channels are processed, the more standard audio channels from the standard matrix (MATRIX section) will be deleted to avoid a DSP processor overflow.

As long as you include local microphones in AEC Rooms, the following information will be updated:

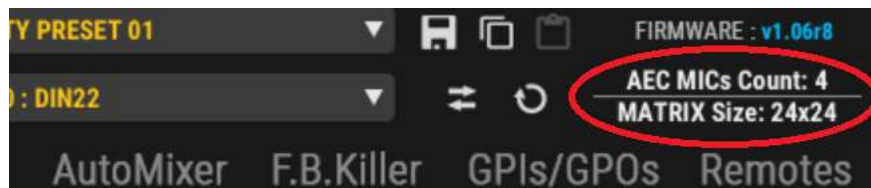

- AEC MICs Count: total number of local microphones included in AEC processing, among the 4 available rooms. Maximum = 8.
- MATRIX Size: size of the standard matrix, which is independent from the AEC processing, that will be still available.

Each microphone added to an AEC room will decrease the MATRIX size by 4 input channels and 4 output channels.

IMPORTANT NOTE: The AEC audio signals routing is managed by the AEC module itself, and it is independent by the standard matrix crosspoints routing. This means that **you don't have to (and must avoid!!) replicate crosspoints in the matrix for those inputs or output ports already managed by the AEC Rooms**. Take care of what input / output ports are assigned to Matrix Input / Output channels in the standard matrix, and don't route any of them exactly in the same way as AEC is doing. Otherwise, you will get two parallel and summed audio paths: AEC free of echo audio + echoed audio mixed together!

Important: A key factor to let an AEC algorithm work properly is that **the positioning and gain structures of the involved microphones and loudspeakers in the room are adjusted correctly**. AEC is not a substitute for a proper gain structure, or the proper placement of the microphones and loudspeakers: room acoustics, microphones and speaker placement, as well as gain structure are vital to get the best results in any AEC installation.

9.5.3.2. AEC Near-end Settings

In this chapter all the settings of AEC rooms are explained in detail.

Once the AEC room has been defined in terms of number of microphones, local audio media and local reinforcement, the AEC section will appear like follows:



Selecting each LOCAL MIC in the NEAR END SETTING window, it is possible to define the routing and the processing of the microphone signal processed by the AEC algorithm.

Through the INPUT PORT menu, you can choose the input port where the microphone will be connected. The input port can be one of the 8 MIMO4040CDN analogue inputs or one of the 32 Dante™ / AES67 channels. In order to make the project clearer, the port's custom label can be customized using the “N” button, like explained in the INPUT section of MIMO7272DN.



Once the routing is established, it is possible to process the signal with the following options:

- **HPF (High Pass Filter):** when active, this filter prevents the undesired low frequencies picked up by the microphone.
- **CNG (Comfort Noise Generator):** it adds low-level noise during silence moments in a conversation in order to realize that communication is still active and increase the user comfort.
- **SNR (Stationary Noise Reduction):** it reduces constant pattern background noise typically produced by fan elements, motors, air conditioners. Using the Noise Reduction control, it's possible to set the attenuation value from 0 to 30dB.
- **ES (Echo Suppression):** when active, it attenuates the echo once it is detected. The attenuation can be set from 0 to 60dB using the Echo Suppression control.

The two meters positioned in the AEC section are intended to give a qualitative indication of how the cancellation algorithm is working through two parameters called ERL and ERLE.

- **ERL (Echo Return Loss):** indicates the amount of loss that comes back as an echo and it is obtained from the ratio of the reference signal and the microphone signal. The ERL is a measure of how strong the echo is, and may be used as indicator to change position of the loudspeakers or microphones to reduce the echo in the microphones.
- **ERLE (Echo Return Loss Enhancement):** indicates the amount of loss introduced by the AEC adaptive filters and it is obtained from the ratio between the microphone signal and the residual difference of the signal after the AEC process. The ERLE indicates how well the Adaptive Echo Canceller is performing in reducing the echo.

They're as well available as indicators, to be included in UCP panels.

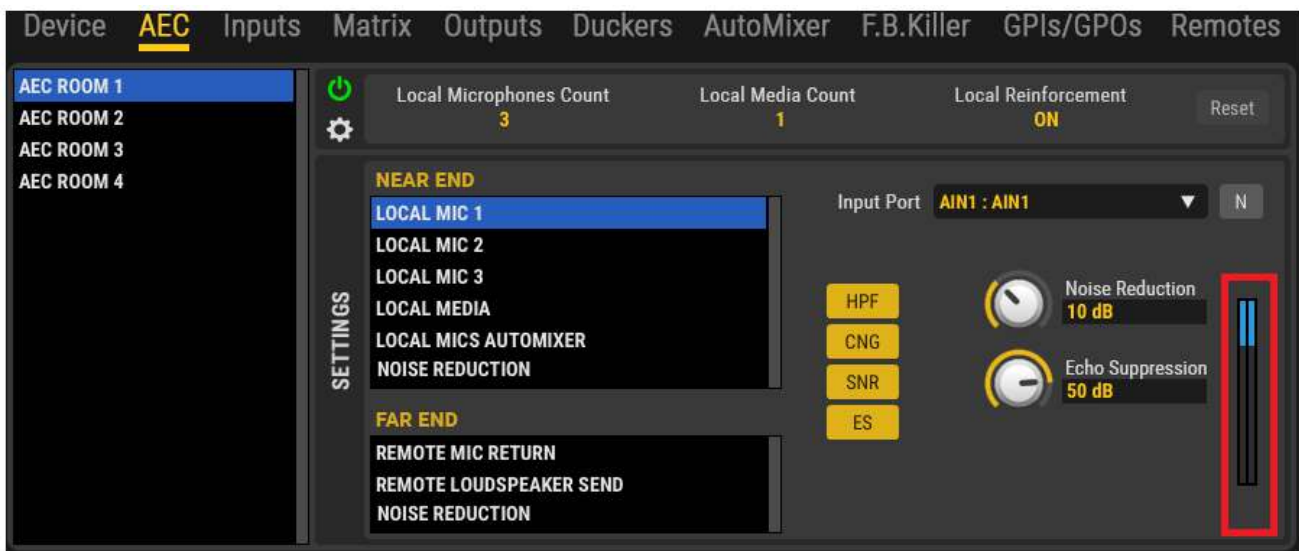

An optimal position of ERL is between the starting position and half scale. In case of full scale or negative values, it indicates issues on the gain structure.

ERLE can help in setting the ES (Echo Suppression) amount in order to keep the ERL value between the starting position and the half scale.

Each AEC room includes a **RESET** button just aside the room configuration resume:

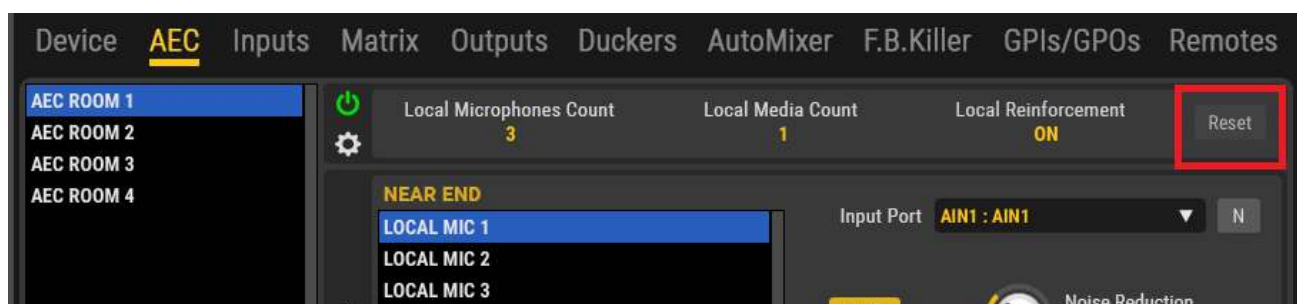

This button is used to restart the processing of AEC if changes are made in the configuration, gain structure, etc., or inside the conference room (for example if you move the microphones or if you change the position of the speakers). After pressing this button, the algorithm will automatically recalculate the parameters for the echo cancellation filters.

The reset button is available as well as a UCP control for the end users, allowing them to use it along a conference call if there's a circumstance that degrades the AEC efficiency at a given time, by any reason.

In addition to the AEC own processing, all the typical MIMO7272DN matrix settings for an input channel are available for the input signals and include (lower part of the screen):



- INPUT preamp settings: sensitivity, GAIN, MONO/ST management, Phantom power ON/OFF.
- Time Delay, up to 1 second (=343 meters)
- Parametric EQ, 4 filters
- Noise Gate
- Compressor
- Level, MUTE and Polarity inversion controls
- Frequency Shifter (feedback effect reducer)

In case that more than one microphone is selected, the AEC module will include an automixer. This automixer is dedicated to the room's microphones for the AEC processing, and is totally independent from the main MIMO4040CDN's AUTOMIXER section (AUTOMIXER tab): the only microphones involved are the ones defined in the AEC room.

The setting parameters are the same explained in the [MIMO4040CDN AUTOMIXER Section](#), and the behaviour is the same even if there are no light indications about the active microphones.

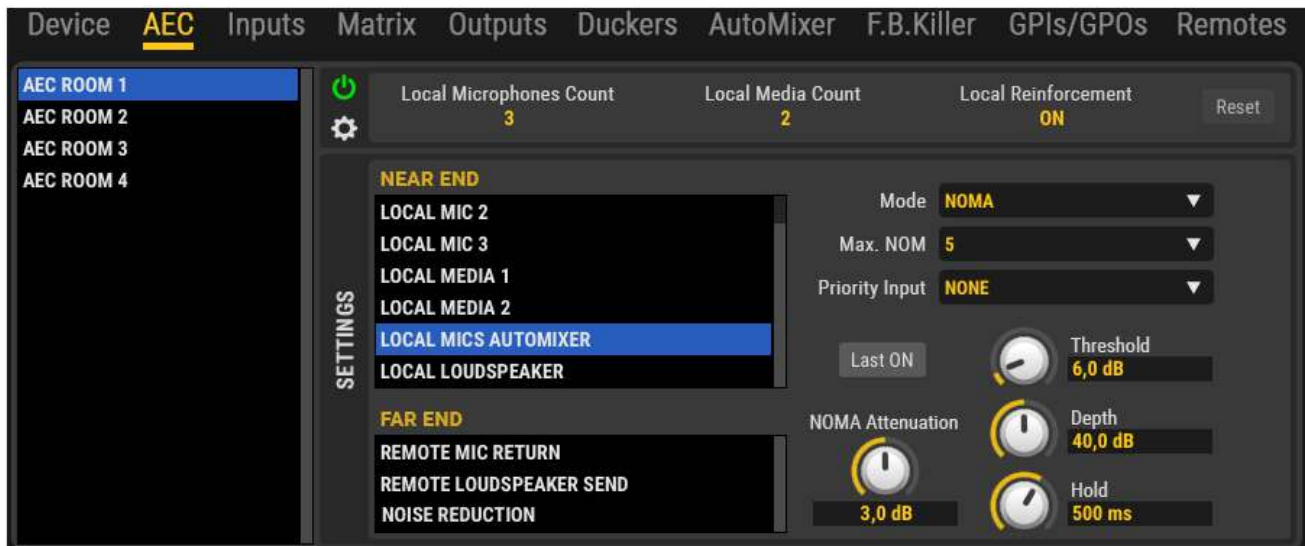

LOCAL MEDIA inside the NEAR END SETTINGS, allows adding up to 2 non-microphonic sources to the conference's AEC processing. Local media sources may be audio signals from local audio contents like, for example, audio from video presentations, recorded messages or any content different from microphone speech, that wants to be sent and heard by the Far end talkers, as well as by the near end ones.

When LOCAL MEDIA 1 and 2 are both used simultaneously, their audio signals are mixed together.

The Input Select menu, for LOCAL MEDIA 1 and 2, allows deciding where this audio media do will come from, and it just allows selecting **Matrix Output Channels**, instead of Matrix Input Channels or, directly, Audio Input Ports.

But why an **Output** Channel???

Because, in this way, whatever audio is selected to be sent to a given Matrix Output Channel (MATRIX section), using the standard matrix crosspoints, will then be used by the AEC module as its local media, in real time, even if more than one audio is selected, then mixed together:

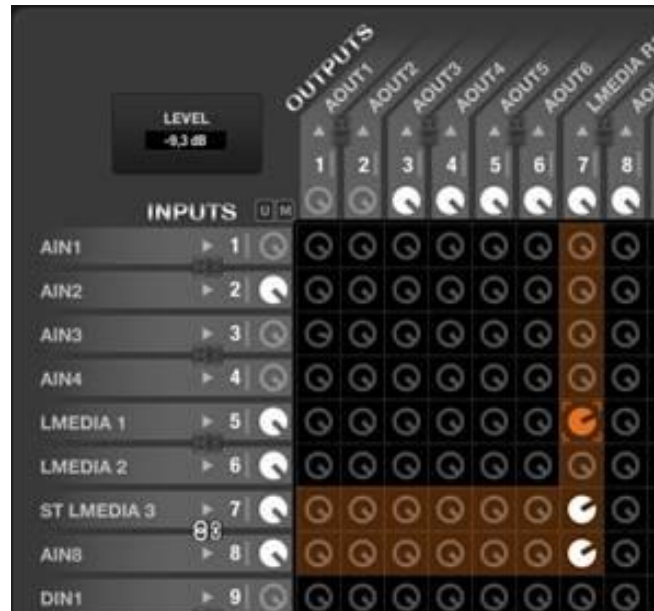

In the above example we can manage 3 media audio sources for our Local Media contents in Room 1. Note that the ST to mono conversion is as well managed automatically.

We will then select Matrix Output 7 as our Local Media source:

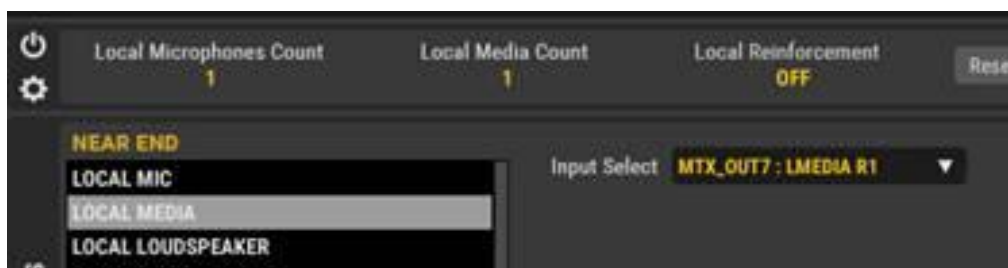

And, in the above example, there is no need to effectively route Matrix Output Channel 7 to any real audio Output Port, as that is done directly inside the AEC Room module processing: the local media will be routed to the Remote Loudspeaker Send and also to the Local Loudspeaker:



This method allows as well using carousels for source selection in UCP panels, or by means of digital wall panel controls. This way the end user can switch from one local media to another or mix more than one, in real time, meanwhile the conference call is active.

The LOCAL LOUDSPEAKER settings allow defining the OUTPUT PORT dedicated to receive and play in your room (near-end) the signal from the far end, the LOCAL MIDDLE signal (if any) and, optionally, the Near End audio signals, when the Local Reinforcement feature is ON. The output port can be one of the 8 MIMO4040CDN analogue outputs or one of the 32 Dante™ / AES67 digital outputs. As for the INPUT PORTS, the label can be customized using the “N” button.

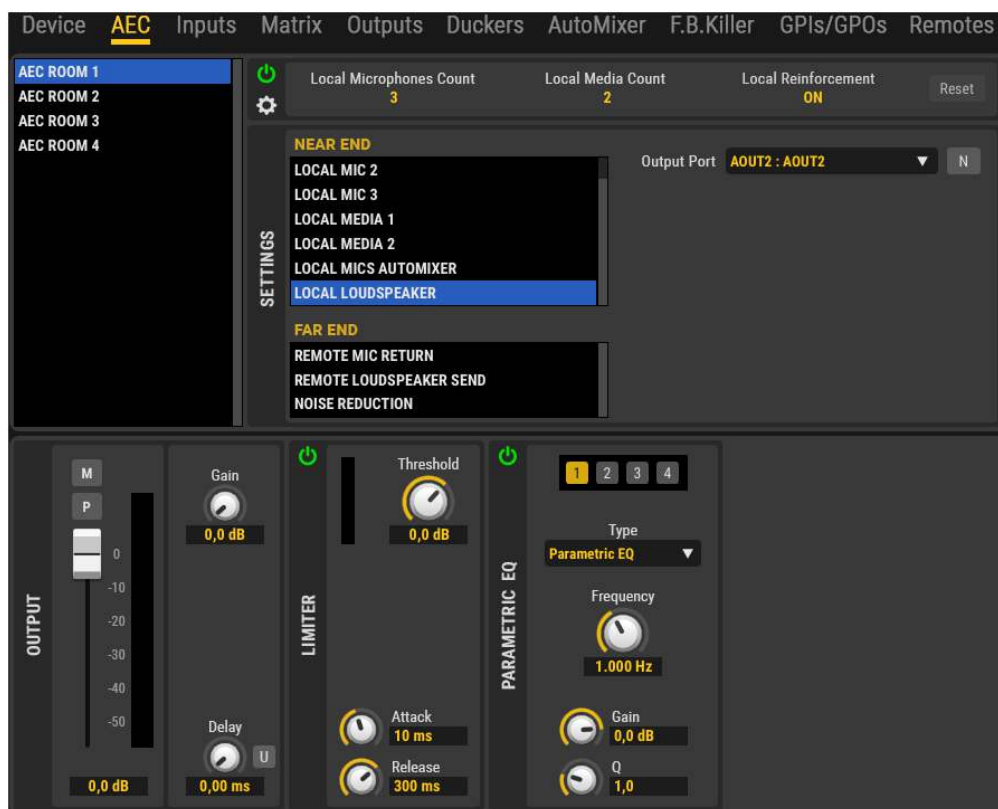

The processing available for the LOCAL LOUDSPEAKER signal includes:

- Level, MUTE and Polarity inversion controls
- Extra + 6dB GAIN
- Parametric EQ, 4 filters
- Time Delay, up to 1 second (=343 meters)
- Level limiter

9.5.3.3. AEC Far-end Settings

FAR END window always includes three setting options related to the incoming and out coming signals routing and processing options to improve the communication.

In details, the first option is related to the REMOTE MIC RETURN that represents the incoming audio signal from the far end, and it can be routed to one of the MIMO4040CDN inputs using the input port selector on the right side.

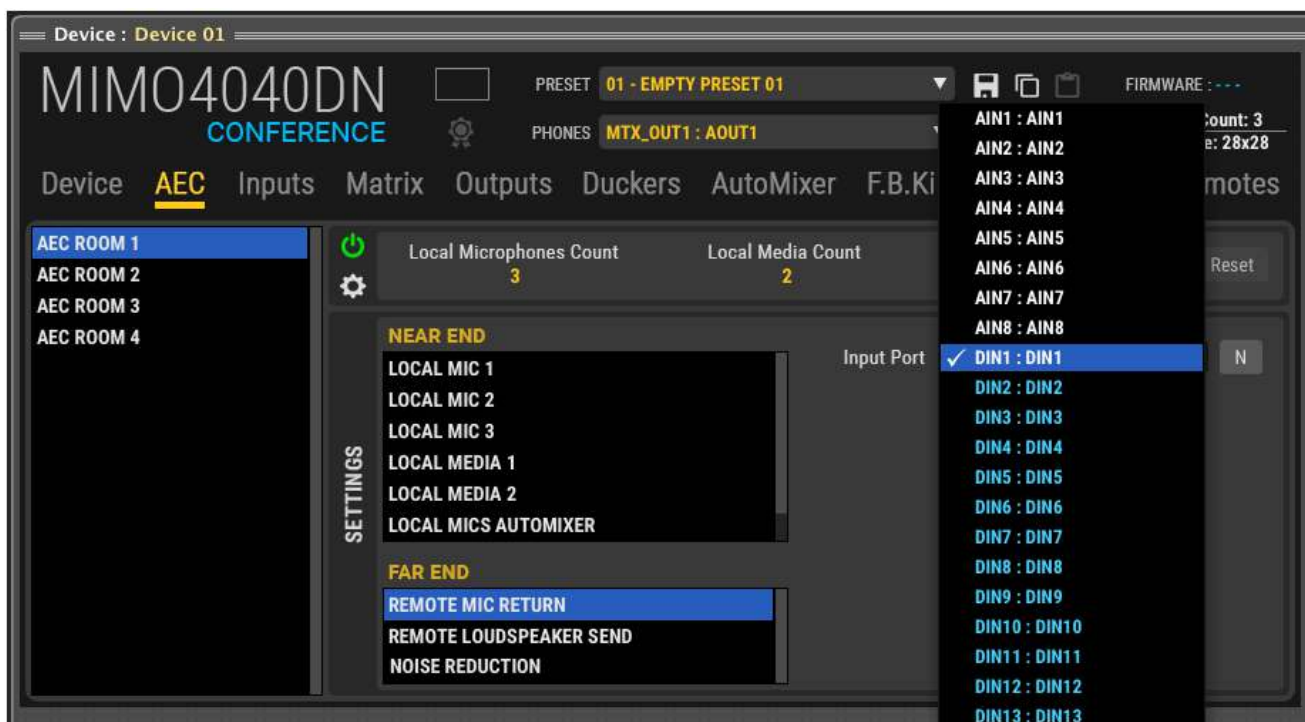

The input can be one of the 8 MIMO4040CDN analogue inputs or one of the 32 Dante™ / AES67 input channels. In order to make the project clearer, the label can be customized using the “N” button, like explained in the INPUT section of MIMO7272DN.

The REMOTE LOUDSPEAKER SEND represents the audio signal (microphones, local media) sent from the NEAR END to the FAR END after the AEC processing. Also in this case, it can be routed to one of the MIMO4040CDN audio outputs using the output port selector on the right.

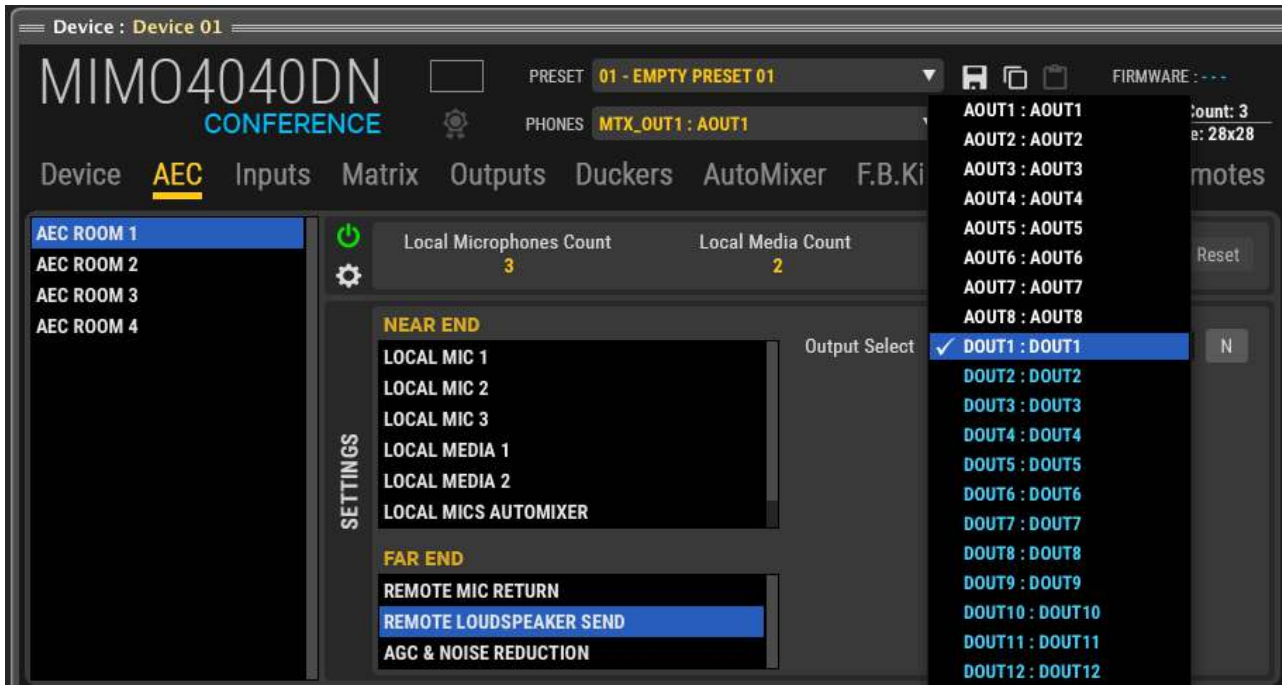

The output can be one of the 8 MIMO4040CDN analogue outputs or one of the 32 Dante™ / AES67 digital outputs. As for the INPUT PORTS, the label can be customized using the “N” button.

AGC & NOISE REDUCTION section allows adjusting about the processing of the incoming signal from the far end:

- **SNR (Stationary Noise Reduction):** it reduces constant pattern background noise typically produced by fan elements, motors, air conditioners. Using the Noise Reduction knob it's possible to set the attenuation value from 0 to 30dB.

9.5.4. DUCKERS Section

The aspect of the DUCKERS section of the MIMO4040CDN is as follows:

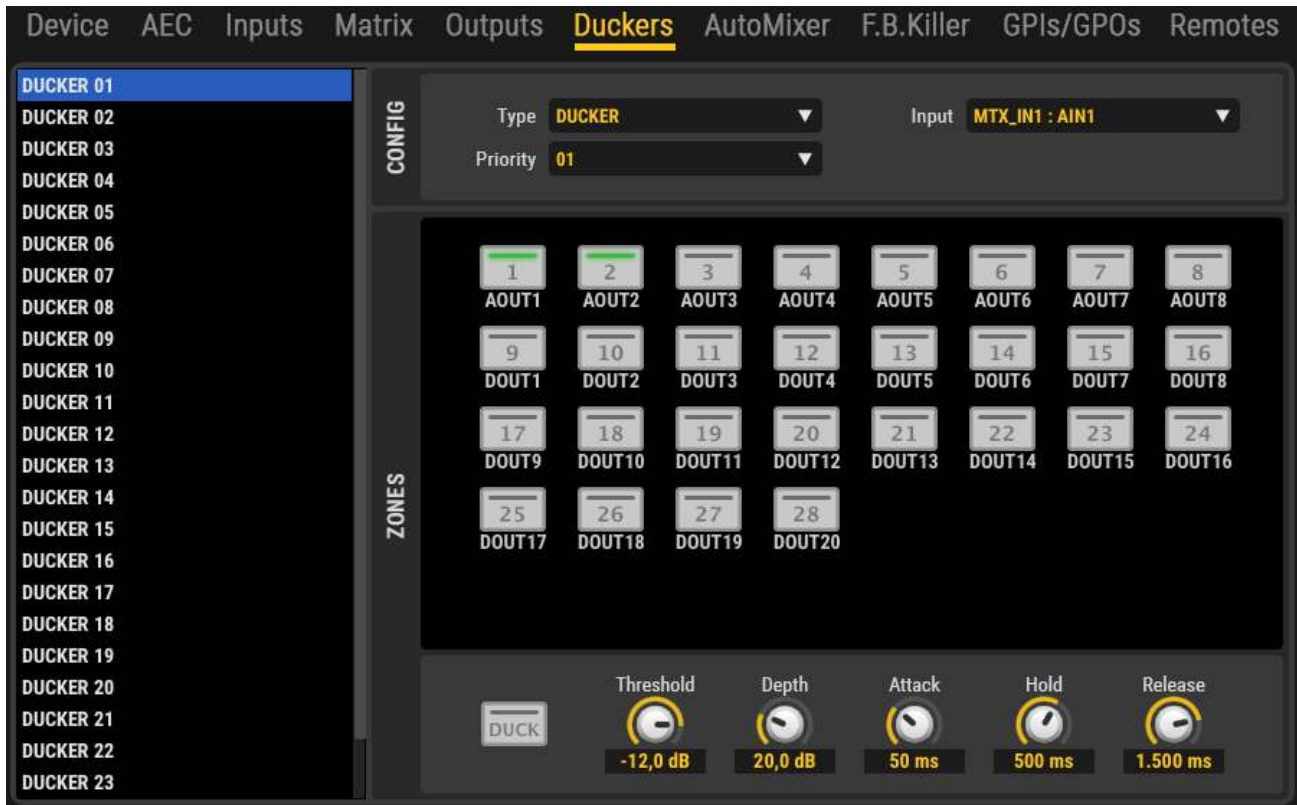

The differences compared to the standard version are:

- No PAGER modules (so this version is not compatible with the PAGENETDN paging station, when used for paging purposes)
- 25 DUCKER modules for handling signals with highest priority (emergency or evacuation messages, etc.). The modules can act directly on the outputs with full priority mixing functionality.
- From EclerNet v6 onward, the duckers of MIMO7272DN and MIMO4040CDN, can also be selected as triggers for digital events; please refer to [Simple digital events](#) section for further details.

9.5.5. AUTOMIXER Section

AUTOMIXER is a function available only in MIMO88, MIMO88SG, MIMO12SG and MIMO4040CDN versions, that allows to perform automatic mixing of incoming audio signals, while maintaining a control (also automatic) on the total gain of the mix and managing some parameters and priorities between these signals.

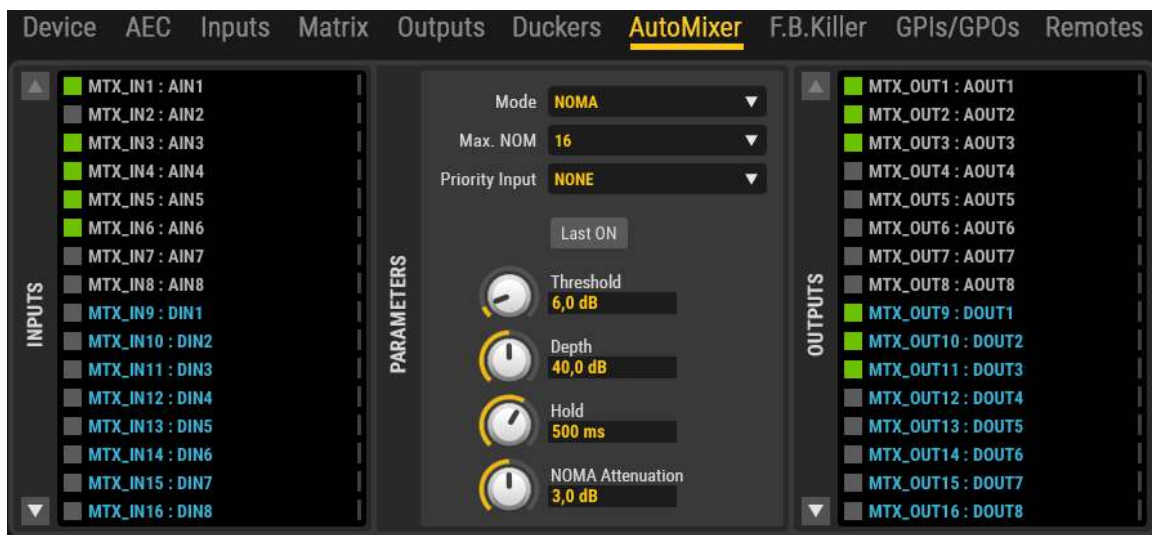

The AUTOMIXER processing module uses a very sophisticated algorithm to manage what input signals must be part of the automatic mix and under what conditions, and what signals must remain apart. The AUTOMIXER analyses the audio content on all inputs to identify what should be considered as background noise and what should be considered as a valid signal to trigger the input channel in the auto mix.

A clear and frequent example would be a conference application in a room with multiple microphones assigned to the automatic mixing process as sound sources. The signals simultaneously captured by all the microphones with a less high intensity could be considered as indirect, i.e. coming from a lecturer with the intention to be picked up by his own microphone, but inevitably also captured by the rest of the microphones in the room. In contrast, the signal picked up by the microphone of the speaker itself should logically be of much greater intensity.

The algorithm considers a large set of parameters related to the indirect signals to calculate in real time the background noise level of the mix and, from there, allows the signals exceeding some magnitude (set with the THRESHOLD setting) to enter and be part of the automatic mix. Inputs that do not meet the requirements to be considered as part of the automatic mix are attenuated by a number of decibels set with the DEPTH parameter (in certain applications it is preferable not to completely mute signals excluded from the automatic mix, but to attenuate them to a certain extent).

To the left of the screen you will find a list of all unit inputs, where you can select inputs you want to be a part of the automatic mix (left button in green for the selected inputs). The multicolour indicator to the right of each input shows its status at a given time:

- **Red:** the input level is below the threshold of the noise gate that allows the input of the signals in the automix (noise gate closed). Inputs 4 and 5 in this example.
- **Yellow:** the input level has exceeded the noise gate threshold (opened gate), but the input is not currently included in the automatic mix, according to criteria established for the automatic mixing algorithm. Input 3 in this example.
- **Green:** the input level has exceeded the noise gate threshold (opened gate) and the input is currently included in the automatic mix. Inputs 1 and 6 in this example.

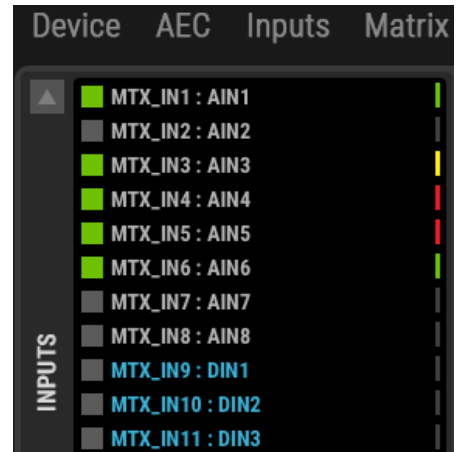

The small green level meters located to the right of the list indicate the activity of the signal present on each input.

To the right of the screen you will find another list, including all the device outputs, where you can select the outputs the automatic mix will be affected to. In this example, the automatic mix done in the AUTOMIXER module is routed to outputs 1, 2 and 3.

The small green level meters located to the left of the list indicate the activity of the signal present on each output.

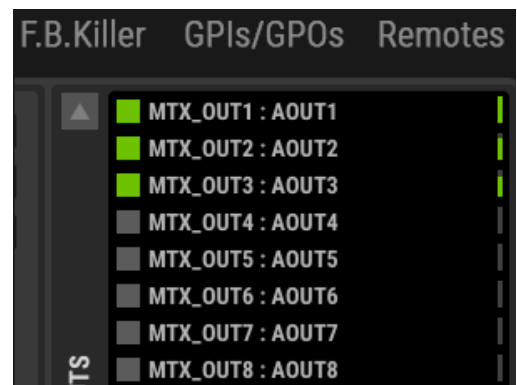

The inputs assigned to automatic mixing in the AUTOMIXER module **must first be properly assigned in the MATRIX section**, by adjusting the MUTE and level controls of its crossing points to correctly route them toward the desired outputs.

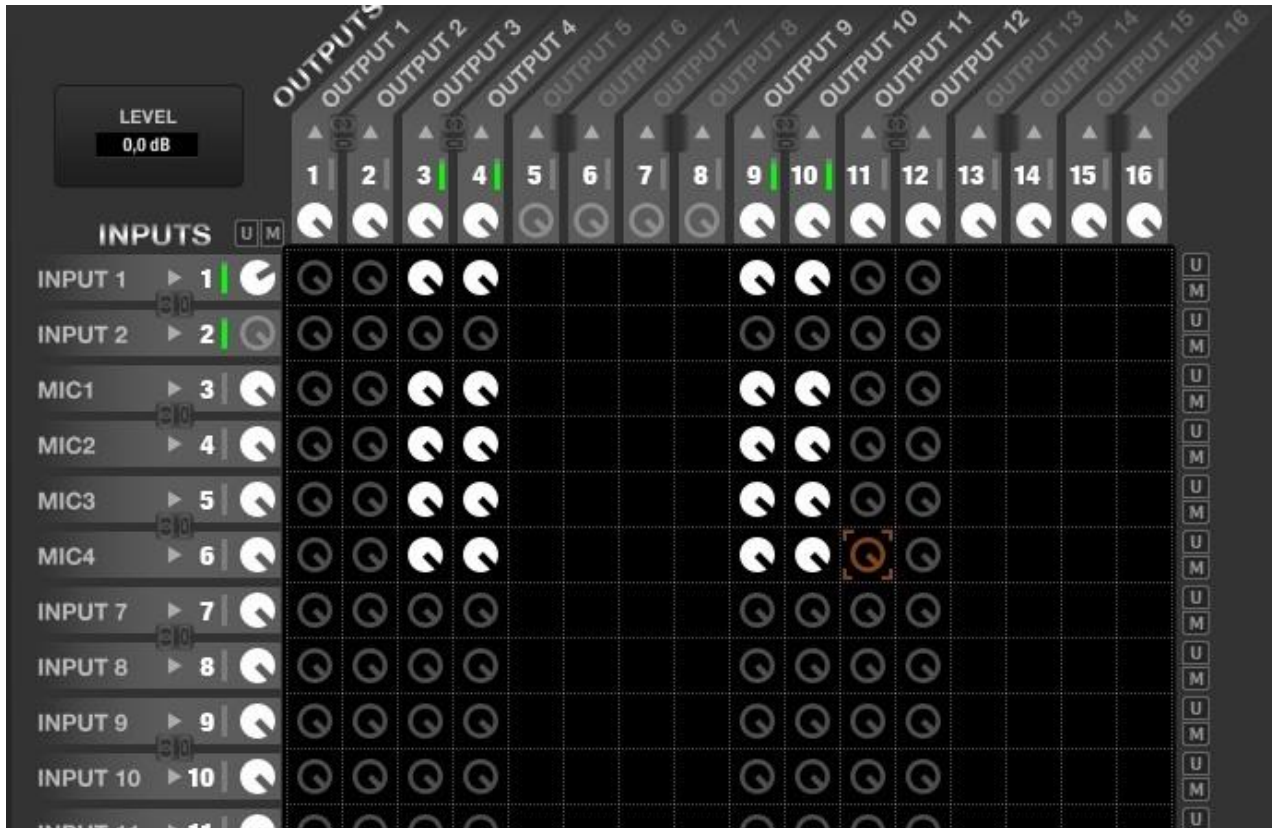

The picture above shows how inputs 1, 3, 4, 5 and 6 are routed toward outputs 3, 4, 9 and 10. Thus it would be possible that any selection of these inputs and outputs in the AUTOMIXER module could result in an automatic mixture according to the settings made in this module.

9.5.6.1. AUTOMIXER: NOMA or EXCLUSIVE automix modes

The AUTOMIXER has two operating modes:

- **NOMA:** “Number of Open Microphones Attenuated”. In this mode, the automatic mixing algorithm allows a fixed number of input signals (usually picked up by microphones) to be simultaneously part of the mix, reducing or increasing their total gain when the number of microphones included in the mix increases or decreases (more active signals in the mixture, less total gain).
- **EXCLUSIVE:** in this mode only, a single microphone is part of the mixer channel at a given moment, once the algorithm considers that it complies with its requirements. Another microphone can be used when the first one has released the channel.

The user controls of the AUTOMIXER section are the following:



- **MODE:** NOMA or EXCLUSIVE mode selection
- **MAX. NOM (NOMA mode only):** maximum number of signals that may simultaneously be part of the automatic mixing. Regardless of the number of inputs that have been selected in the INPUTS list (to the left of the AUTOMIXER window) as candidates to be automatically mixed, the MAX. NOM parameter sets how many of them can be mixed at a given moment with the automix algorithm. For example, if the application consists of 8 lecturer microphones, but MAX. NOM is set to a value of 4, only a maximum of 4 of these 8 microphones (from 0 to 4, in fact) are actually mixed automatically, although the 8 microphones capture signals above a certain intensity, the algorithm deciding at all times which of the 8 eligible inputs will join the mixing bus.
- **LAST ON:** when this option is enabled, at least the last signal to join the mixing bus will permanently remain in it, even when it no longer meets the input criteria, being composed only by weak signals or background noise. In this mode, the mixing bus will never remain fully silenced, thus avoiding the uncomfortable effect of audio "disconnection" of the system during the intervals in which there are no valid signals for the automatic mixing process.
- **PRIORITY INPUT:** if desired, define a device input that will have the highest "chairman" priority. When this input exceeds the noise gate threshold, it will become part of the mixing bus, inhibiting the other signals. The priority signal is the one that usually comes from the microphone of a moderator or chairman during conferences, debates, etc.
- **THRESHOLD:** input level of the signals in the automix bus, based on the internal threshold that the internal mixing algorithm automatically and dynamically calculates. The higher the setting, the greater the difficulty for the input signals to be incorporated into the mixing bus (a higher level will be required).

- **DEPTH:** attenuation level applied to the signals that are outside of the bus at a given moment
- **HOLD:** holding time of the signals within the mix bus, once they have entered into it, and after leaving to meet again with the criteria of admission
- **NOM ATTN.:** attenuation applied to the total gain of the automatic mix bus whenever the number of signals contained therein is doubled

9.5.7. FEEDBACK KILLER Section

FEEDBACK KILLER is a function available only in MIMO88, MIMO88SG, MIMO12SG and MIMO4040CDN / MIMO4040DN CONFERENCE versions. This section includes "notch" type filters with automatic adjustment, whose mission is to reduce the risk of audio feedbacks (or Larsen effect).

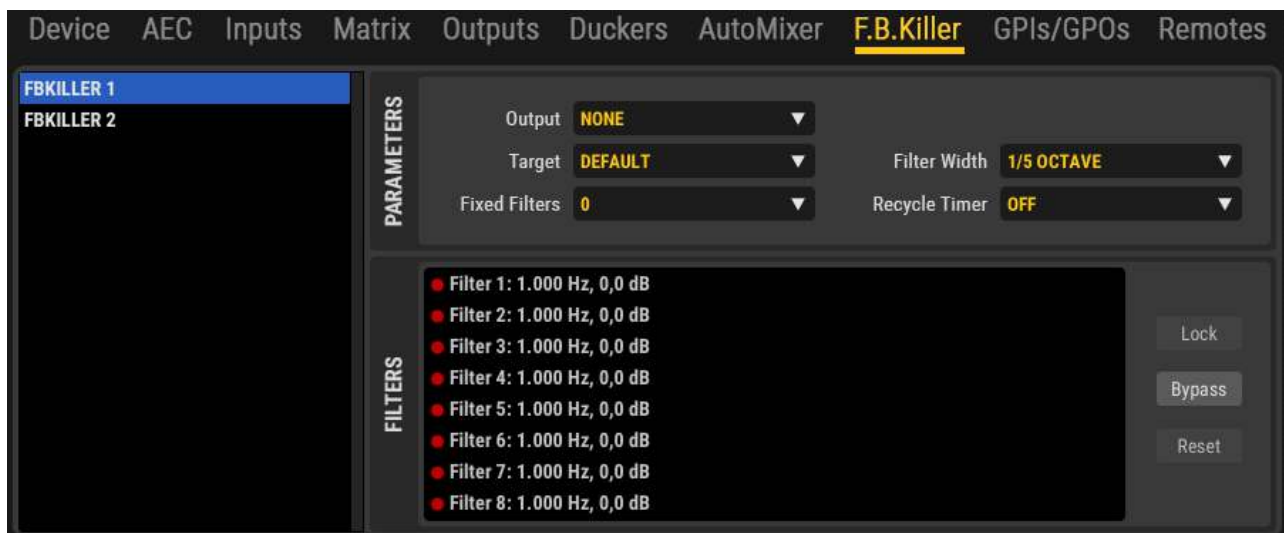

The FEEDBACK KILLER section consists of 2 banks, with 8 automatic filters in each one of them. The 2 banks are independent in terms of settings, operating mode and assigned output.

According to the settings, the FEEDBACK KILLER algorithm continuously analyses the input-output loop assigned to each bank, detecting in real-time frequencies prone to feedback then automatically assigning notch filters to these frequencies. Each notch filter is set (centre frequency and attenuation) to reduce the level of a band of frequencies in order to avoid a feedback effect.

The image shows the bank 1 with 6 of its 8 filters assigned to frequencies that the algorithm has detected as prone to feedback:

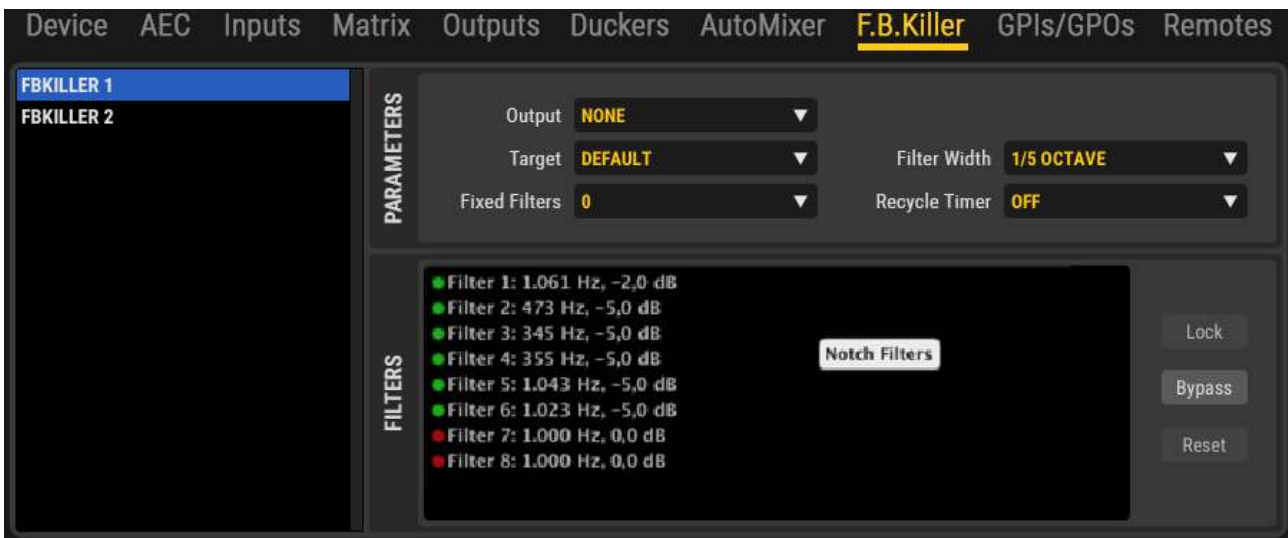

To the left of the window is the selection list for one of the two banks (FBKILLER 1 and FBKILLER 2). Clicking on one of them allows you to adjust their settings:

- **OUTPUT:** the system output the filter bank is applied to in order to cancel or minimize its potential feedbacks
- **TARGET:** allows you to select among 4 preset application profiles, each one of them with the algorithm optimized for the application. Each of these profiles adjusts algorithm internal parameters such as the feedback detection sensitivity and the maximum attenuation applied by the filters. It is important to correctly set this parameter considering the application characteristics (music or speech) and the room type where to work (large or small), given that its own reflections and modes differently affect the risk of feedback in all the cases considered as profiles for the TARGET parameter. A conference application using a MUSIC profile will surely give worst results than if you employ a SPEECH profile, and vice versa.

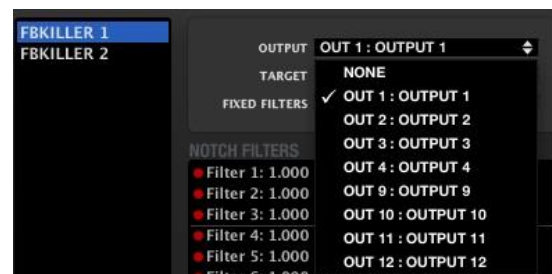

- **FIXED FILTERS (from 0 to 8, per bank):** determines the number of filters that, once set, remain fixed over time (static) until you change the MIMO88CONF setting that affects them (recalling a preset with other settings, loading a new project, rebooting the computer, etc.).



A horizontal line visually separates fixed filters (the first three in this picture) from dynamic filters (the following five in this picture). Dynamic filters can be reset over time if the algorithm detects that it is necessary (microphones moved in the room, changes in the acoustic conditions, etc.).

- **FILTER WIDTH (1/5 or 1/10 Octave):** determines the bandwidth of each one of the notch filters of the bank, or the frequency range that will be affected (attenuated) by each filter, using its centre frequency, automatically detected, as the centre of this range

- **RECYCLE TIMER:** determines the minimum necessary time between the setting of each dynamic filter and its releasing for a new setting on another frequency of potential feedback, when the algorithm detected this need

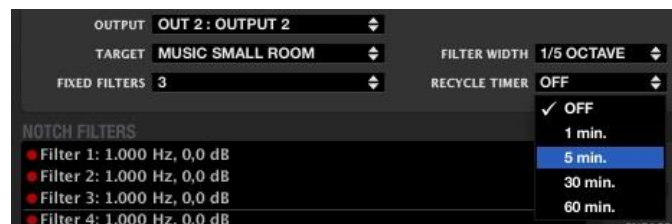

- **LOCK:** locks the status of already set filters, not allowing more static filters setting (if any) nor dynamic filters setting or resetting
- **BYPASS:** when activated, temporarily disables the FEEDBACK KILLER function, while keeping the adjustments and filters set in memory. When deactivated, re-enables the function, recovering the previous settings
- **RESET:** totally resets the 2 banks of filters, now available again for setting.

10. EclerNet COMPATIBLE DEVICES: Audio Players

10.1. DUO-NET PLAYER

10.1.1. Introduction to DUO-NET PLAYER, Dual Streaming Receiver & Media Audio Player

ECLER DUO-NET PLAYER is a double stereo audio sound source that features full EclerNet compatibility (EclerNet Manager software, UCP control system, WPmSCREEN / WPNETTOUCH remote management, TP-NET third party integration protocol, etc.). It includes 2 independent stereo media players, each one being able to play Internet audio streams and local (SD, USB) or networked audio media.

DUO-NET PLAYER can be used as a stand-alone media player or integrated as a piece of a full EclerNet system, as well as coexisting with third-party devices.

These are DUO-NET PLAYER main features:

- 2 independent media players, PLAYER A and PLAYER B, each one linked to a dedicated stereo output (Euroblock connectors, balanced signal)
- Compatible with mp3, ogg, AAC, WAV and FLAC audio formats
- SD and USB slots for local storage media contents (up to 32GB, FAT16/32 format supported)
- Ethernet interface (RJ45 connector) for EclerNet and TP-NET control, Internet streaming reception and networked (LAN) media playback
- Fully programmable and controllable via EclerNet Windows© software
- UCP (User Control Panels) remote control system, compatible with WPmSCREEN / WPNETTOUCH and third-party client devices (iOS©, Windows© and Android©)
- Integrated RTC (Real-Time Clock) and NTP (Network Time Protocol) synchronization, for scheduled events triggering
- 4 GPI ports (General Purpose Inputs) to trigger events by means of external dry contacts closure
- IR remote control for basic end-user control
- Priority media playback (emergency, advertising, etc.) over program audio



10.1.2. DUO-NET PLAYER detailed view, general section of the device

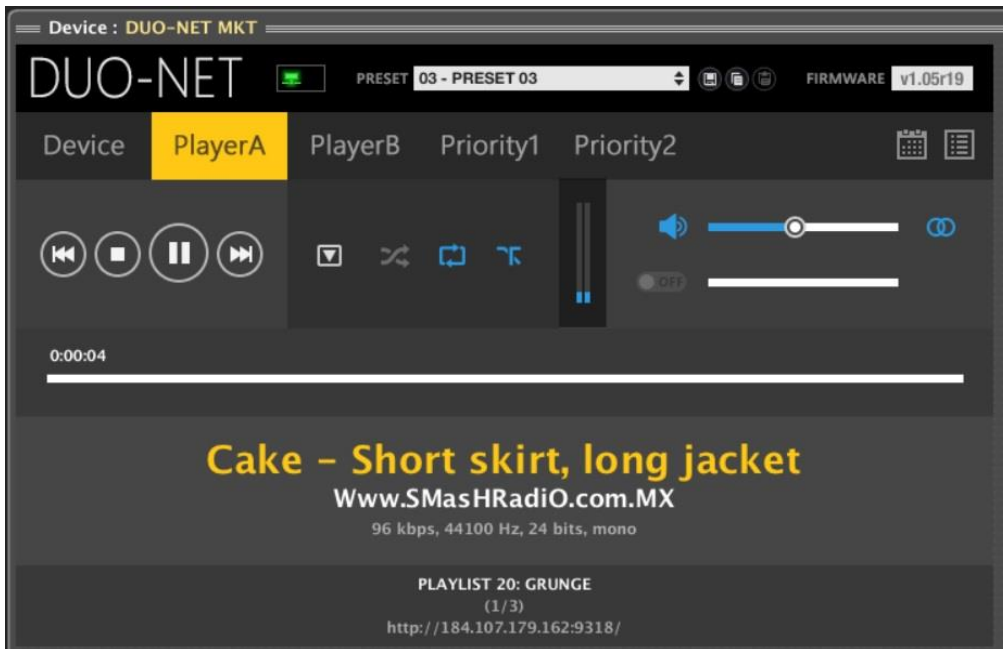

This is an example of how a DUO-NET player looks like when seen by EclerNet Manager:



As it happens with the rest of EclerNet devices, the top side of the detailed view shows some general parameters and options of the device:

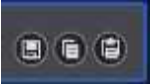

	<p>Status monitoring and alarms window.</p> <p>See Table of status monitoring and alarm icons</p>
	<p>Active Preset window: indicates the Preset currently active in the device</p>

 <p>See (1)</p>	<p>Presets management icons:</p> <p>Save Device Preset: saves the current Preset in memory (click on the mouse left button) or in a folder on your PC (click on the mouse right button)</p> <p>Copy Device Preset: copies the current Preset</p> <p>Paste Device Preset: pastes the previously copied Preset, within the same unit or to a different DUO-NET unit</p>
	<p>Unit's firmware version</p>

(1) Save Device Preset (saves the current Preset).

Left-clicking this icon opens a window with the following options:



- Name of the Preset to be saved at the selected position (preset number can't be changed)
- Data saved in the Preset: PLAYER A settings, PLAYER B settings, PRIORITY modules settings and EVENTS enable/disable status (for the 20 presets in the unit)

Presets are configuration memories of the device, including several working parameters' values. A Preset stores just the data selected in the previous window, so that recalling the Preset in the future will just change (overwrite) the data stored in this particular Preset, not affecting other parameters of the DUO-NET.

This ability to save "partial" Presets offers a great freedom of management.

Example: one Preset including just the configuration of PLAYER A and a second one including just the configuration of PLAYER B. By loading either of these two Presets during system operation, only PLAYER A or B will be affected, allowing the other player to keep on working without interruption or changes.

Right-clicking this icon opens a window with the following options:

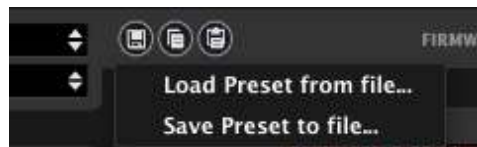

- *Load Preset from file*: lets you load a Preset stored in a hard drive, external USB memory, etc.
- *Save Preset to file*: lets you save a Preset in a hard drive, external USB memory, etc.

These two functions are very useful for copying in a DUO-NET unit a Preset coming from another unit currently offline, or from another Project or facility. Preset files are saved on disk with a ".DUONET_preset" suffix.

Under the top section, we find these tabs. Clicking on each of them will show a dedicated window for the configuration of the device general parameters, the players A and B, the Priority 1 and 2 modules, the Events and the Playlists:



10.1.3. DUO-NET DEVICE section

This section includes the following parameters:

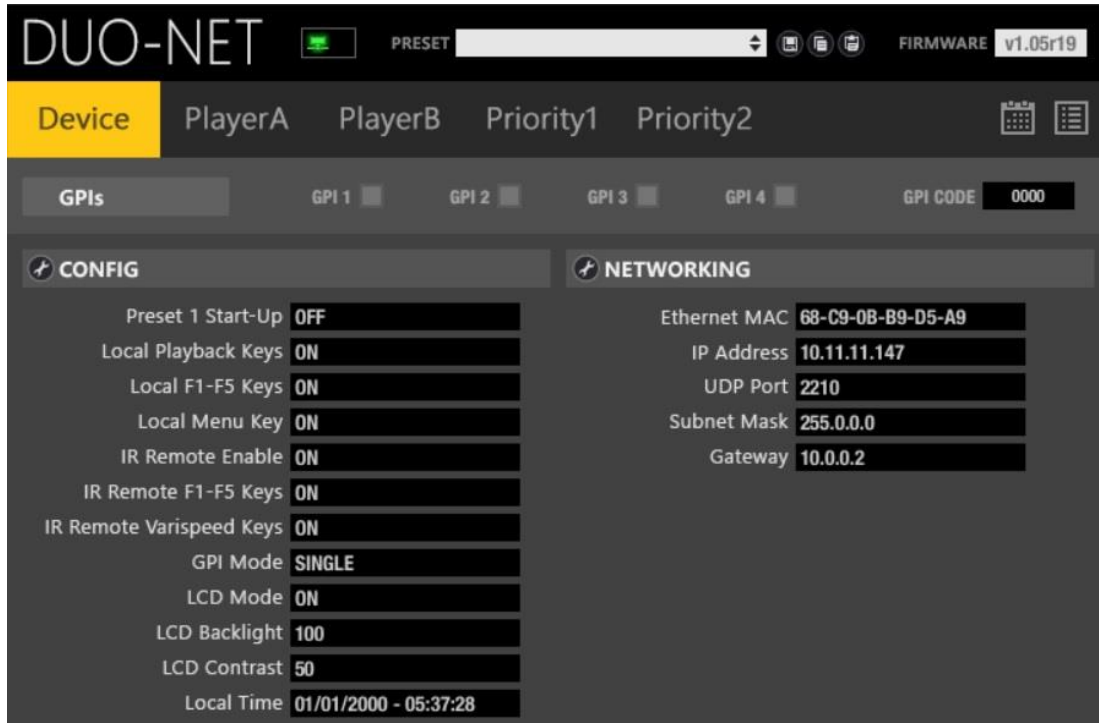

The GPI LEDs show the activity of the active / inactive GPI contacts at the back side of the unit. In the following image GPI #1 and #3 are ON (ON = connected to the "+" terminal by means of an external contact closure, or to an external voltage source, +10VDC).



GPIs can trigger events, working in Direct or in Binary mode. In the above example the equivalent binary code of the active GPIs is 0101, where GPI1 is the LSB (Least Significant Bit). See DUO-NET EVENTS section for further details.

Clicking on the CONFIG icon will open the following window:

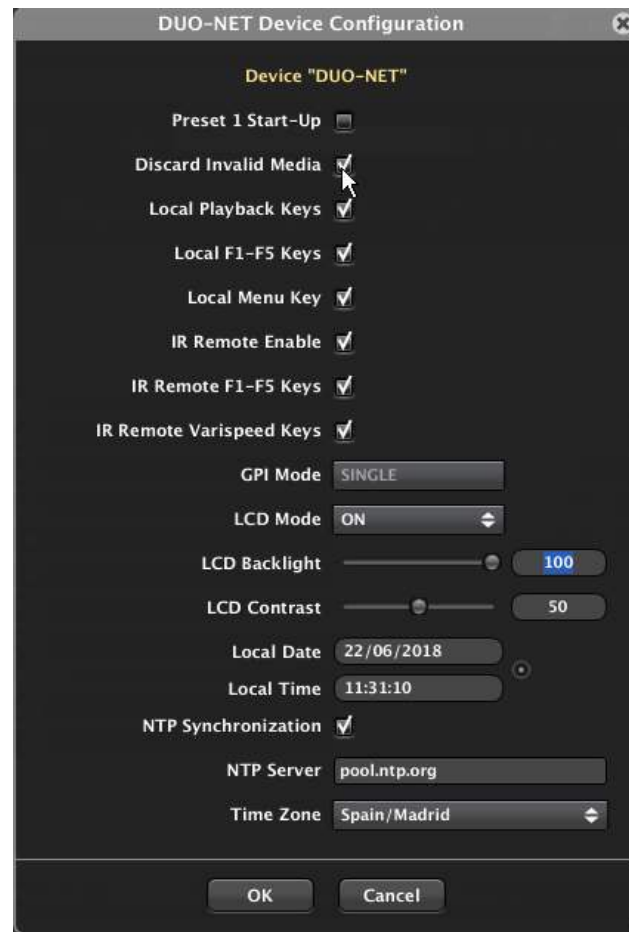

- **Preset 1 Start-Up:** when this box is checked, the DUO-NET unit loads Preset #1 whenever initialized, that is, every time you turn it off then on again. Otherwise, the DUO-NET will start with the last configuration, remembering controls and parameters values before shutdown
- **Discard Invalid Media:** in case a media reports errors when trying to play it, it is possible to decide whether it will be discarded for future play attempts (function = ON) or not (function = OFF). For the media which is not discarded, and included in a playlist in loop mode, DUO-NET PLAYER will try again to play it in future reading attempts. It is a very helpful function to avoid discarding, for instance, Internet streams that once failed for any reason, but don't want to be discarded for future reading attempts (**new feature, from ENM v4.05r1**)
- **Local Playback Keys:** enables / disables the four front panel transport keys function in the DUO-NET unit (PLAY/PAUSE, STOP, PREV and NEXT)
- **Local F1-F5 Keys:** enables / disables the front panel programmable keys function (see EVENTS section for further details about the functions that can be assigned to these keys)
- **Local Menu Key:** enables / disables the front panel MENU key function (protection against unwanted configuration changes, like the IP address, etc.)
- **IR Remote Enable:** infrared remote control full enable / disable option

- **IR Remote F1-F5 Keys:** enables / disables the infrared remote control F1-F5 keys function (see EVENTS section for further details about the functions that can be assigned to these keys). The remote control includes a total of 10 keys of this kind: F1-F5 for PLAYER A and F1-F5 for PLAYER B
- **IR Remote Varispeed Keys:** Enables / disables the infrared remote control Varispeed keys function (track's tempo modification)
- **GPI Mode:** GPI ports working mode
 - **SINGLE:** each GPI will trigger an individual event, offering a maximum of 4 different events in total
 - **BINARY:** each GPI is a bit in a 4 bit binary code, being GPI1 the LSB (Least Significant Bit), offering a maximum of 15 different events in total (from code 0001 to code 1111)
- **LCD Mode:** backlight intensity in idle mode (after several seconds with no local controls activity):
 - **ON:** always ON
 - **OFF:** backlight totally OFF
 - **DIMMED:** backlight attenuated
- **LCD Backlight:** LCD backlight intensity, in a scale from 10 to 100
- **LCD Contrast:** LCD contrast, in a scale from 0 to 100
- **Local Date and Time:** internal clock settings, with a button (round dotted icon) to synchronize it with Windows clock.
- **NTP Synchronization:** DUO-NET can automatically synchronize its clock with an NTP service (Network Time Protocol). To allow this happens, a valid NTP server must be entered in the NTP Server field (example: pool.ntp.org) and the desired Time Zone must be as well selected, according the location where the DUO-NET is going to be used

Clicking on the NETWORKING icon will open the following window:

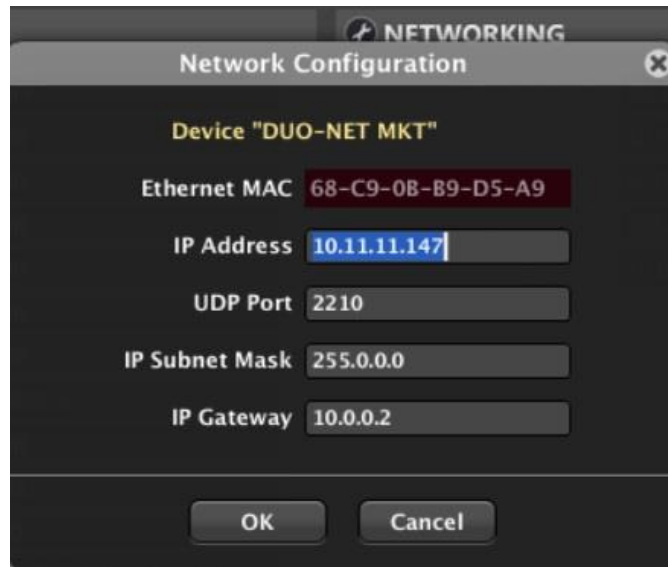

As every EclerNet device and computer belonging to an EclerNet project, the DUO-NET needs to get a **manually configured static IP address and subnet mask**.

Additionally, as DUO-NET is a device that can receive and play audio streams directly from the Internet, **the IP Gateway is a fundamental parameter to set up**, according to the Internet Gateway (usually the Internet router) existing in the installation's LAN. Otherwise, no access to Internet online radios and streams will be available for playback in Player A and/or Player B.

10.1.4. DUO-NET PLAYER A and PLAYER B sections

These sections are identical regarding their controls and parameters, but totally independent, one linked to the PLAYER A stereo output and the other one to the PLAYER B stereo output:

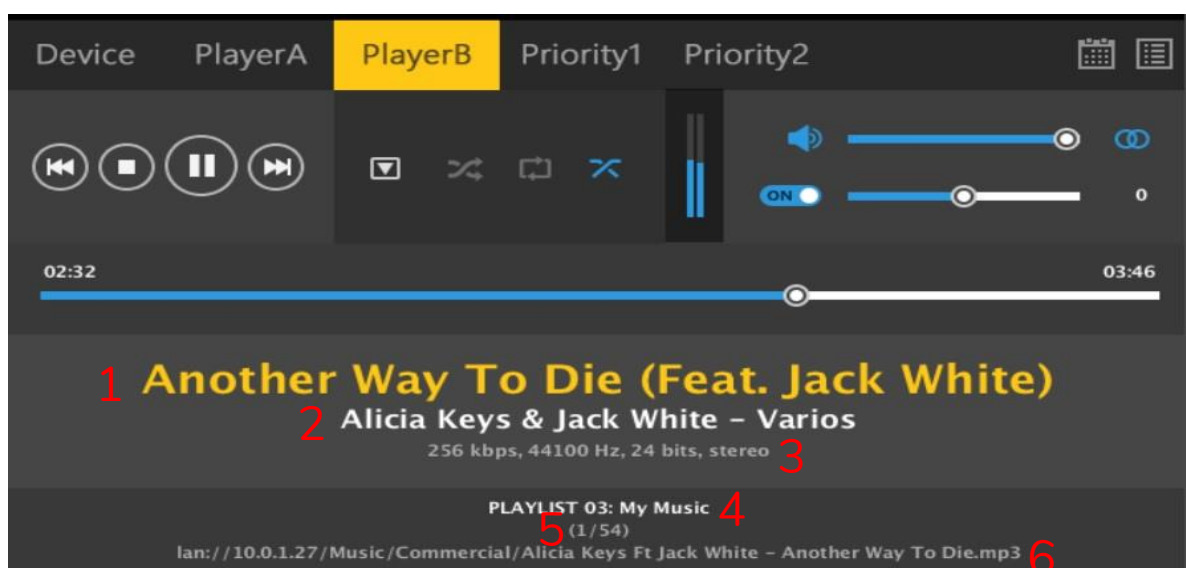

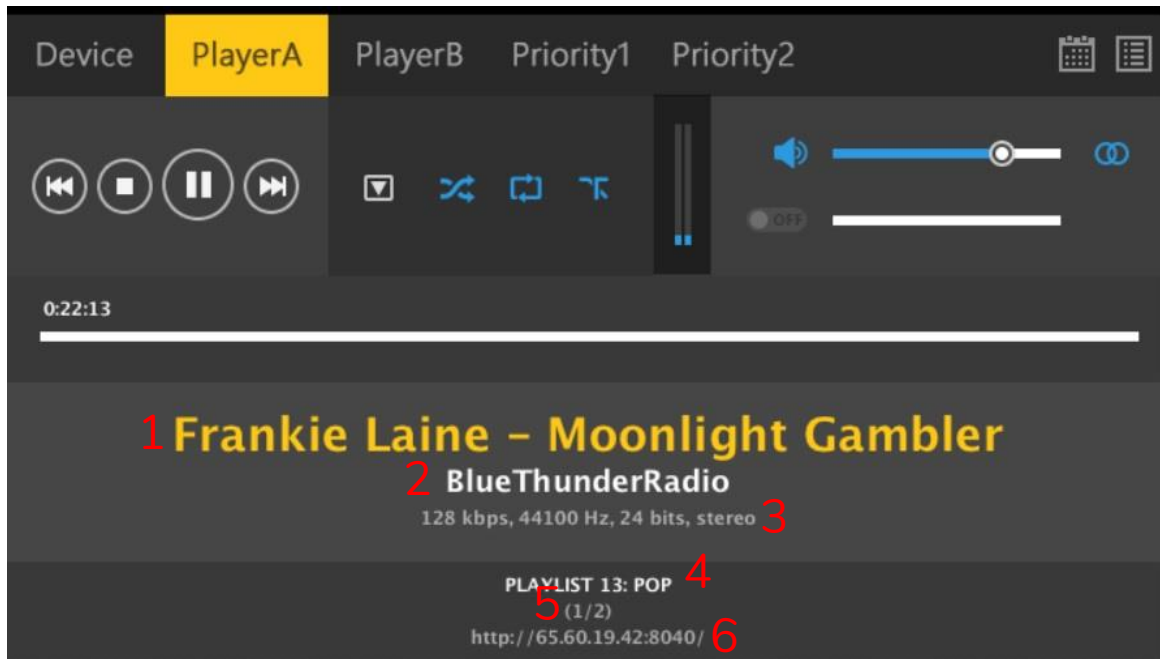

The text information on the bottom side of the window shows:

1. Track information tags
2. Internet streaming station information tag (station name) or artist / album tags information
3. Track encoding information: bit rate, sampling frequency and bits, stereo / mono format
4. Playlist bank position in use, from the 99 available (see PLAYLISTS BANK section for further details)
5. Item currently played back / number of valid items in the play queue (n/m): each time a playlist is loaded in Player A or B, the DUO-NET checks the compatible and valid items (individual tracks or media, internet streams, etc) and adds them to the play queue, discarding the non-valid ones (not compatible, not found, etc.). n shows the item currently in playback and m shows the total number of items in the play queue.
6. In case the playlist content under current playback has an ALIAS name, it is as well shown to the right of the (n/m) information.
7. Path / url of the audio media currently playing back

A time bar shows the current media playback time, in the case of Internet streams looking like this one:



And like this one in the case of local media (USB / SD) or media stored in LAN folders, including elapsed and total media times (it's as well possible to set a direct position assignment by clicking or scrolling the playback bar (**new feature, from ENM v4.05r1**):



The top side of the window includes these controls:

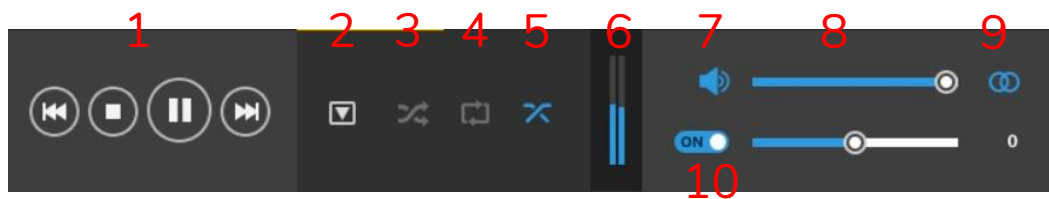



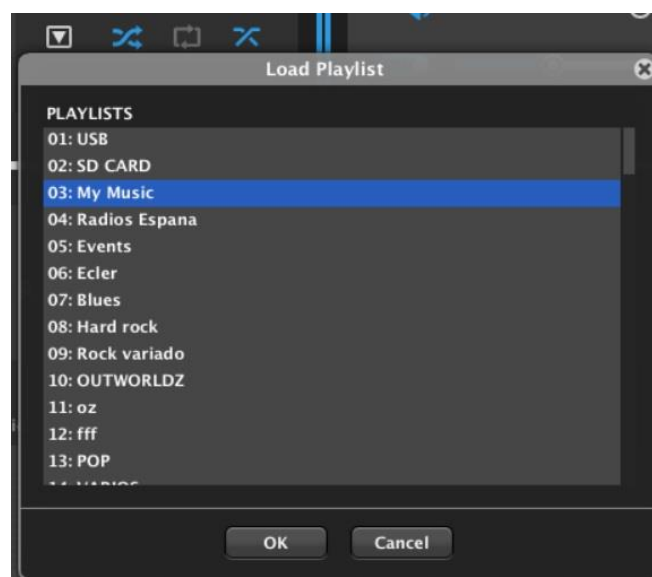

1. Transport keys:

- **PREV / REW:** Previous track or item in the play queue and Rewind controls (when pushed and held, **new feature, from ENM v4.05r1**)
- **STOP**
- **PLAY / PAUSE:** PLAY or PAUSE toggled functions in the same key
- **NEXT / FF:** Next track or item in the play queue and Fast Forward control (when pushed and held, **new feature, from ENM v4.05r1**)

- 2. **Load Playlist:** allows to load a given playlist in PLAYER A or B, from the 99 available in the bank



After loading one of them in PLAYER A or B, the DUO-NET will check its contents and include in the play queue just the available (found) and valid (compatible) media. See PLAYLISTS BANK section for further details.

3. **Play Mode:** SEQUENTIAL (greyed) or RANDOM (blue symbol)
4. **Repeat Mode:**
 - **PLAY ALL:** plays back all the items in the play queue, just once (no repetition)
 - **PLAY ONE:** plays back the selected item (current media), just once (no repetition)
 - **REPEAT ALL:** repeats the full play queue in loop mode (endless)
 - **REPEAT ONE:** repeats the selected item (current media) in loop mode (endless)
5. **Fade mode:** playback transition mode between two consecutive media in the play queue
 -  **NO FADE:** right after a media under playback finishes, the next one in the play queue starts its playback, none of them with fading in or out
 -  **CROSSFADE:** the track finishing fades out meanwhile the next one fades in, both being mixed during this fade short interval
 -  **FADE:** the track finishing fades out, and after its end, the next one fades in, without being mixed
 -  **HALF-FADE:** the track finishing fades out, and before its end, the next one starts to be played back at full level (no fade in), begin mixed during this interval
6. **Volume meters:** bar type audio volume meters for the Left and Right outputs of the player
7. **MUTE ON/OFF:** loudspeaker symbol in blue colour means MUTE is OFF (audio not muted)
8. **VOLUME:** audio volume control for PLAYERS A / B, independent of the priority modules' own volume (**new feature, from ENM v4.05r1**)
9. **MONO / STEREO mode:** sets the audio output of the player in stereo (two circles symbol) or mono (one circle symbol) modes. In mono mode, both left and right outputs deliver the same L+R mono signal, doing a stereo to mono conversion in case the original media was a stereo one
10. **VARISPEED ENABLE / DISABLE and VARISPEED control:** these controls allow to speed up or down the track's tempo (bpm), a useful feature in fitness and similar applications. The bpm increment / decrement is shown in percentage (in the next picture it shows a +12% value)



10.1.5. DUO-NET PRIORITY 1 and PRIORITY 2 modules sections

These sections are identical regarding their controls and parameters, but totally independent in terms of functionality.

A Priority module is a function able to playback an audio media with priority on top of the **program audio** (playlist, tracks or streaming media) being played in one or both players (A, B) of the DUO-NET. When played, the priority media can attenuate (override) or even totally mute the program audio in the destination player(s). The program audio gets back to its previous status after the effect of the priority is over.

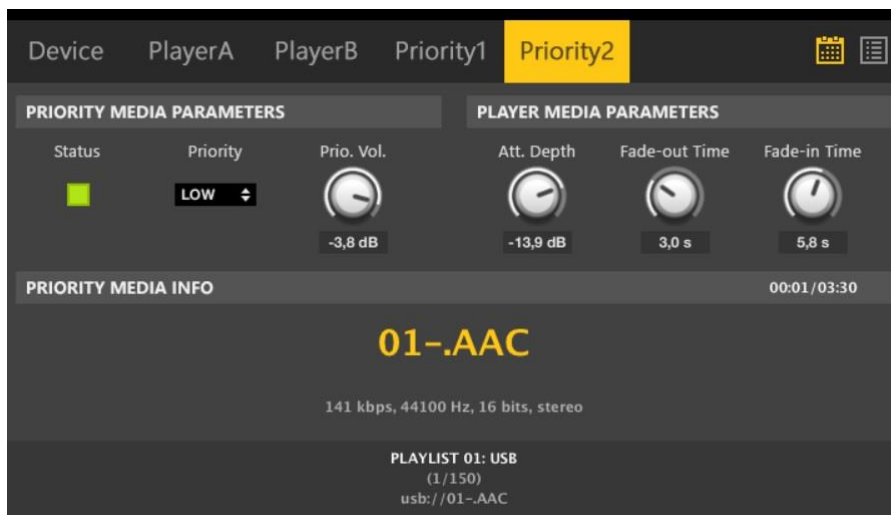

Priority modules are a tool to playback pre-recorded audio messages (evacuation messages, event announcements, marketing ads, commercials, etc.) triggered by a given schedule (using scheduled events) or triggered by different other stimulus, like external dry contacts, switches, buttons or detectors (connected to GPI ports), front panel F1-F5 keys, IR remote F1-F5 keys or virtual buttons available in UCPs (User Control Panels).

Both modules can be configured independently and their configuration can be stored in DUO-NET presets, so that recalling different presets can recall different Priority modules configurations. See PRESETS section for further information.



Priority modules are always triggered by EVENTS, which define how are they triggered, which is the priority media to be played and which is the destination of the priority media (PLAYER A, B or both). See EVENTS section for further information.

These are the parameters that define the configuration of a Priority module:

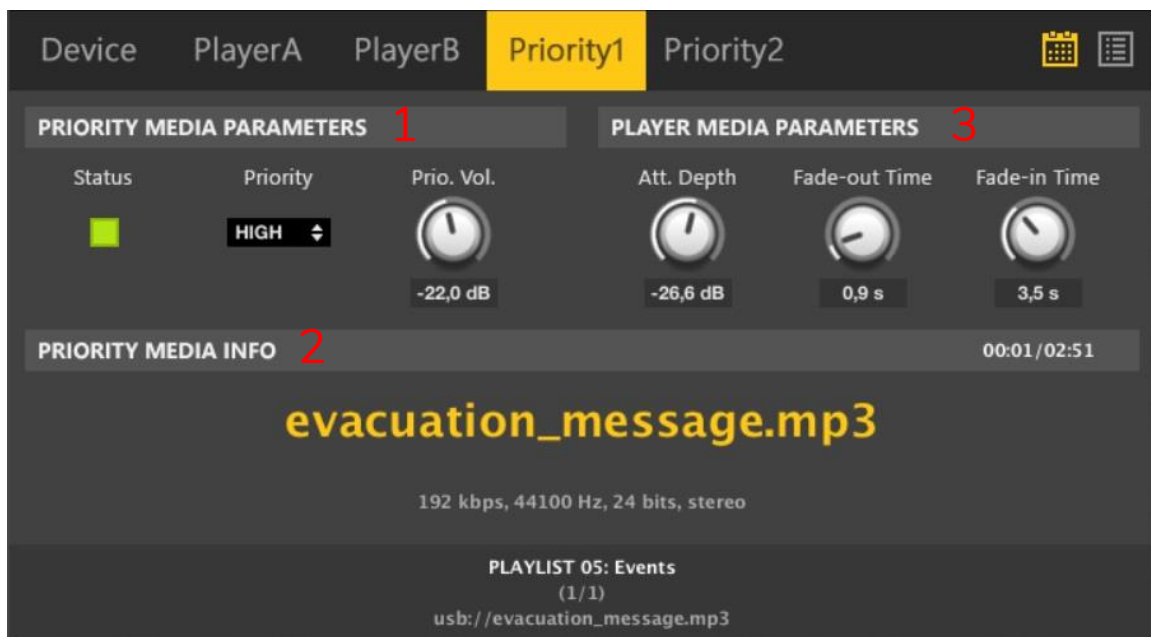

1. **PRIORITY MEDIA PARAMETERS** (parameters affecting the priority media that the module will manage and play in the destination players: A, B or both):

- **STATUS LED:** when lit (green), means the module is currently active (playing a priority media), after being triggered by an event
- **PRIORITY (LOW/HIGH):** priority level of a module when compared to the other module. This priority level defines how both modules will behave when trying to trigger them at the same time with the same destination player (A, B or both).

Examples:

- One Priority Module (e.g. P1) has HIGH priority level and the other module (e.g. P2) has LOW priority level, and both are triggered by events to the same PLAYER destination (A, B or both):
 - If P1 is triggered, P1 will start to play its priority for the time defined in its triggering event. During that time, if then P2 is triggered, P2 will be queued until P1 event is over. Then, P2 will really activate its event and play its priority media
 - If P2 is triggered and playing its priority media, and then P1 is triggered, it will stop and discard P2 playback and P1 will start its own priority media playback
- P1 and P2 have both the same priority level: after one of them is already triggered and playing, the second one that is triggered will be queued and will wait until the first one finishes its event, to start then to play its own priority media
- **PRIO VOL:** volume at which the priority media will be played at the destination players (A, B or both, defined by the triggering event). This volume **is independent from the PLAYERS A / B own volume control (new feature, from ENM v4.05r1)**

2. **PRIORITY MEDIA INFO:** when a module is active (STATUS LED ON), playing a priority media, this section will show its information (file name, tags, encoding information, etc.)

3. PLAYER MEDIA PARAMETERS (parameters affecting the program media that is currently being played in the destination player, when the priority media overrides it):

- **ATT DEPTH:** attenuation applied to the program media, to mix it with the incoming priority media. -60 dB (minimum value) is equivalent to a MUTE of the program media
- **FADE-OUT TIME:** time interval that the attenuation attack ramp will take to gradually set the program media to the audio level defined by ATT DEPTH, starting at the triggering moment
- **FADE-IN TIME:** time interval that the attenuation release ramp will take to gradually set back the program media to its previous audio level, after the module's priority event is over

10.1.6. DUO-NET PLAYLIST BANK section

PLAYERS A and B can load and play audio media from different locations:

- USB local memory device: connected to the DUO-NET USB slot
- SD/SDHC card local memory device: connected to the DUO-NET SD/SDHC slot
- Local Area Network media: stored in a folder of a computer belonging to the same LAN as the DUO-NET device
- Internet streaming media: directly from the Internet, accessing to it via the Internet network gateway (gateway IP must be configured in the DUO-NET's network parameters window)

The audio media must be compatible with any of these formats: mp3, ogg, AAC, WAV o FLAC.

The way PLAYER A and B are configured to load and play audio media is by means of the PLAYLIST BANK, which is shown clicking on this icon:



By default, the playlist bank will show this information, with the first two playlist positions, out of the 99 available, already pre-configured (but editable by the user):

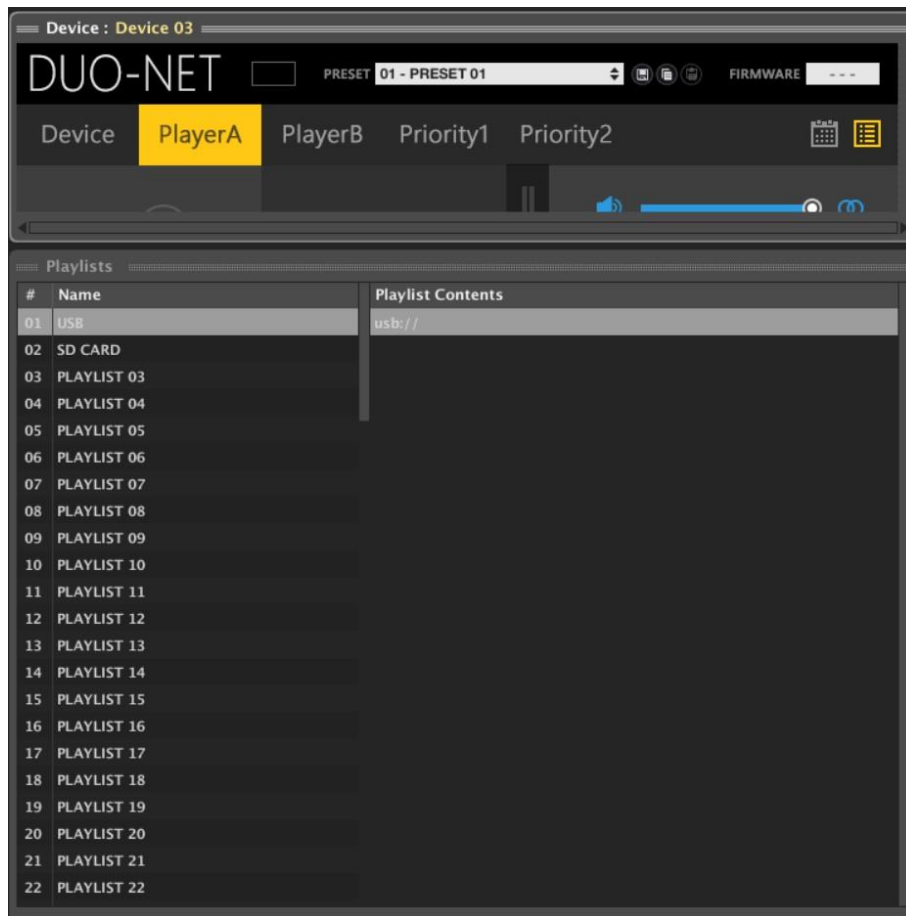

Each position in the playlist bank has an index number, a playlist name and a list of items (Playlist Contents) which must point to valid audio media. By default:

POSITION NUMBER	PLAYLIST NAME	PLAYLIST CONTENTS (items)
01	USB	usb://
02	SD CARD	mmc://
03	PLAYLIST 03	empty
...		
99	PLAYLIST 99	empty

Playlists 01 and 02 are pointing, by default, to the media stored in USB and SD storage devices that may be connected to the DUO-NET front panel slots. That is an easy way to directly access the audio media in those kind of devices without the need to reprogram the unit.

Every playlist in the bank can be renamed (Right-click + Edit) and repositioned (Right-click + Move Up / Move Down) in the list index:

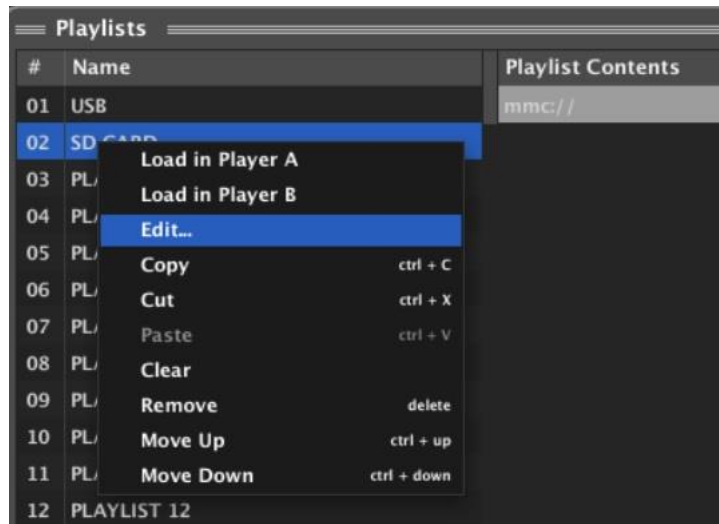

And every playlist in the bank can include a list of items, each one pointing to locations of valid audio media. For instance, these are 9 items that have been manually included in playlist #37:

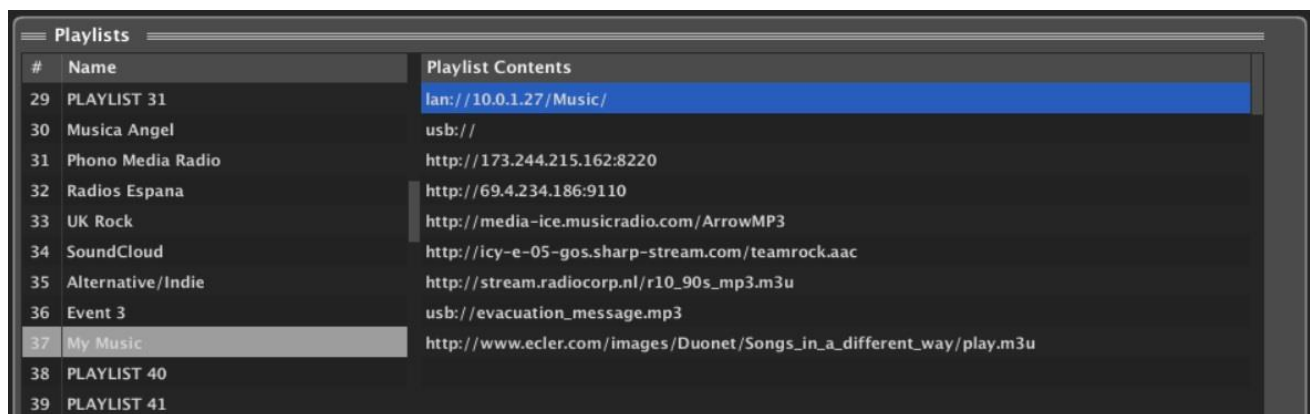

When one playlist is loaded in player A or B, DUO-NET will check the list of items included in it and will create a play queue just including the ones which have been found and are valid (compatible).

In the next example, we load playlist #37 in player B:

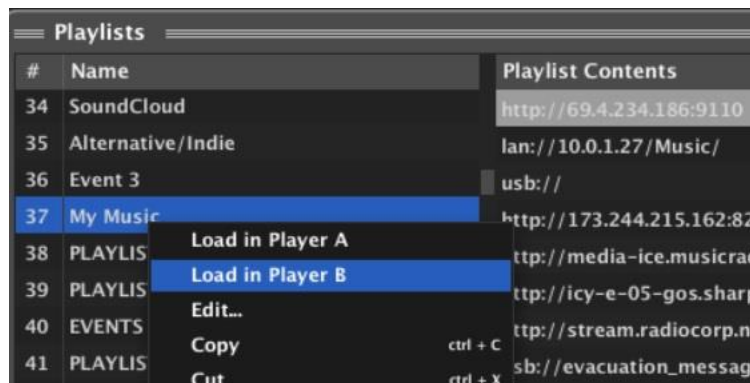

or

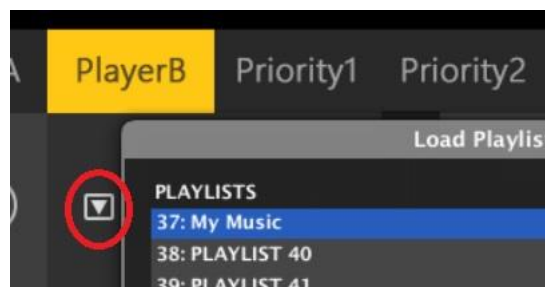

Then, player B will check it and create the play queue, which in this case will include every valid streaming source and individual audio track that has found and checked among the 9 locations (or URLs) defined by the nine items in the playlist. In this case, a total of 175 items:

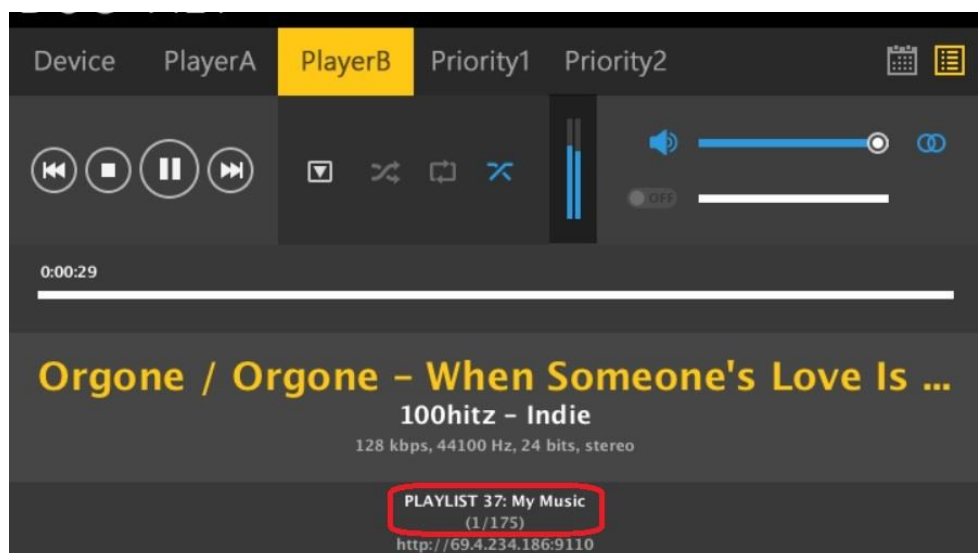

Activating the PLAY function will start to play the media at the first position in the play queue (or a random position media when in RANDOM PLAY mode), and NEXT / PREV keys will allow to skip it and move to the next or previous media in the queue.

Adding and editing items in a position in the Playlist Contents list is done by mouse double click or mouse right-click + Add New, Edit or Insert New options:

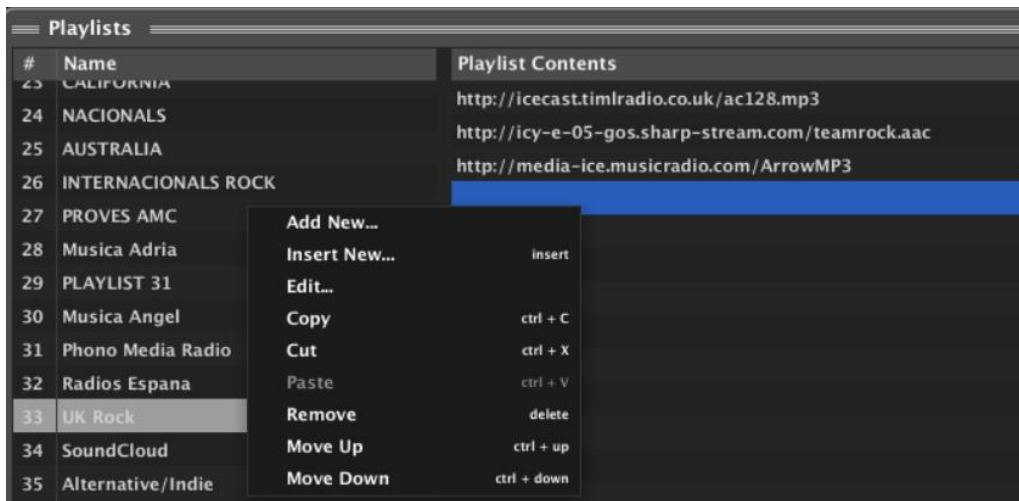

And this is the edit window that will open up:

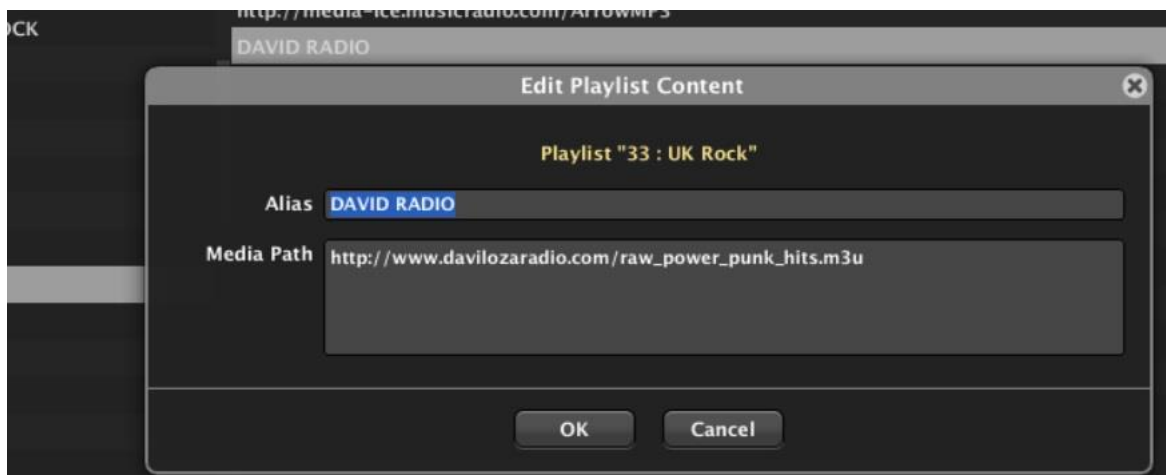

The Media Path is a mandatory field, but the Alias field is optional. If you enter a text in the Alias field, this is the name that will be shown in the Playlist Contents list, as well as in the player A or B info when this item is under playback:

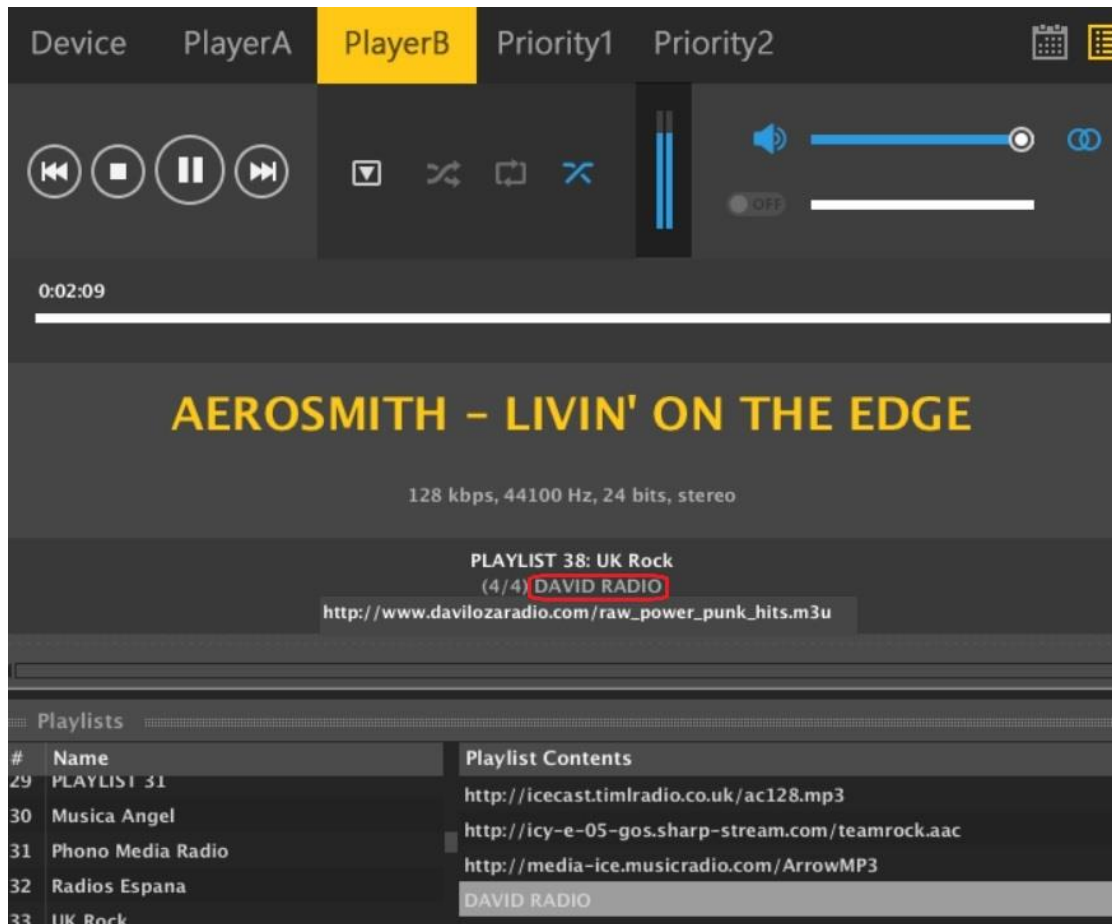

If no text is entered in the Alias field, then just the Media Path will be shown in the Playlist Contents list.

Each playlist in the bank of 99 playlists of the DUO-NET, has a dedicated Playlist Contents list, which can include more than 2.000 items. The Media Path field of each individual item in this list could be any of these possible options (some examples):

Media Path	Media Location	Items included in the play queue (just valid audio media)
usb://	USB storage device, root folder	Media stored in the USB root folder and up to the third level of sub-folders in it
mmc://	SD card storage device, root folder	Media stored in the SD card root folder and up to the third level of sub-folders in it
usb://musicfolder/jazz	USB storage device, \musicfolder\jazz folder	Media stored in the USB device \musicfolder\jazz folder and up to the third level of sub-folders in it
mmc://musicfolder/jazz	SD card storage device, \musicfolder\jazz folder	Media stored in the SD card \musicfolder\jazz folder and up to the third level of sub-folders in it
mmc://evacuation_message.mp3	SD storage device, root folder	mp3 single file named evacuation_message.mp3
usb://evacuation_message.mp3	USB storage device, root folder	mp3 single file named evacuation_message.mp3
lan://10.0.1.27/Music/	Folder in a computer within the DUO-NET LAN	Media stored in the computer with IP 10.0.1.27 , \Music folder and up to the third level of sub-folders in it
lan://10.0.1.27/Music/love_me_tender.mp3	Folder in a computer within the DUO-NET LAN	mp3 single file named love_me_tender.mp3 stored in the computer with IP 10.0.1.27 , \Music folder
usb://...path.../my_collection.m3u mmc://...path.../my_collection.m3u lan://...path.../my_collection.m3u	Defined by the m3u playlist file	Media pointed by my_collection.m3u playlist ...path... is the folder path where the m3u file is located

usb://...path.../my_songs.m3u8 mmc://...path.../my_songs.m3u8 lan://...path.../my_songs.m3u8	Defined by the m3u8 playlist file	Media pointed by my_songs.m3u8 playlist ...path... is the folder path where the m3u8 file is located
usb://...path.../best_of_rock.pls mmc://...path.../best_of_rock.pls lan://...path.../best_of_rock.pls	Defined by the pls playlist file	Media pointed by best_of_rock.pls playlist ...path... is the folder path where the pls file is located
http://www.ecler.com/music/party_songs/party.m3u	Defined by the m3u playlist file	Media pointed by party.m3u playlist, and located in a Internet url (corporate web, etc.)
http://www.ecler.com/music/party_songs/party.pls	Defined by the pls playlist file	Media pointed by party.pls playlist, and located in a Internet url (corporate web, etc.)
http://65.60.19.42:8040/	Real-time Internet streaming	Media served by an Internet audio streaming service with url http://nnn.nnn.nnn.nnn:port (in the example http://65.60.19.42:8040/)
http://stream1.megarockradio.net:8240	Real-time Internet streaming	Media served by an Internet audio streaming service with url http://url:port
http://195.55.74.211/cope/rockfm.mp3	Real-time Internet streaming	Media served by an Internet audio streaming service with url http://url/nnnn.mp3
http://208.92.53.90:443/LOS40_SC	Real-time Internet streaming	Media served by an Internet audio streaming service with url http://url/folder
http://media_musicradio.com/channel01.m3u	Real-time Internet streaming	Media served by an Internet audio streaming service, a playlist with url http://url/playlist.m3u
etc...		

10.1.7. DUO-NET EVENTS section

A DUO-NET event is a software routine converting a control input signal (GPI port, front panel or infrared remote keys, UCP control panels buttons, time scheduler, etc.) in an action which could affect the value of a parameter in the DUO-NET: PLAY, STOP, PAUSE, etc. function in a player, load a Preset, load a playlist in player, etc.

Clicking on the EVENTS icon displays the **Events list** in the bottom of the screen:

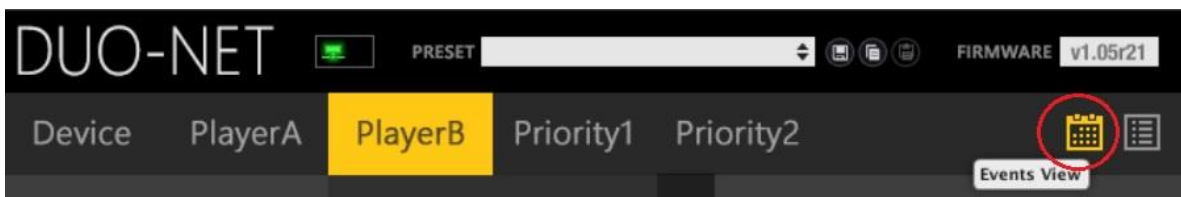

The list can include a maximum of 64 events. By default, a DUO-NET has 20 of them already created, driving the selection of the first 5 playlists in the bank, for both players (A and B) and using F1 to F5 keys in the DUO-NET front panel and the IR remote control. Of course, these events can be edited or deleted if desired.

#	Name	Source	Target
01	EVENT 01	Front Panel F1, Direct, Player A	Playlist 01 – USB, Player A
02	EVENT 02	Front Panel F2, Direct, Player A	Playlist 02 – SD CARD, Player A
03	EVENT 03	Front Panel F3, Direct, Player A	Playlist 03 – PLAYLIST 03, Player A
04	EVENT 04	Front Panel F4, Direct, Player A	Playlist 04 – PLAYLIST 04, Player A
05	EVENT 05	Front Panel F5, Direct, Player A	Playlist 05 – PLAYLIST 05, Player A
06	EVENT 06	Front Panel F1, Direct, Player B	Playlist 01 – USB, Player B
07	EVENT 07	Front Panel F2, Direct, Player B	Playlist 02 – SD CARD, Player B
08	EVENT 08	Front Panel F3, Direct, Player B	Playlist 03 – PLAYLIST 03, Player B
09	EVENT 09	Front Panel F4, Direct, Player B	Playlist 04 – PLAYLIST 04, Player B
10	EVENT 10	Front Panel F5, Direct, Player B	Playlist 05 – PLAYLIST 05, Player B
11	EVENT 11	IR Remote F1, Direct, Player A	Playlist 01 – USB, Player A
12	EVENT 12	IR Remote F2, Direct, Player A	Playlist 02 – SD CARD, Player A
13	EVENT 13	IR Remote F3, Direct, Player A	Playlist 03 – PLAYLIST 03, Player A
14	EVENT 14	IR Remote F4, Direct, Player A	Playlist 04 – PLAYLIST 04, Player A
15	EVENT 15	IR Remote F5, Direct, Player A	Playlist 05 – PLAYLIST 05, Player A
16	EVENT 16	IR Remote F1, Direct, Player B	Playlist 01 – USB, Player B
17	EVENT 17	IR Remote F2, Direct, Player B	Playlist 02 – SD CARD, Player B
18	EVENT 18	IR Remote F3, Direct, Player B	Playlist 03 – PLAYLIST 03, Player B
19	EVENT 19	IR Remote F4, Direct, Player B	Playlist 04 – PLAYLIST 04, Player B
20	EVENT 20	IR Remote F5, Direct, Player B	Playlist 05 – PLAYLIST 05, Player B

Editing existing events or creating new ones can be accessed by opening the context menu in the list (mouse right-click):

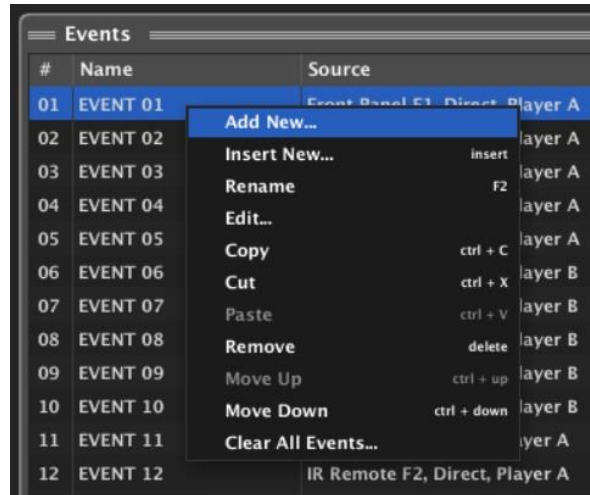

An event can have any of these possible control trigger signals (Event Source):

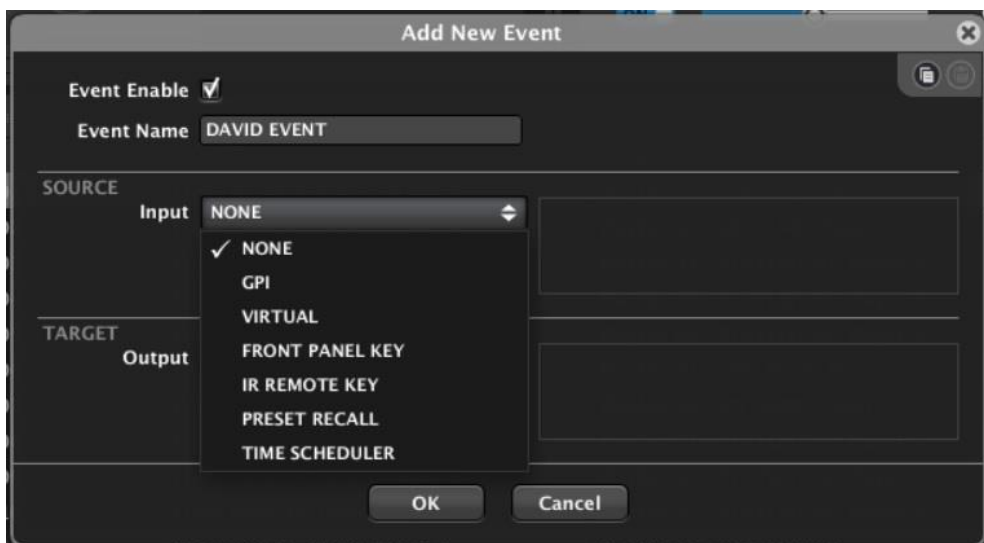

- **GPI:** a GPI can be activated by closing a contact between terminals +10VDC and n, where n can be GPI 1, 2, 3 or 4 (example activating GPI 3)

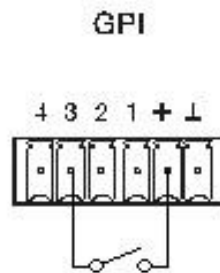

If GPI is selected as the event source, you need to specify the GPI port number and the DIRECT/REVERSE polarity:

- DIRECT: for rising edge-triggering, from 0VDC to 10VDC (active status is 10VDC)
- REVERSE: for falling edge-triggering, from 10VDC to 0VDC (active status is 0VDC)

GPIs BINARY MODE (4-bit combinations): UNDER CONSTRUCTION

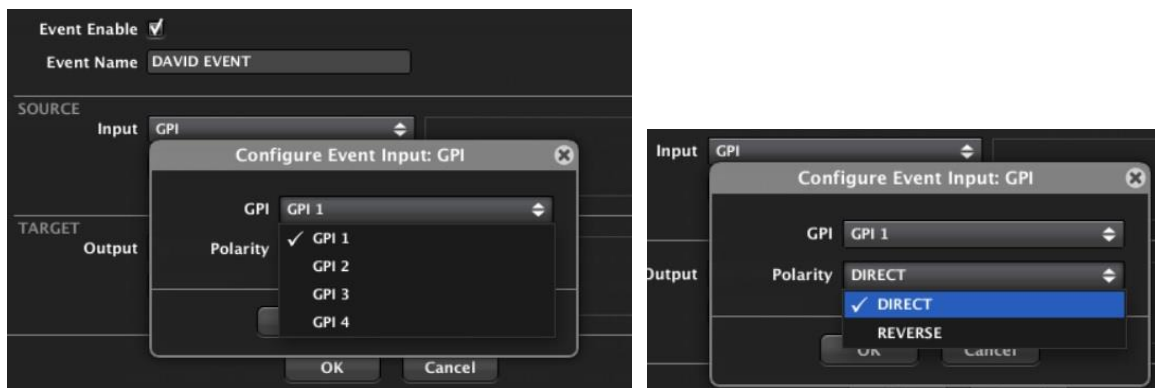

- **VIRTUAL:** a virtual control can be the trigger linked to a key (button) in a UCP panel.

If a UCP virtual control is selected as stimulus, we must specify which one among the 64 available in the DUO-NET is selected, and how the stimulus is interpreted, DIRECT / REVERSE (when you press or release the UCP button), as in the previous case:

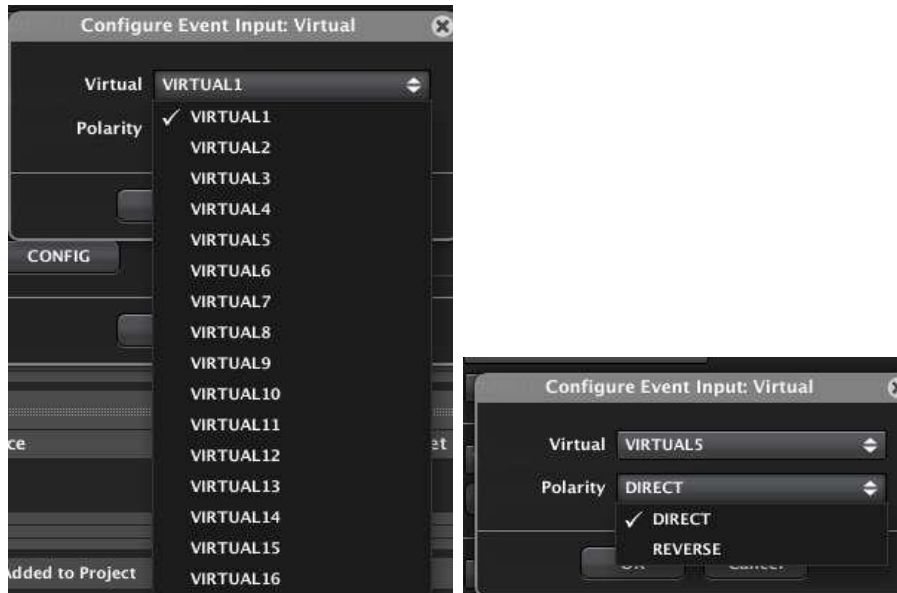

- **FRONT PANEL KEY:** F1 to F5 keys in the front panel key, in combination with PLAYER A and/or B selected by means of the PLAYER A / B front panel keys:

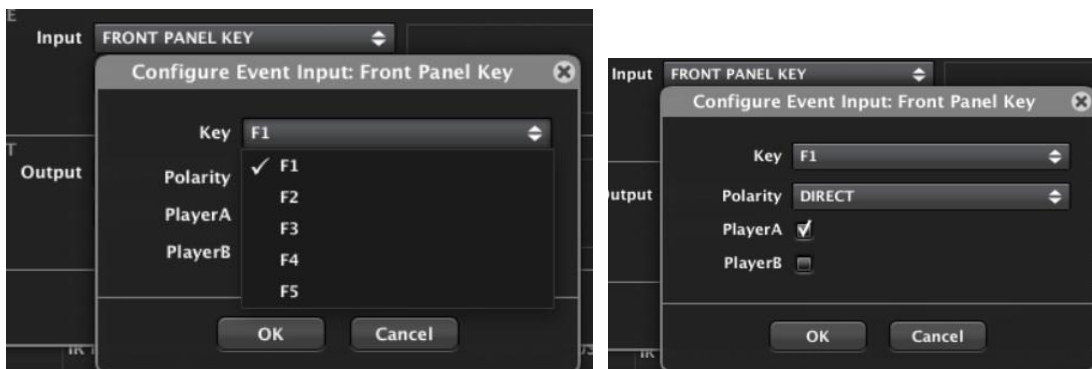

- **IR REMOTE KEY:** F1 to F5 for player A or F1 to F5 for player B keys in the infrared remote:



- **PRESET RECALL:** the event will be triggered right after a given preset is recalled:

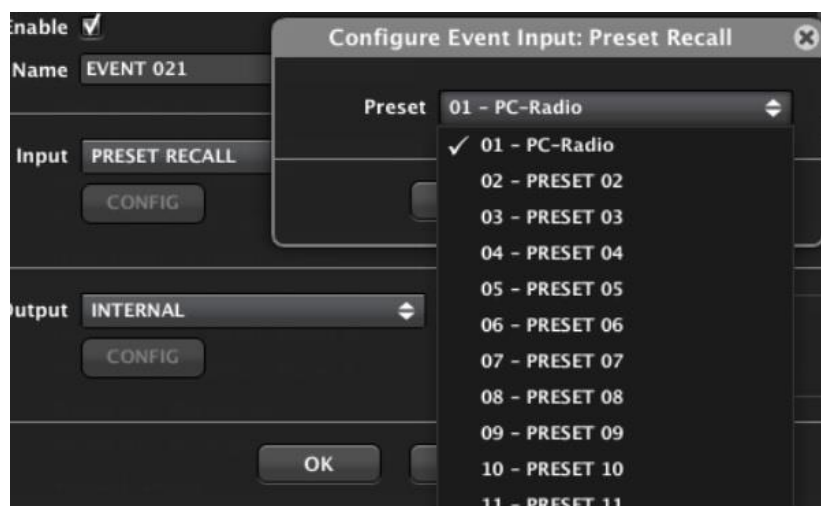

- TIME SCHEDULER:** this type of event receives its input stimulus according to a calendar with date and time of onset, duration, days of the week it must be activated or not, repetition by time interval or number of repetitions and end date. The DUO-NET has an internal clock that allows the management of such events, which can be as well synchronized with NTP service (Network / Internet clocks):

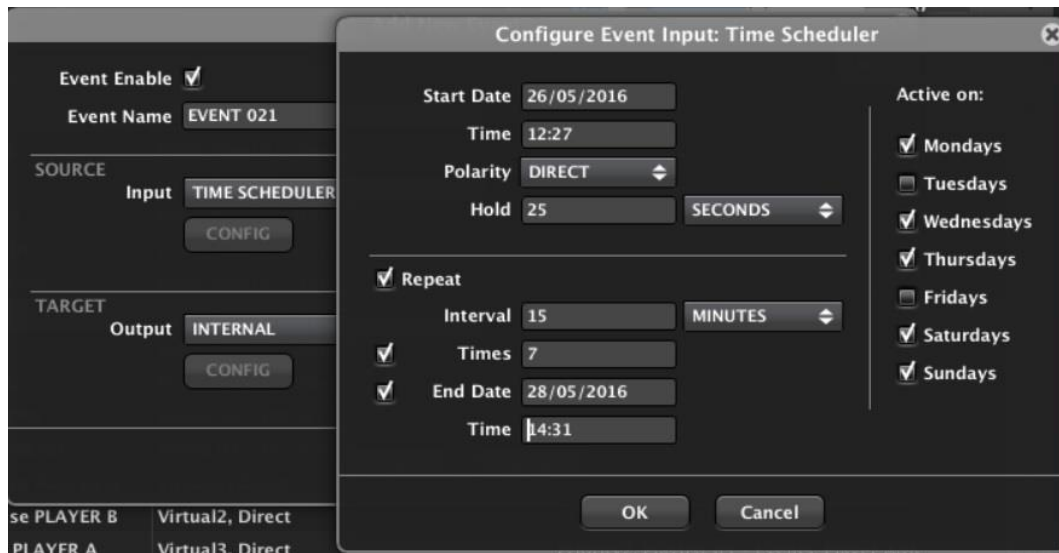

- TIME SCHEDULER (BASIC):** it's a simplified version of a scheduler, with a much easier way to configure events with daily repetition (**new feature, from ENM v4.05r1**)

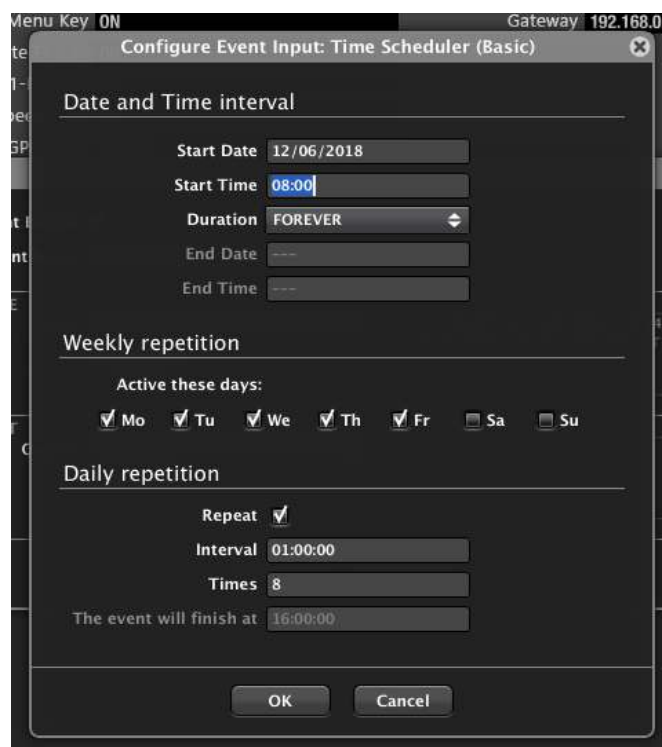

Combining Time Scheduler with Time Scheduler Basic opens up a new range of possibilities. For example, some calendar exceptions can be created (festive days, non-workable days, etc.) in a simple way. Program an annual calendar in a simple way, using Time Scheduler Basic, and also create events with Time Scheduler, recalling presets for festive days or holidays period where the previous basic schedule event is disabled.

Once defined the Source or trigger for the event, we must define as well the Target or action to execute when the event is triggered. These are the possible Targets for an event:

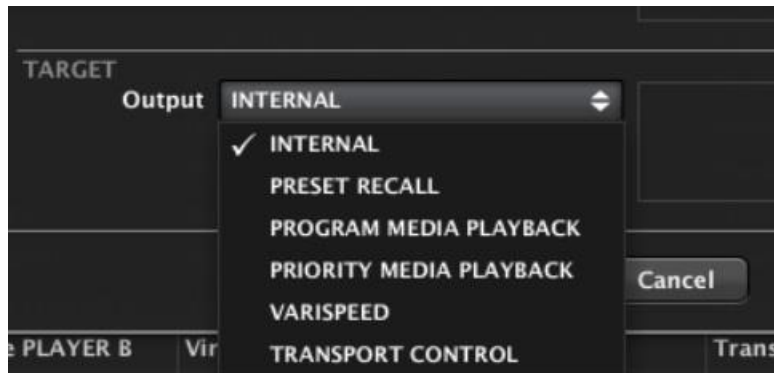

- **PRESET RECALL:** a given preset out of the 20 available can be recalled:



- **PROGRAM MEDIA PLAYBACK:** selects a playlist from the DUO-NET bank, loads it in PLAYER A and/or B and sets a playback mode for it (CONTINUE with the current PLAY / PAUSE status, force PLAY mode or force STOP mode):

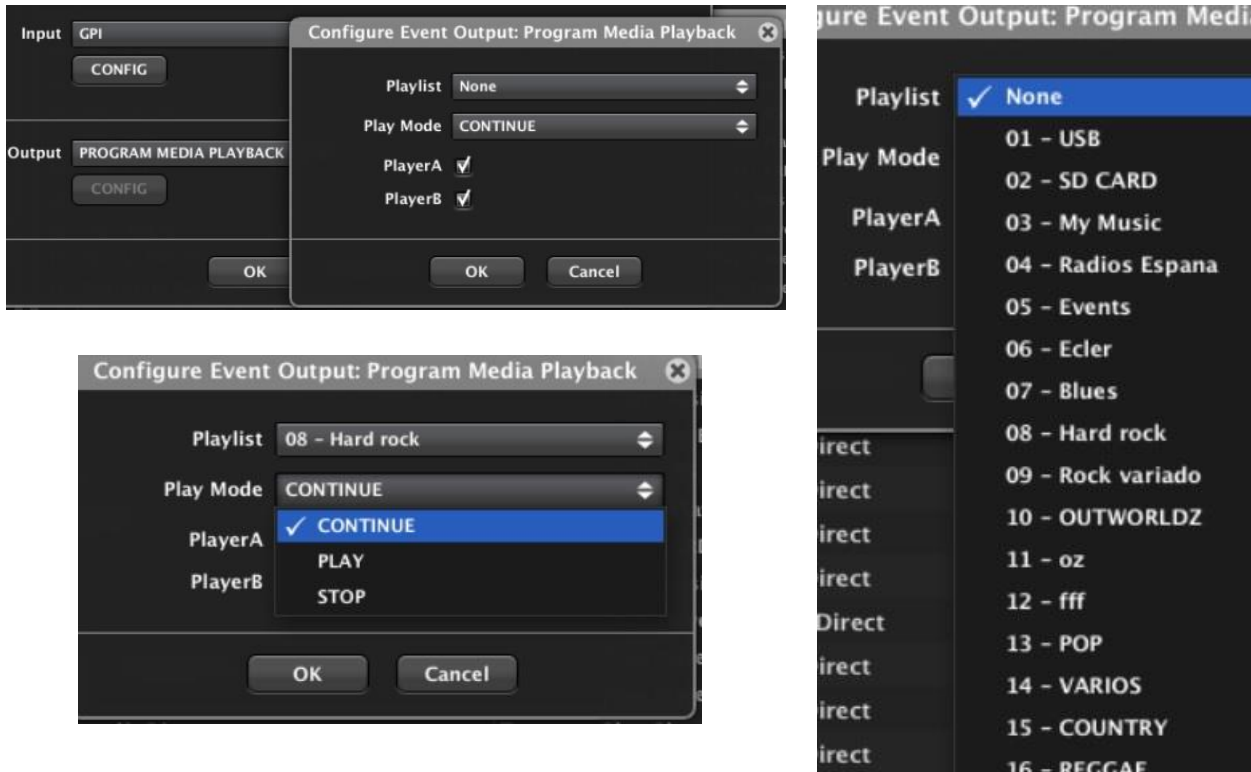

- **PRIORITY MEDIA PLAYBACK:** selects a playlist from the DUO-NET bank, loads it in PRIORITY module 1 or 2, decides the PLAYER to be affected by the priority audio (A and/or B) and sets the Triggering Mode for the priority audio:

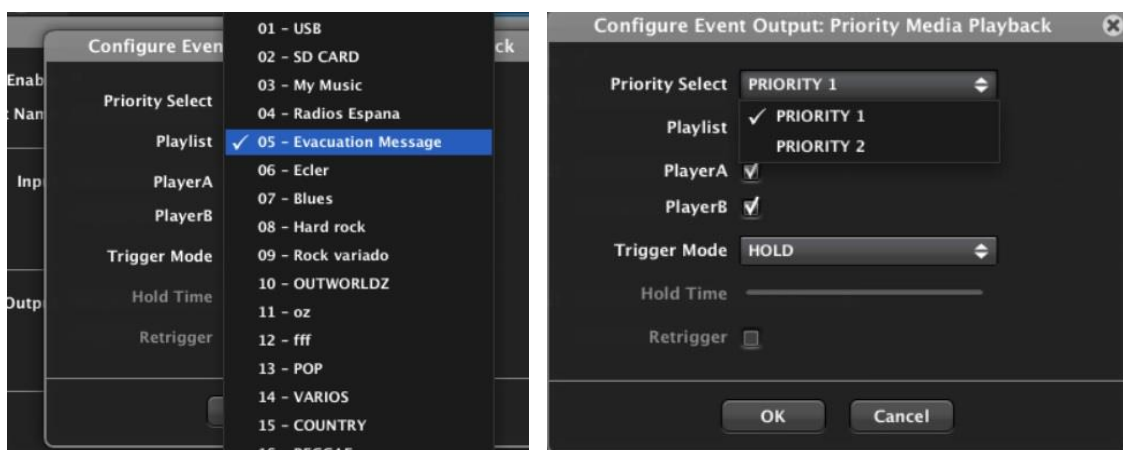

Trigger modes are:

- **HOLD:** the priority audio will be played in the destination players (A / B) as long as the trigger stimulus is active (e.g.: meanwhile an external contact that triggers a GPI is closed)

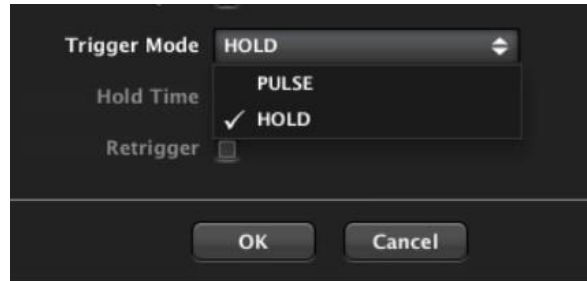

- **PULSE:** the priority audio will start playing in the destination players (A / B) when the trigger stimulus appears, and will keep playing for the time defined by the Hold Time parameter. When Retrigger option is enabled, a new trigger pulse happening during the Hold Time period will start the event again from zero, resetting as well the time counter

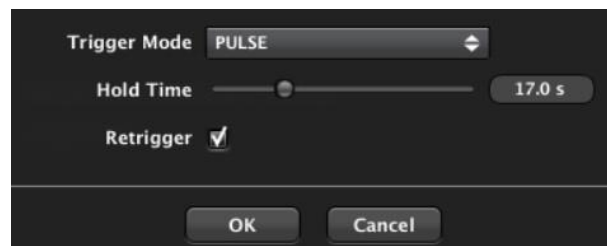

- **VARISPEED:** each time the trigger appears (e.g.: a push button is pressed, connected to a GPI, or a button in a UCP control panel is pressed), the event will speed up or down the track's tempo (bpm), a useful feature in fitness and similar applications. The bpm increment / decrement each time the event is triggered is defined by the Amount parameter:

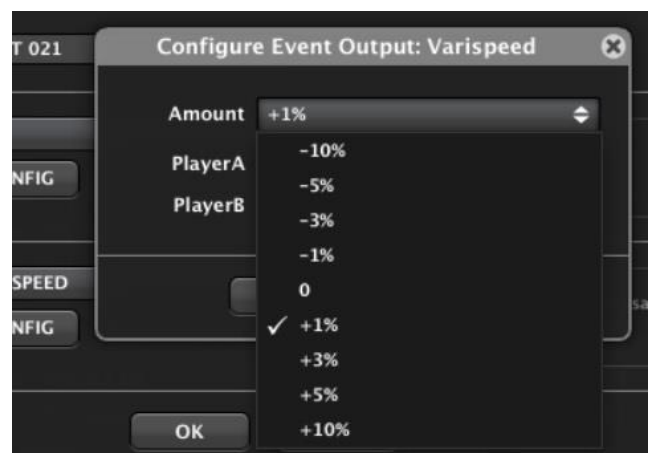

- **TRANSPORT CONTROL:** each time the trigger appears (e.g.: a push button is pressed, connected to a GPI, or a button in a UCP control panel is pressed), the event will activate a transport control function (PLAY / PAUSE / STOP, etc.) in PLAYER A and/or B:



Events enable / disable status is preset-dependant, if desired. This means that, when saving a preset, this status for all the existing events can be stored as part of the data stored in it, so that recalling a preset also restores the existing combination of enabled and disabled events at the time of saving.



10.1.8. DUO-NET UCP controls

These are some of most remarkable UCP control functions that the DUO-NET supports, some of them used in this example panel (see **User Control Panels** chapter for further details regarding custom-made graphical screens for the remote control of EclerNet installations):

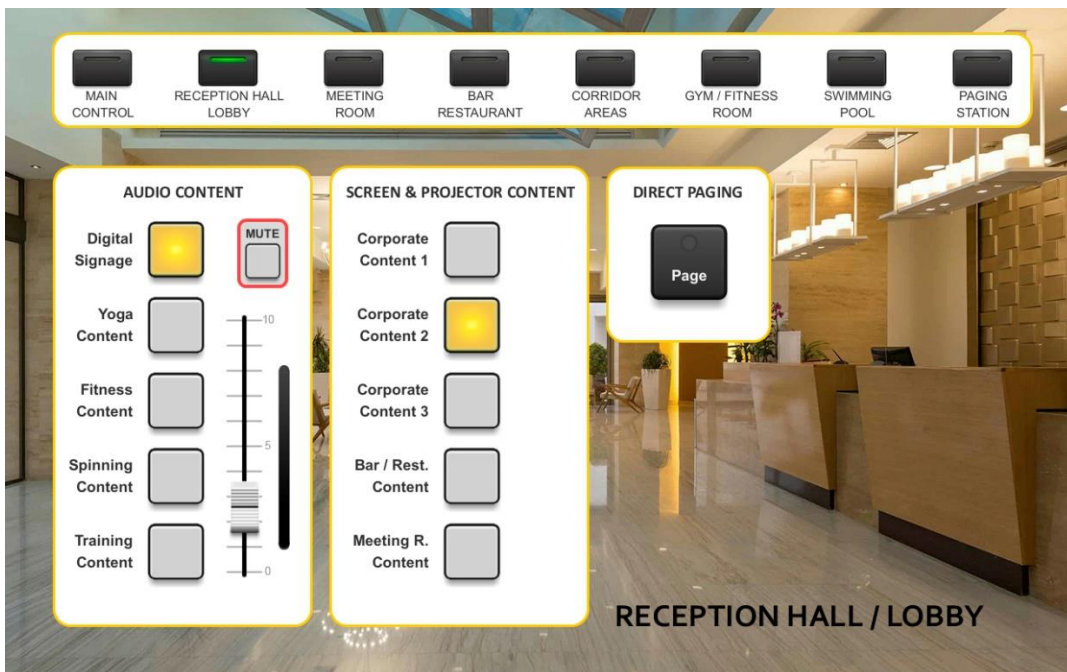

10.1.8.1. Dynamic Texts

(will show numeric or text information in real-time):

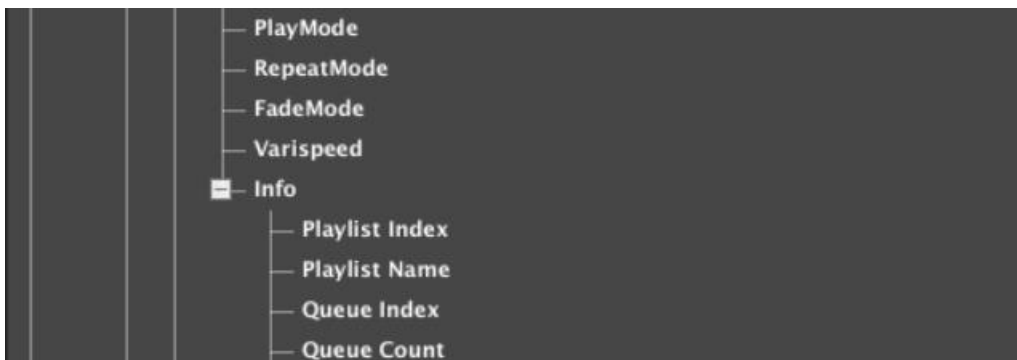
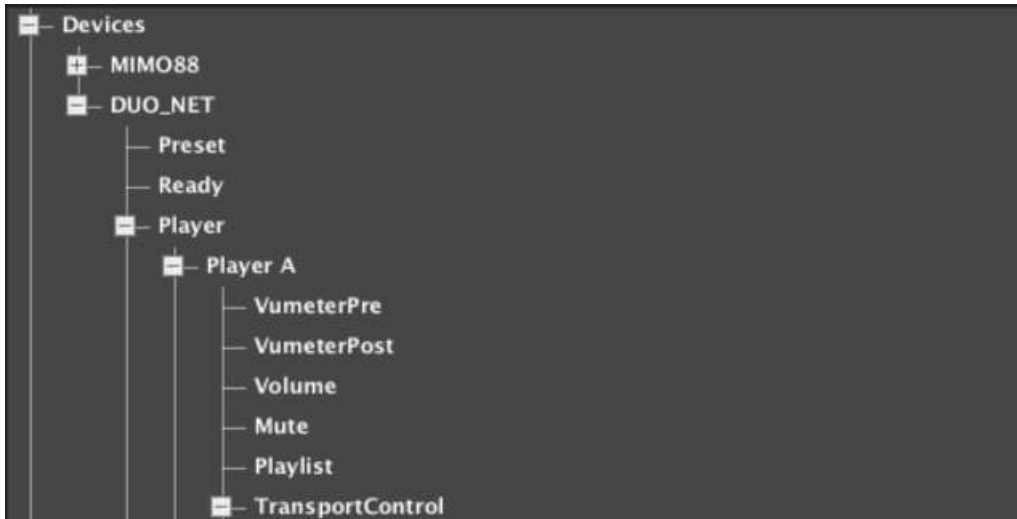

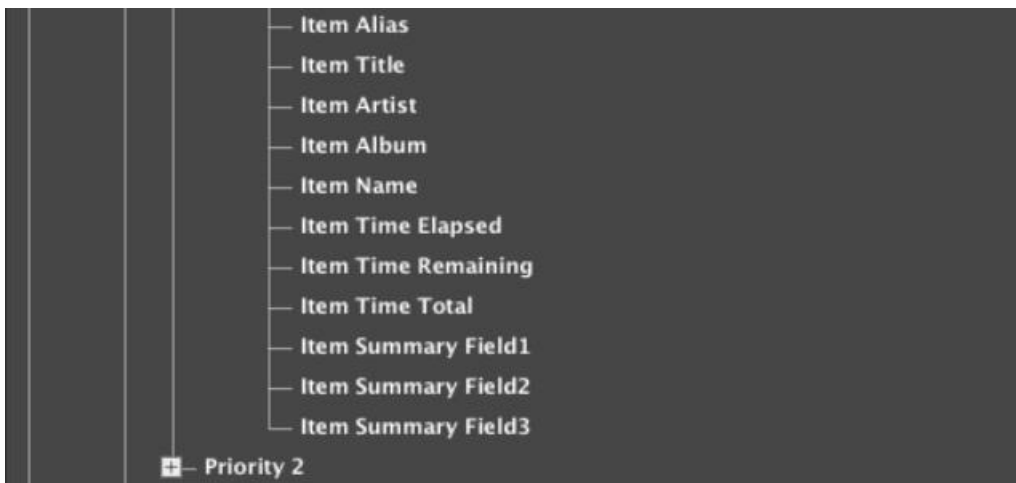
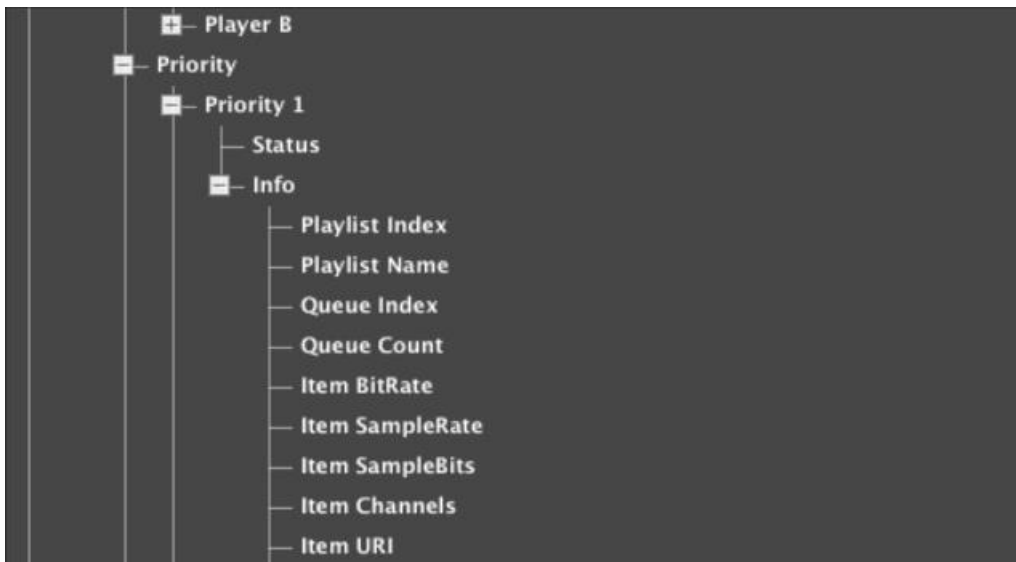
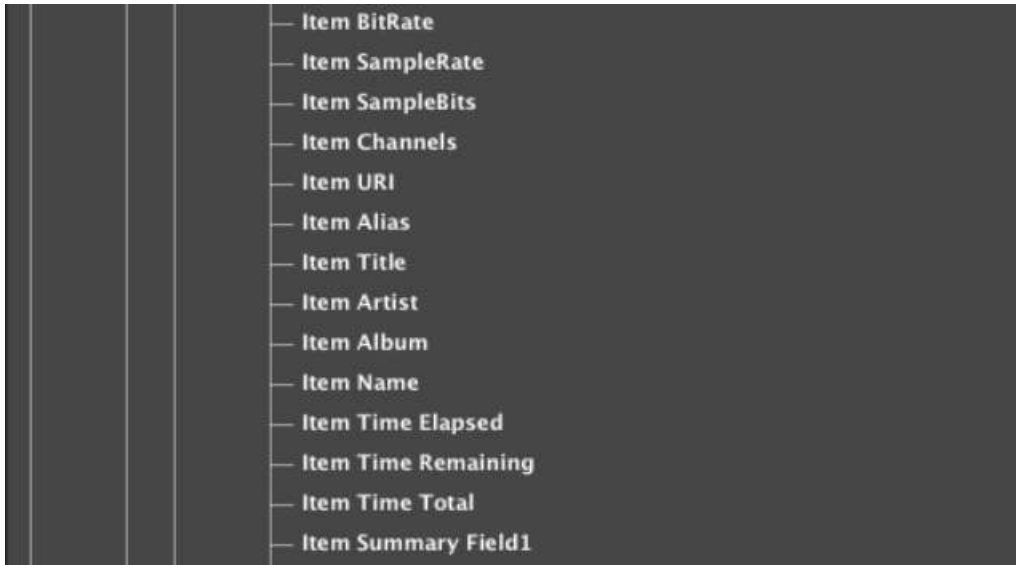

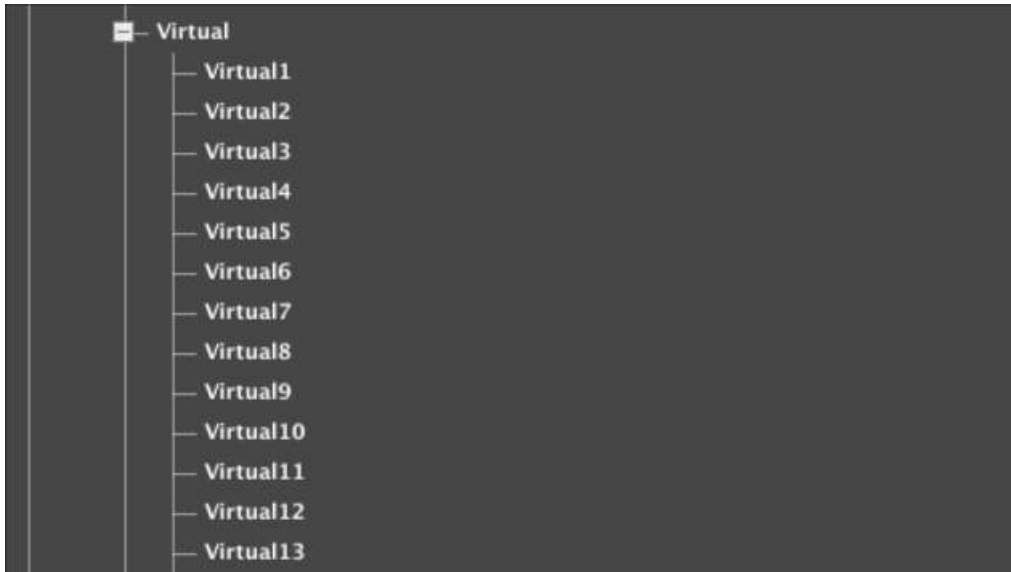

Remarks:

- **"Info/Playlist Index"**: playlist in use, number (position) from 1 to 99 in the playlist bank
- **"Info/Playlist Name"**: playlist in use, name
- **"Info/Queue Index"**: item under reproduction, position in the current play queue
- **"Info/Queue Count"**: total number of items included in the current play queue
- **"Info/Item BitRate"**: item under reproduction, bitrate
- **"Info/Item SampleRate"**: item under reproduction, sample rate
- **"Info/Item SampleBits"**: item under reproduction, sample bits
- **"Info/Item Channels"**: item under reproduction, channels
- **"Info/Item Source"**: item under reproduction, source
- **"Info/Item URI"**: item under reproduction, URL
- **"Info/Item Alias"**: item under reproduction, Alias name
- **"Info/Item Title"**: item under reproduction, title tag
- **"Info/Item Artist"**: item under reproduction, artist tag
- **"Info/Item Album"**: item under reproduction, album tag
- **"Info/Item Name"**: item under reproduction, name tag
- **"Info/Item Time Elapsed"**: item under reproduction, elapsed time
- **"Info/Item Time Remaining"**: item under reproduction, remaining time
- **"Info/Item Time Total"**: item under reproduction, total time
- **"Info/Item Summary Field1"**: item under reproduction. Shows the first available information, within this list: Title, Alias, URL
- **"Info/Item Summary Field2"**: item under reproduction. Shows the first available information, within this list: Artist-Album, Artist, Album, Name
- **"Info/Item Summary Field3"**: item under reproduction. Shows, if available, Bitrate, SampleRate, SampleBits and Channels in a single text chain

10.1.8.2. Buttons

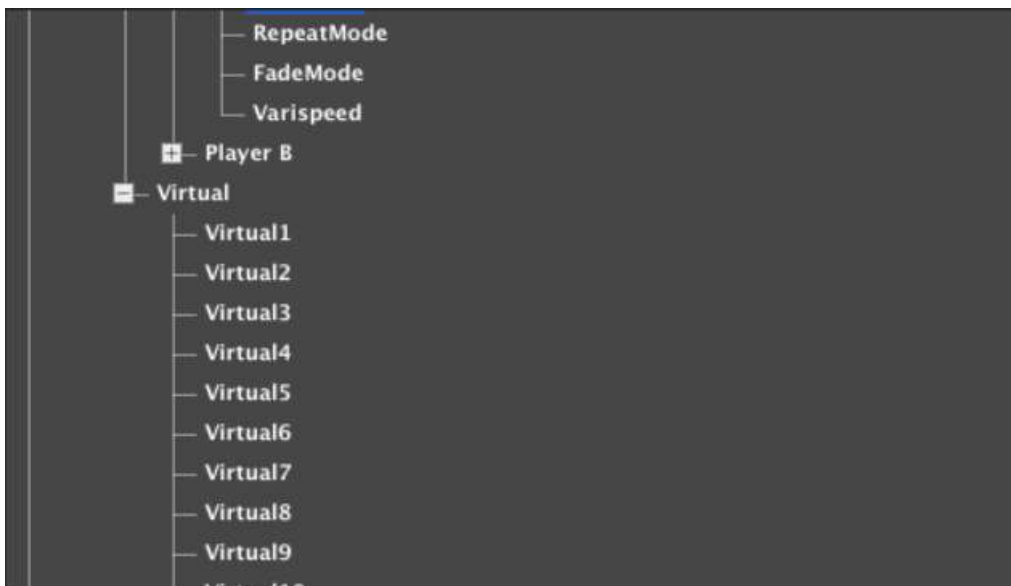
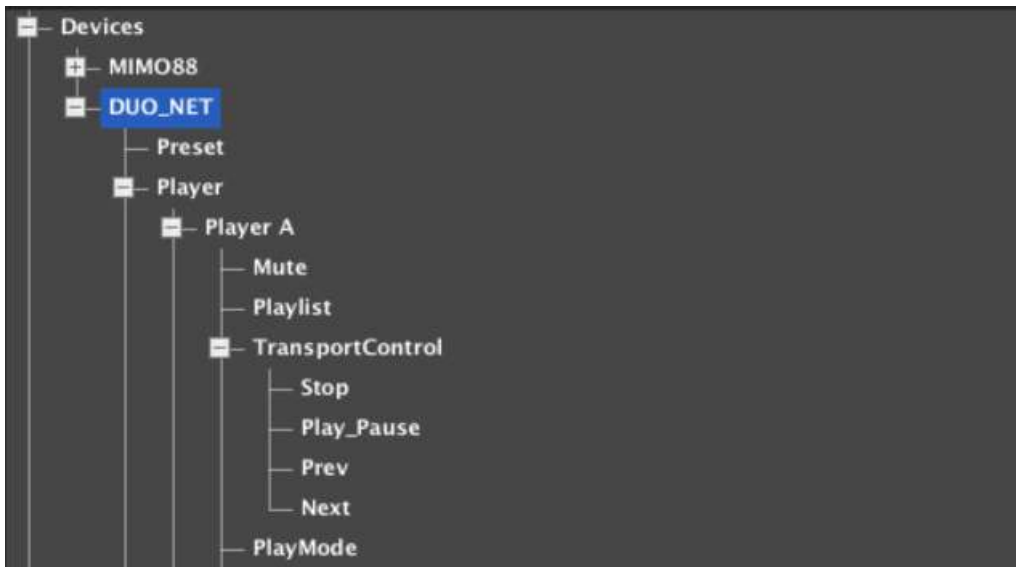

Remarks:

- **“PlayMode” parameter:** 0 = Sequential, 1 = Random. Admits BUTTON, BUTTON MULTI and BUTTON INC/DEC type controls. INC/DEC buttons will swap in circle fashion (0-1-0-1, etc, or seq - random - seq - random - etc.) after sequential button presses. LED controls can be linked to these numerical values to get on-screen feedback of the active mode

- **“RepeatMode” parameter:** 0 = Play all, 1 = Play one, 2 = Repeat all, 3 = Repeat one. Admits BUTTON, BUTTON MULTI and BUTTON INC/DEC type controls. INC/DEC buttons will swap in circle fashion (0-1-2-3-0-1-2-3-0, etc, or play all - play one - repeat all -repeat one - play all - play one - repeat all - repeat one - play all, etc.) after sequential button presses. LED controls can be linked to these numerical values to get on-screen feedback of the active mode
- **“FadeMode” parameter:** 0 = None, 1 = Cross Fade, 2 = Fade, 3 = Half Fade. Admits BUTTON, BUTTON MULTI and BUTTON INC/DEC type controls. INC/DEC buttons will swap in circle fashion (0-1-2-3-0-1-2-3-0, etc, or none - cross fade - fade - half fade - none - cross fade - fade - half fade - none, etc.) after sequential button presses. LED controls can be linked to these numerical values to get on-screen feedback of the active mode
- **“Varispeed” parameter:** Admits numerical values in the range from 0 to 100 (0 = -50%, 50 = 0%, 100 = +50%). Admits FADER, ROTARY, BUTTON, BUTTON MULTI and BUTTON INC/DEC type controls. LED controls can be linked to these numerical values to get on-screen feedback of the active mode

10.1.8.3. Faders and Rotaries



10.1.8.4. LED indicators

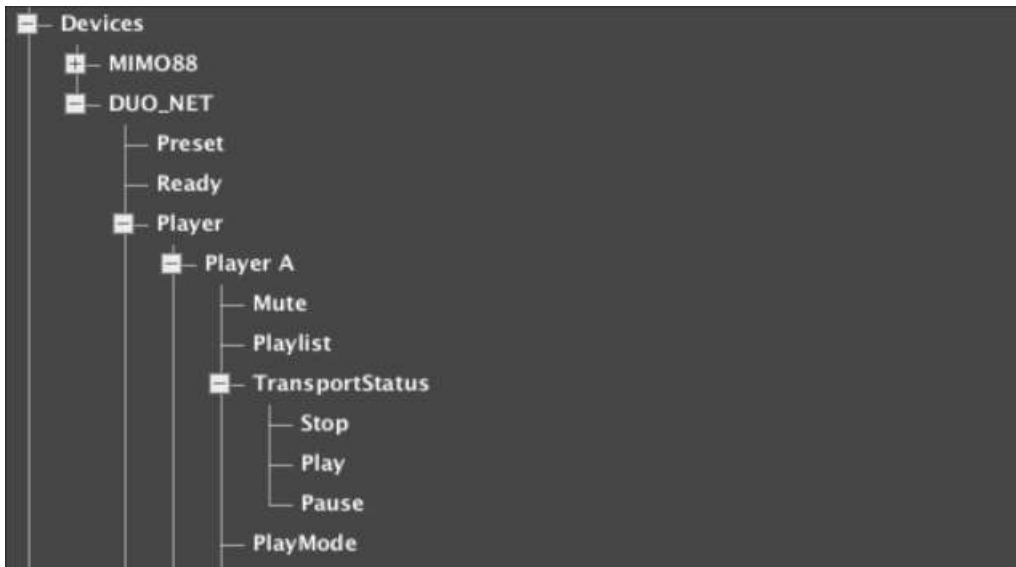

Remarks:

- **“PlayMode” parameter:** 0 = Sequential, 1 = Random. LED controls can be linked to these numerical values to get on-screen feedback of the active mode
- **“RepeatMode” parameter:** 0 = Play all, 1 = Play one, 2 = Repeat all, 3 = Repeat one. LED controls can be linked to these numerical values to get on-screen feedback of the active mode
- **“FadeMode” parameter:** 0 = None, 1 = Cross Fade, 2 = Fade, 3 = Half Fade. LED controls can be linked to these numerical values to get on-screen feedback of the active mode

11. EclerNet COMPATIBLE DEVICES: DANTE© protocol compatible devices

11.1. DN44BOB

11.1.1. DN44BOB introduction

The DN44BOB is a 4 x inputs and 4 x outputs DANTE© (Audio Over IP) Break Out Box (interface). It allows to convert 4 analogue audio signals into 4 DANTE© channels and send them into an Ethernet LAN, as well as to take 4 DANTE© channels from the Ethernet network and convert them to analogue audio signals. It includes 4 GPI control ports (0-10VDC) and 4 GPO control ports (NO/NC relays). DN44BOB can be used together with other EclerNet DANTE ready products or as a stand-alone DANTE interface, together with any audio device including analogue audio inputs and/or outputs.

DN44BOB programming and control is managed using EclerNet Manager, from a remote point of the Ethernet network it is connected to. Using EclerNet Manager it is possible to manage every parameter in the device, except for the DANTE routing, which is done using Audinate© Dante Controller software.

The back panel of the hardware device includes these terminals and controls:

- **RJ45 ETHERNET/DANTE:** Ethernet, EclerNet and DANTE interface port
- **IN1 to IN4:** analogue audio inputs, receiving 4 audio sources which will be converted to 4 Dante channels and sent to the network through the RJ45 connector
- **OUT1 to OUT4:** analogue audio outputs, which come from 4 Dante channels received in the unit from the network, through the RJ45 connector
- **GPO1 to GPO4:** 4 General Purpose Outputs, NC/NO relays
- **GPI1 to GPI4:** 4 General Purpose Inputs, 0 – 10 VDC, connectable to external devices such as contact closures, potentiometers, ECLER WpM / WPa series panels, 0 - 10 VDC power supply, etc
- **FD push button:** Factory Defaults restoration button

Note: GPI inputs and GPO outputs can be programmed to trigger some functions of the unit, such as:

- recall a Preset with an external WpM / WPa selector (GPI)
- activate/deactivate a MUTE control with an external physical switch (GPI)
- set a volume from an external physical control such as a WpM / WPa series panel or a potentiometer (GPI)

- activate a GPO (close / open a relay) connected to external devices (lights, GPI inputs, motors, etc.)

The front panel of the hardware device includes several indicators:

- **INPUTS:** 4 LEDs showing audio activity in the 4 audio analogue inputs, which will be converted to 4 Dante channels and sent to the network through the RJ45 connector
- **OUTPUTS:** 4 LEDs showing audio activity in the 4 audio analogue outputs, which come from 4 Dante channels received in the unit from the network, through the RJ45 connector
- **DATA LED:** shows a valid connection and data transfer with EclerNet Manager or other compatible control devices
- **DANTE LED:** shows no Dante connectivity (red), Dante activity as a MASTER device (green) or Dante activity as a SLAVE device (orange)
- **POWER LED**

Note: in a Dante Network one device must be the MASTER, delivering the MASTER clock for the digital audio transmission, and the rest of devices must be SLAVES, synchronised with the MASTER clock



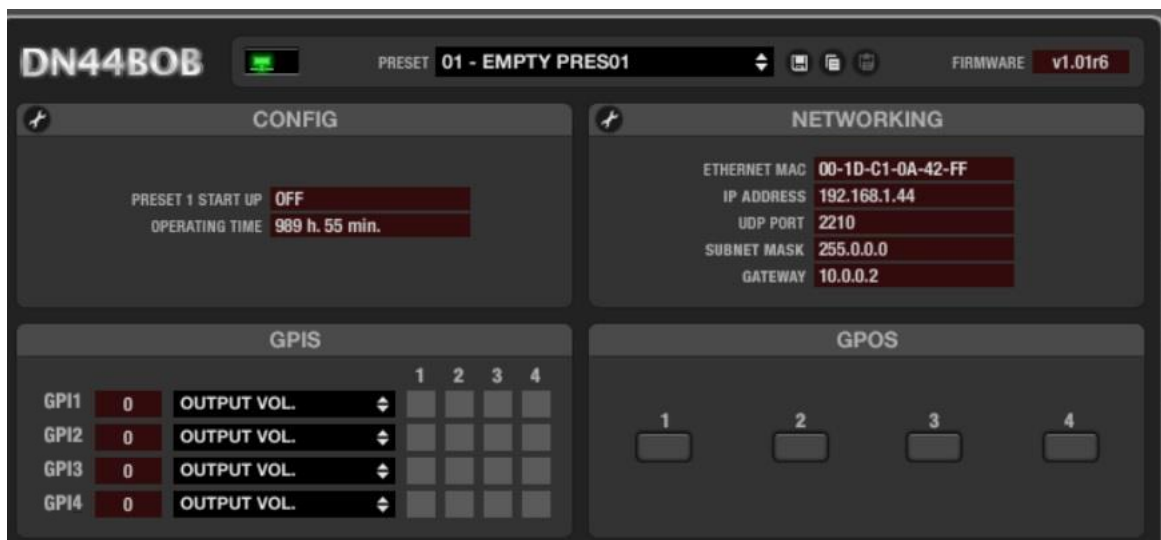

11.1.2. DN44BOB device detailed view, general section

The detailed view of a DN44BOB device has the following appearance:

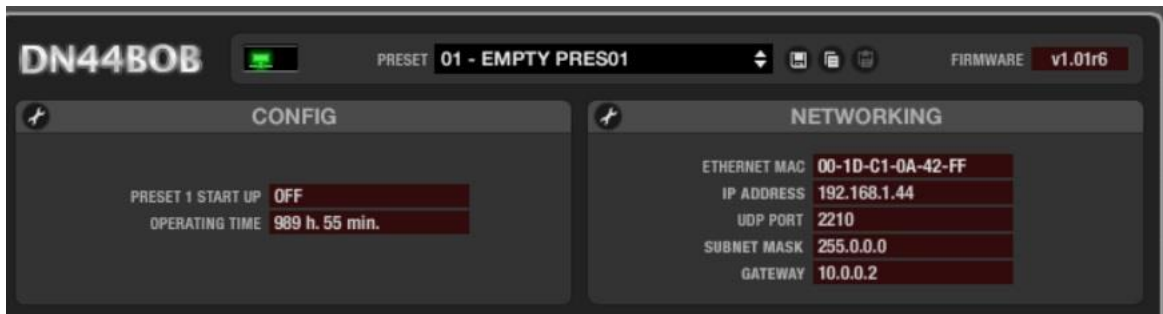

The top section of the detailed window provides the following items:

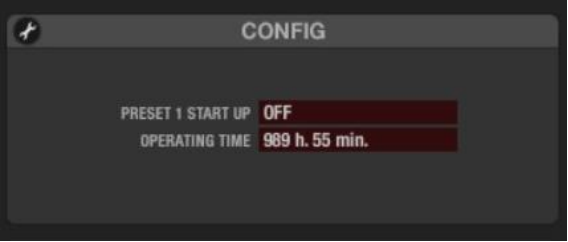
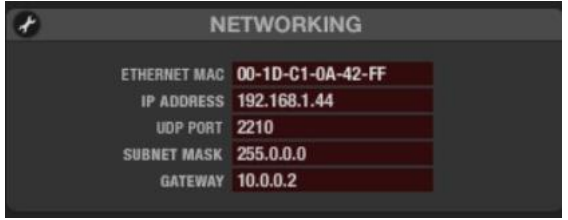

	Device model and name
	Status monitoring and alarms window. See Table of status monitoring and alarm icons
	Active Preset window: indicates the Preset currently active in the device
	Presets management icons (See (1)): <ul style="list-style-type: none"> • Save Device Preset: saves the current Preset in memory (click on the mouse left button) or in a folder on your PC (click on the mouse right button) • Copy Device Preset: copies the current Preset • Paste Device Preset: pastes the previously copied Preset
	Unit's firmware version

	<p>Device configuration. See (2)</p>
	<p>Network parameters configuration. See (3)</p>

(1) Save Device Preset (saves the current Preset).

Left-clicking this icon opens a window with the following options:



- **Name of the Preset** to save at the selected location, 1 to 5 (location number can't be changed)
- **Data saved in the Preset:** Inputs section, Outputs section, and GPOs status

The Preset stores just the data selected in the previous window, so that recalling the Preset only changes (rewrites) the data stored in this Preset, not affecting other parameters of the unit.

This ability to save "partial" Presets allows a great freedom of management. Example: two Presets including different INPUTs levels. By loading either of these two Presets during system operation, only such input levels will change, respecting the current outputs settings and the GPOs open or closed current status.

Right-clicking this icon opens a window with the following options:

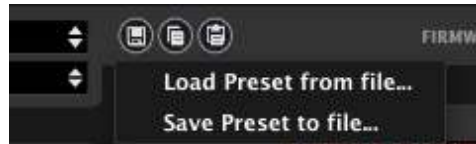

- **Load Preset from file:** lets you load a Preset stored on a hard drive, external USB memory, etc.
- **Save Preset from file:** lets you save a Preset on a hard drive, external USB memory, etc.

These two functions are very useful for copying in a DN44BOB unit a Preset coming from another unit currently offline, or from another Project or facility. Preset files are saved on disk with a ".DN44_preset" suffix.

(2) Device configuration.

Clicking on the configuration edit icon opens the following window:



- **Preset 1 Start Up: ON/OFF**
Allows to automatically retrieve the preset number 1 stored in the unit memory each time the equipment is initialized (the power supply is switched off and on again). This ensures the same starting conditions for your setup each time the device is turned on (at the beginning of the day, etc..)
The CONFIG window shows the status of the adjustments made, as well as the number of accumulated operating hours of the device (*OPERATING TIME*).

(3) Network parameters configuration.

Exactly the same window and same parameters than those available with Network Configuration in a device context menu:

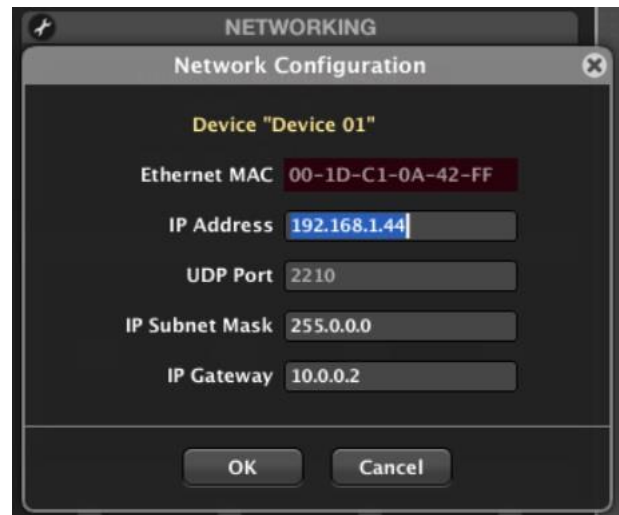

Next, section **GPIs** and **GPOs** allows to configure the function to be performed by the rear panel GPI ports and the GPO relays:



The unit's **GPI** ports (0-10 VDC control ports) on the rear panel are displayed as GPI 1 to 4. To the right of each of them is displayed the value of the signal (voltage) received on the central pin of each GPI port, read in real time (0 to 100 scale). A WPM / WPA VOL or WPMVOL-SR / WPM / WPAVOL-SR wall panel, or similar, connected to a GPI will deliver this full range, 0 to 100 values, when gestured.

For each of them, the drop-down menu allows to select the control function among the following options:



- **INPUT VOL.:** volume control of one or more audio inputs of the unit. The boxes of the targeted inputs must be checked: clicking with the mouse activates (green) or deactivates them. In the following example GPI #1 controls the volume of inputs 1 and 2:

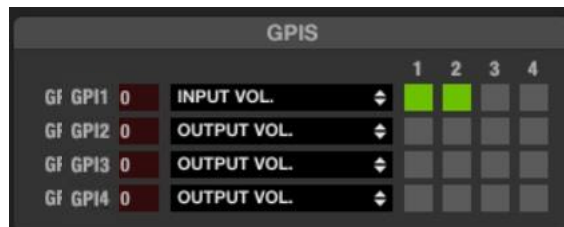

- **OUTPUT VOL.:** volume control of one or more audio outputs of the unit. The boxes of the targeted outputs must be checked: clicking with the mouse activates (green) or deactivates them. In the following example GPI #4 controls the volume of the outputs 1, 3 and 4:

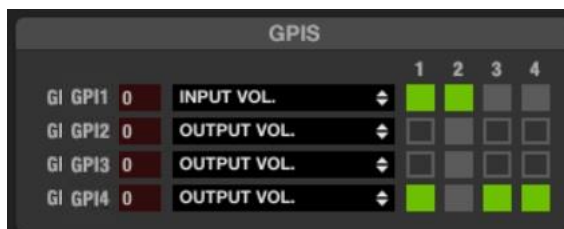

Note: when a LEVEL control (software fader) **and** a GPI are associated to control the volume of the same input or output, both are concatenated ("in series"), so that the highest level of one of them at a given time will determine the maximum volume control that can reach the other when set to its maximum position.

Examples, with a FADER (2) and GPI 1 controlling the channel 2 volume:

- GPI 1 at 100%: moving the FADER, it can control the channel 2 volume from 0 to 100%
- FADER at 100%: acting on GPI 1 can control the channel 2 volume from 0 to 100%
- GPI 1 at 75%: moving the FADER, it can control the channel 2 volume from 0 to 75%
- FADER at 75%: acting on GPI 1 can control the channel 2 volume from 0 to 75%
- etc.
- **PRESETS** (just available in GPI1): recall of one of the five presets in the DN44BOB memory, using the 5-position selector knob of a WPmVOL-SR / WPaVOL-SR or similar wall panel.
 - Selector position 0: preset 1 recall
 - Selector position 1: preset 2 recall
 - Selector position 2: preset 3 recall
 - Selector position 3: preset 4 recall
 - Selector position 4: preset 5 recall

A **GPO** port (General Purpose Output) is a relay with a common contact and two contacts: NO (Normally Open, with the relay at rest) and NC (normally closed, with the relay at rest). From the GPOs section it is possible to activate / deactivate the GPO ports of a DN44BOB unit by clicking on them. When you activate a GPO (clicking on it), contacts are reversed: contact closes for NO and opens for NC. Inactive contacts are filled in grey and active contacts light up in green:



In the picture the GPO 1, 3, and 4 are active and GPO2 is inactive

GPO status (active or inactive) can be stored in the Presets, so that recalling one of them also recalls the existing combination of active/inactive GPOs at the time of storage.

11.1.3. DN44BOB ANALOGUE AUDIO INPUTS section

The INPUTS section of a DN44BOB device has the following appearance:



The window shows the controls and indicators for the 4 analogue inputs that the unit can receive using its rear panel balanced terminals, and that will be converted to 4 Dante Channels:

- **IN n** label: can be clicked and edited (text field)
- **PHANTOM**: toggles the remote DC power supply for the condenser microphones connected to this physical input
- **Sensitivity**:
 - **0 dB**: LINE level signals
 - **-20 dB**: LOW LINE level signals, as delivered by MP3 players, iPod®, smartphones, laptops, etc.
 - **-40 dB**: MIC level signals
- **GAIN**: ± 10 dB adjustment of the incoming signal gain

- **VOLUME** (fader): input volume, adjustable between $-\infty$ and 0 dB. There are two Vu meter-type level indicators to the right of the channel fader: the left bar displays the input signal level (after the sensitivity and gain controls) and the right one the signal level after the VOLUME control. Above the bar, the saturation indicator (CLIP) lights up when the input signal exceeds the saturation level
- **MUTE**: mutes audio for this channel.
- **POLARITY**: allows the input signal phase to be inverted (180 degrees shift).

The above adjustments will define the audio level of each input, before being converted to a Dante channel and sent to the network through the RJ45 connector.

11.1.4. DN44BOB ANALOGUE AUDIO OUTPUTS section

The OUTPUTS section of a DN44BOB device has the following appearance:



It shows the controls and parameters for the 4 analogue audio outputs that the unit delivers at its 4 rear panel balanced audio output terminals, which take their contents from the 4 Dante channels received in the unit from the network, through the RJ45 connector:

- **OUT n** label: can be clicked and edited (text field)
- **GAIN**: 0 to +6 dB additional gain for the channel
- **VOLUME** (fader): output volume, adjustable between –infinite and 0 dB. There are two Vu meter-type level indicators to the right of the channel fader: the left bar displays the output signal level (after the gain control) and the right one the channel output signal level after the VOLUME control. Above the bar, the saturation indicator (CLIP) lights up when the input signal exceeds the saturation level
- **MUTE**: MUTE: mutes audio for this channel.
- **POLARITY**: allows the input signal phase to be inverted (180 degrees shift).

11.1.5. DN44BOB DANTE routing

EclerNet Manager can handle the DN44BOB controls and parameters for its analogue audio inputs and for its analogue audio outputs, but not where the input DANTE channels do come from (which Dante device and channel in the network) and where do the DANTE output channels are sent to (which Dante device and channel in the network), in other words, the DANTE routing. This task is done in DANTE compatible devices using Audinate's Dante Controller proprietary software, available from here: <https://www.audinate.com/products/software/dante-controller>

In the above link it can be found as well instructional information and tutorials to understand how to manage Dante Transmitter and receiver devices and channels.

The next image is a screenshot of Dante Controller app, where 2 DN44BOB units, called BOB4 and BOB5 are managing the next Dante routing:

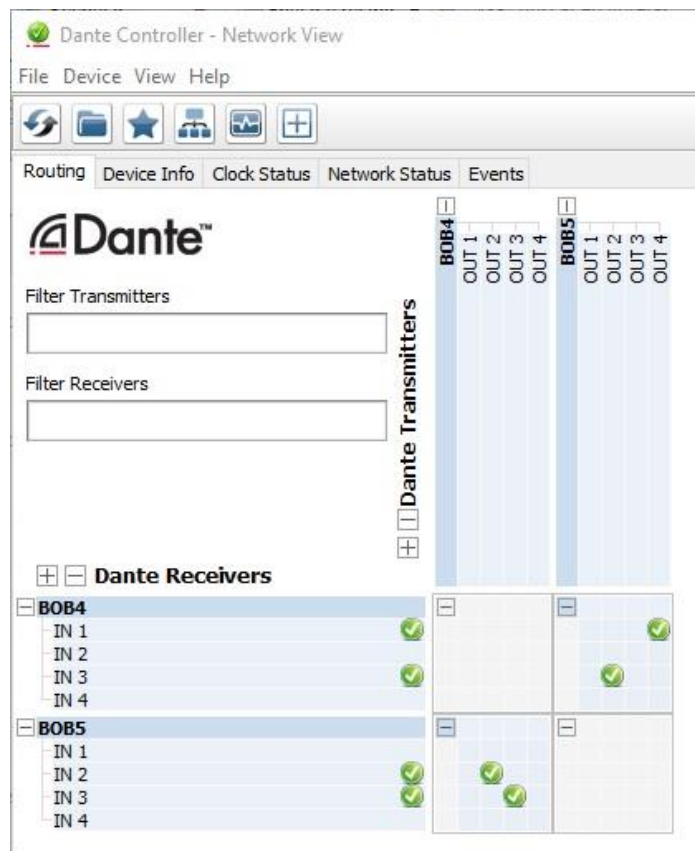

- BOB4 is sending its audio analogue signals to the Dante network:
 - IN1 is received by BOB5 and delivered at its OUT4 analogue output
 - IN3 is received by BOB5 and delivered at its OUT2 analogue output
- BOB5 is sending its audio analogue signals to the Dante network:
 - IN2 is received by BOB4 and delivered at its OUT2 analogue output
 - IN3 is received by BOB4 and delivered at its OUT3 analogue output

These are more screenshots from Dante Controller app, showing how Ecler DN44BOB units are seen there:

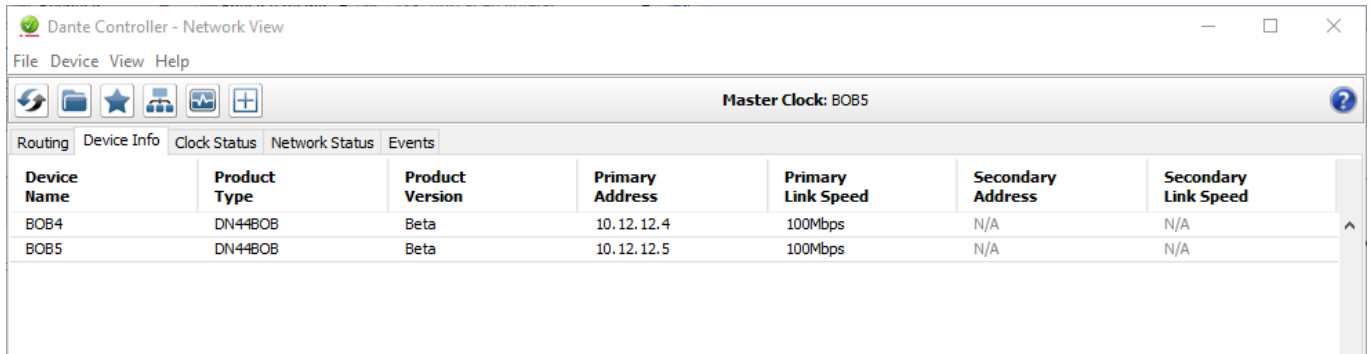

Dante Controller - Network View

Master Clock: BOB5

Device Name	Product Type	Product Version	Primary Address	Primary Link Speed	Secondary Address	Secondary Link Speed
BOB4	DN44BOB	Beta	10.12.12.4	100Mbps	N/A	N/A
BOB5	DN44BOB	Beta	10.12.12.5	100Mbps	N/A	N/A

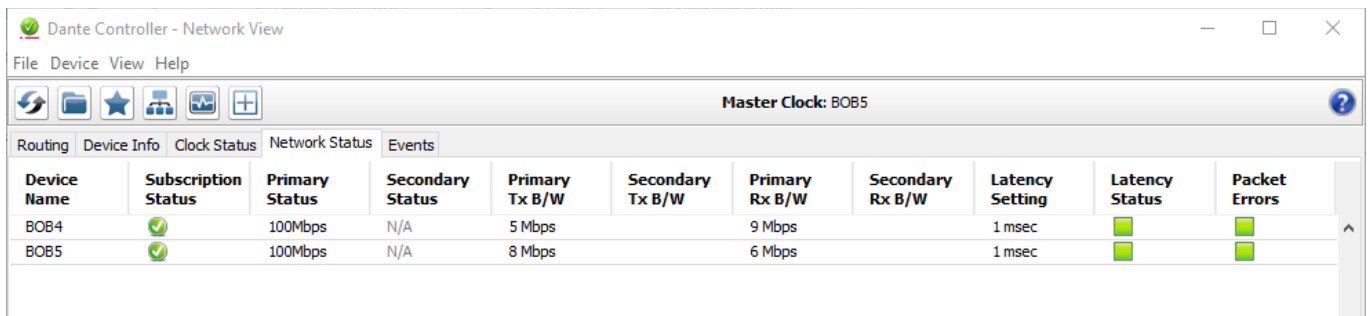

Dante Controller - Network View

Master Clock: BOB5

Device Name	Subscription Status	Primary Status	Secondary Status	Primary Tx B/W	Secondary Tx B/W	Primary Rx B/W	Secondary Rx B/W	Latency Setting	Latency Status	Packet Errors
BOB4	✓	100Mbps	N/A	5 Mbps		9 Mbps		1 msec	■	■
BOB5	✓	100Mbps	N/A	8 Mbps		6 Mbps		1 msec	■	■

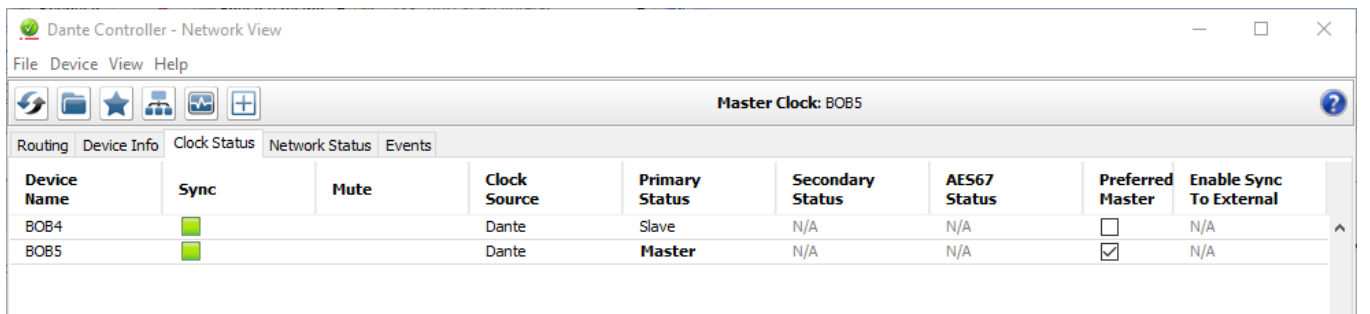

Dante Controller - Network View

Master Clock: BOB5

Device Name	Sync	Mute	Clock Source	Primary Status	Secondary Status	AES67 Status	Preferred Master	Enable Sync To External
BOB4	■		Dante	Slave	N/A	N/A	<input type="checkbox"/>	N/A
BOB5	■		Dante	Master	N/A	N/A	<input checked="" type="checkbox"/>	N/A

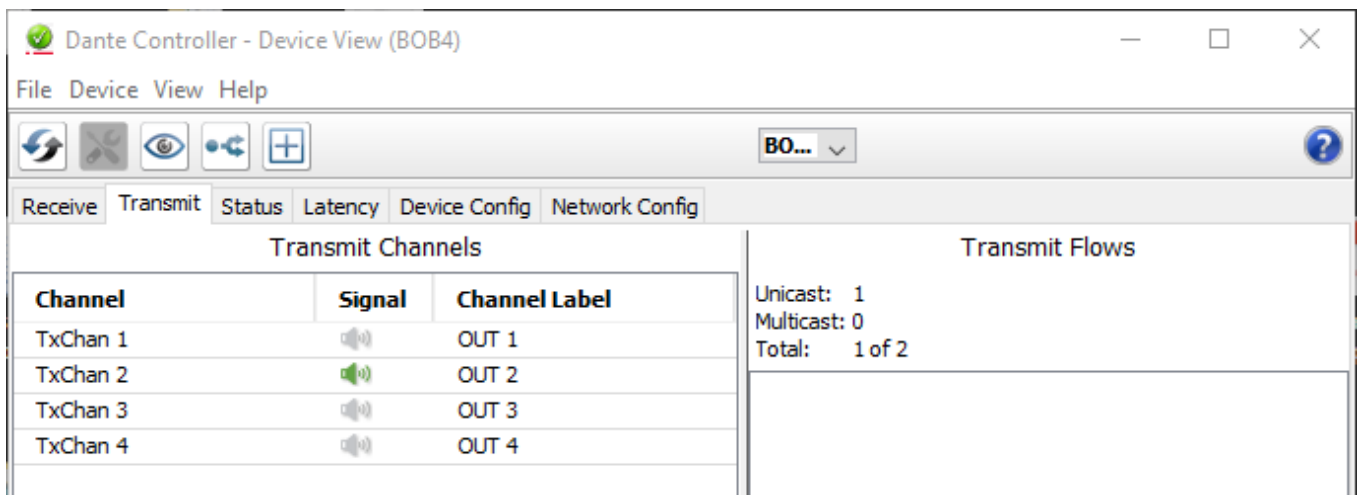

Dante Controller - Device View (BOB4)

BO...

Channel	Signal	Channel Label
TxChan 1	🔊	OUT 1
TxChan 2	🔊	OUT 2
TxChan 3	🔊	OUT 3
TxChan 4	🔊	OUT 4

Transmit Flows

Unicast: 1
Multicast: 0
Total: 1 of 2

Dante Controller - Device View (BOB4)

File Device View Help

Receive Transmit Status Latency Device Config Network Config

Receive Channels

Channel	Signal	Connected to	Status
IN 1		OUT 4@BOB5	
IN 2			
IN 3		OUT 2@BOB5	
IN 4			

Available Channels

- BOB4
- BOB5

Dante Controller - Device View (BOB4)

File Device View Help

Receive Transmit Status Latency Device Config Network Config

Device Information

Manufacturer: Ecler
 Product Type: DN44BOB
 Product Version: Beta
 Software Version: 1.0.0
 Firmware Version: 1.0.0

Dante Information

Model: Ultimo4
 Software Version: 2.2.3.5
 Firmware Version: 1.0.0.2

Clock Synchronisation

Mute Status: Unmuted
 Sync Status: Locked
 External Word Clock: No
 Preferred: No
 Frequency Offset: -6 ppm

Interfaces

P

IP Address: 10.12.12.4
 MAC Address: 00:1D:C1:0A:43:04
 Tx Utilisation: 5 Mbps Errors: 0
 Rx Utilisation: 9 Mbps Errors: 0

Clear Counters

12. EclerNet COMPATIBLE DEVICES: Video Over IP Extenders and Matrixes

12.1. VEO-XTI2L and VEO-XRI2L

12.1.1 Introduction

VEO-XTI2L and VEO-XRI2L are the first video devices controllable by the EclerNet environment. They allow to distribute 4K video signals on standard Ethernet Networks.



The main features are:

- 4K UHD HDMI over Ethernet distribution
- USB 2.0 over Ethernet distribution for KVM applications
- Supports optical fiber extension up to 60Km (Single Mode)
- Supports up to 3840X2160@60hz YUV 4:2:0 input and 3840X2160@30hz outputs
- HDCP 2.2 / HDCP1.4 compliant
- Supports bi-directional Wide Band IR (38KHZ-56KHZ) pass-through
- Supports RS-232 pass-through and Telnet control
- Includes IR remote/front panel control of Group ID channel, with LED display to show the Group ID in use
- SPDIF 5.1 and L/R analogue stereo embedding and de-embedding
- Video wall composition (Max 8x8)
- Supports PoE (Power over Ethernet) or external 5V-18V power supply
- UCP panels compatible

From firmware version 2.00r0 onwards, the VEO-XTI2L and VEO-XRI2L devices are compatible with EclerNet. This means that, if connected to the same network, they can be discovered by the

software. Please refer to “VEO-XTI2L and VEO-XRI2L upgrade manual” for more information about the firmware upgrade.

12.1.2. Device discovery

The devices, by factory default, will come in auto-ip mode, in order to facilitate the change of address in the desired range. In this way it will be possible to connect all the devices to the network and subsequently change all the IPs, without having to do it one at a time.

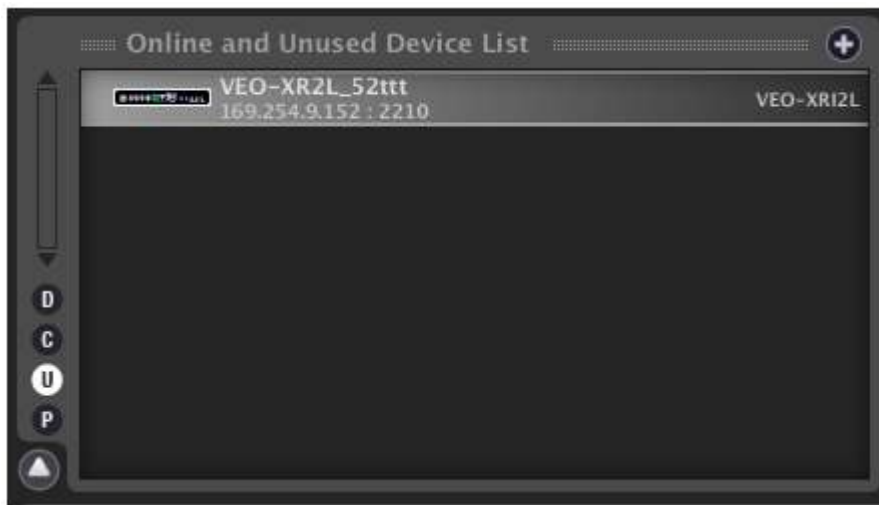

Once discovered, it will be possible to change the IP address of the devices, using the Network Configuration menus:

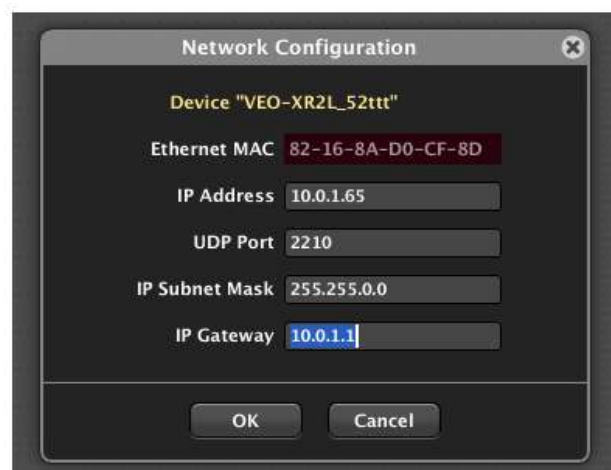

This operation will automatically reboot the devices, assigning the new IP address; the devices can be added to an EclerNet Project as explained on chapter 8.

12.1.3. VEO-XTI2L Settings

Once that a VEO-XTI2L transmitter is included in a EclerNet Project, using right button of the mouse it is possible to rename it with a friendly name, for example the same of the source where it is connected.

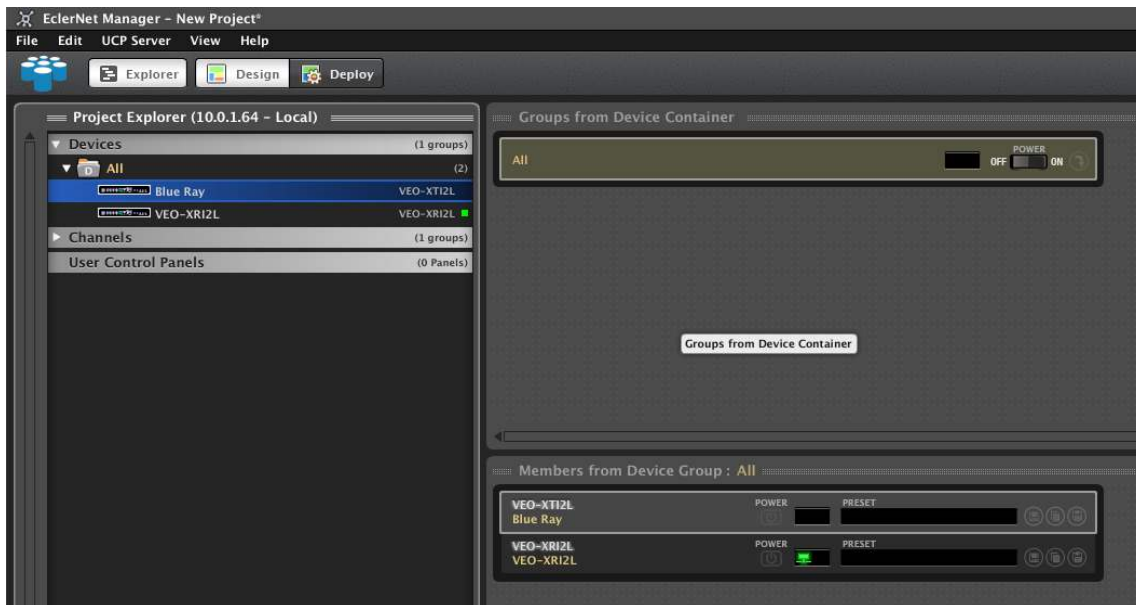

The device will appear in the Member from Device Group window and, double clicking on it, it will be possible to enter to the configuration menu.

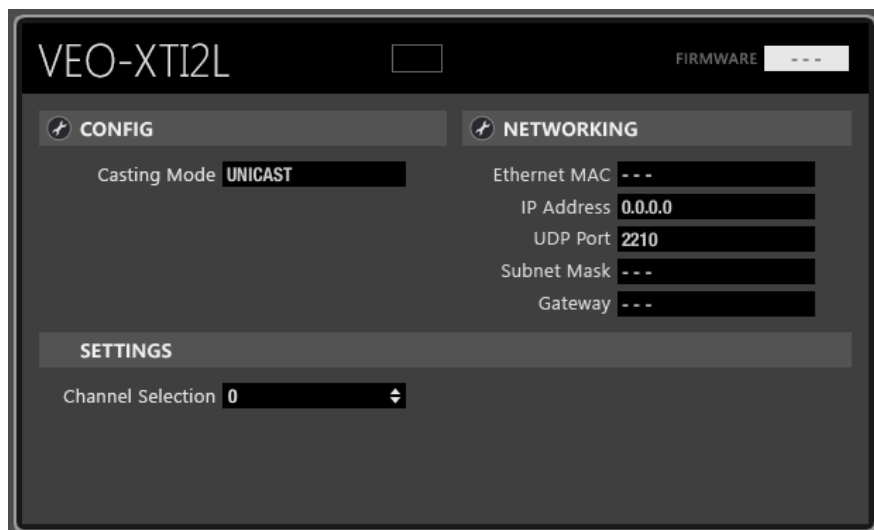

12.1.3.1 CONFIG Menu

Using the configuration menu, it is possible to select the unicast or multicast mode:

- **Unicast:** used for point-to-point extensions. The video stream encoded by the transmitter is sent like unicast network stream and it can be received only by one receiver at time.
- **Multicast:** used for point-to-multipoint and matrix extensions. The video stream encoded by the transmitter is sent like multicast traffic using a predefined multicast address. In this way all the receivers “tuned” on that address, are able to receive the video signal.



12.1.3.2. SETTINGS Menu

Using this menu, it will be possible to set the transmission channel for each VEO-XTI2L transmitter.

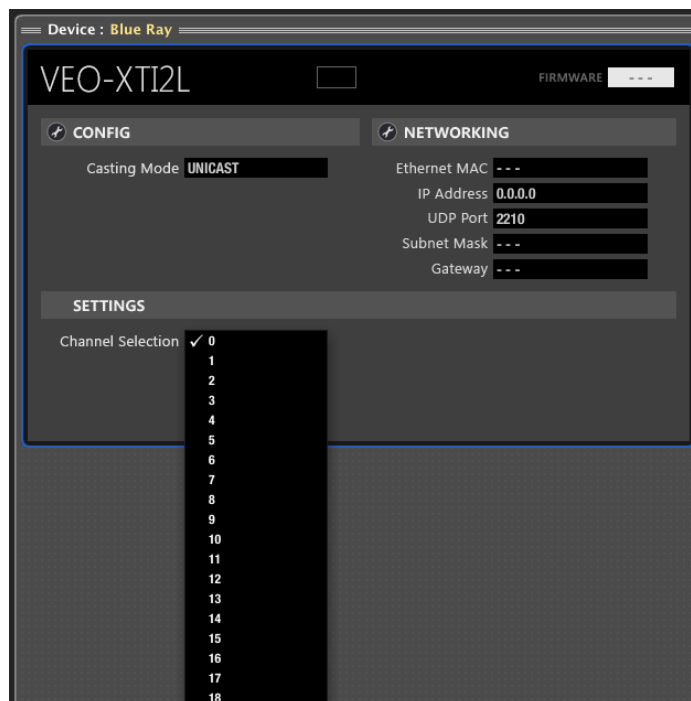

Note: Each VEO-XTI2L transmitter must be settled with a unique channel number in the same network. If two transmitters are transmitting on the same channel they will create network conflicts.

The channel number will appear on the hardware unit front display and will identify each device.

12.1.4. VEO-XRI2L Settings

Once that a VEO-XRI2L transmitter is included in a EclerNet Project, using right button of the mouse it is possible to rename it with a friendly name, for example the same of the zone where it is placed.

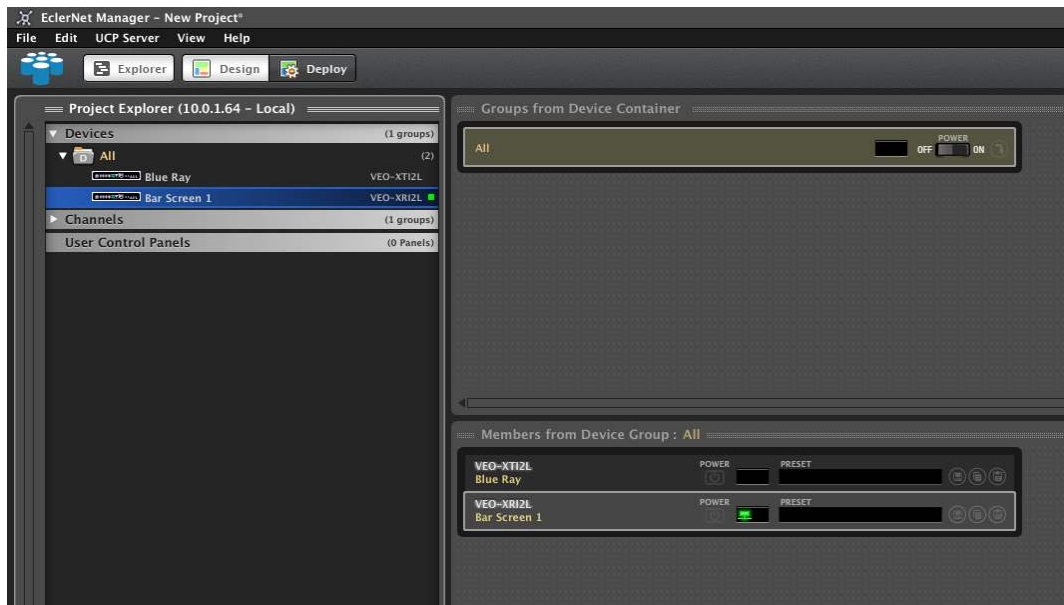

Through the Device Finder functionality, it will be possible to identify each receiver on the installation.

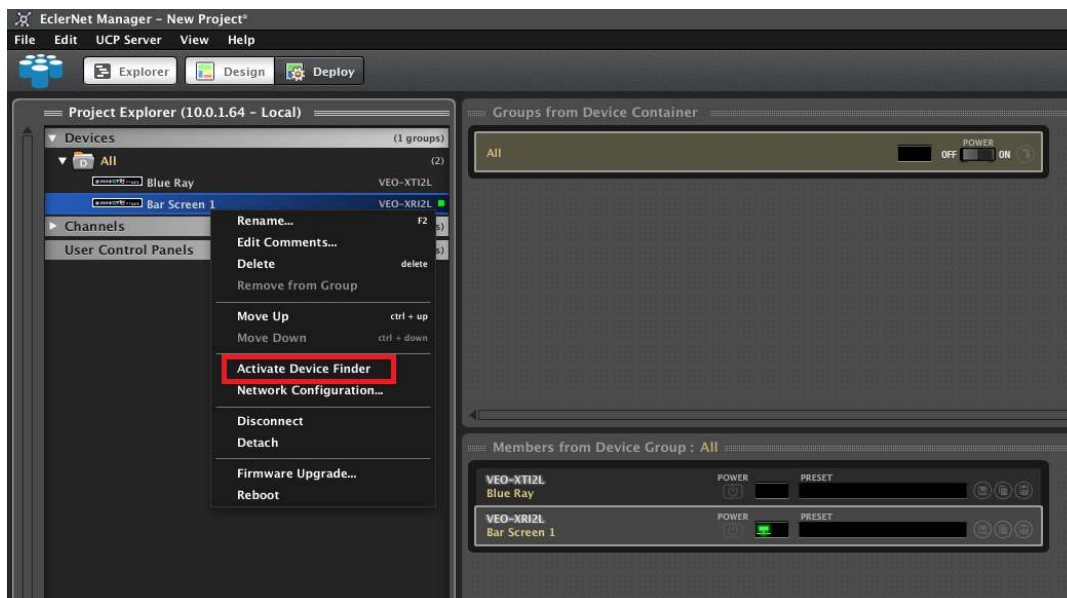

Once that the functionality is enabled, the name of the device and the related IP address will appear on the display monitor or screen connected to each VEO-XRI2L receiver.

Note: The Device Finder doesn't work properly in Videowall mode due to the image scaling.

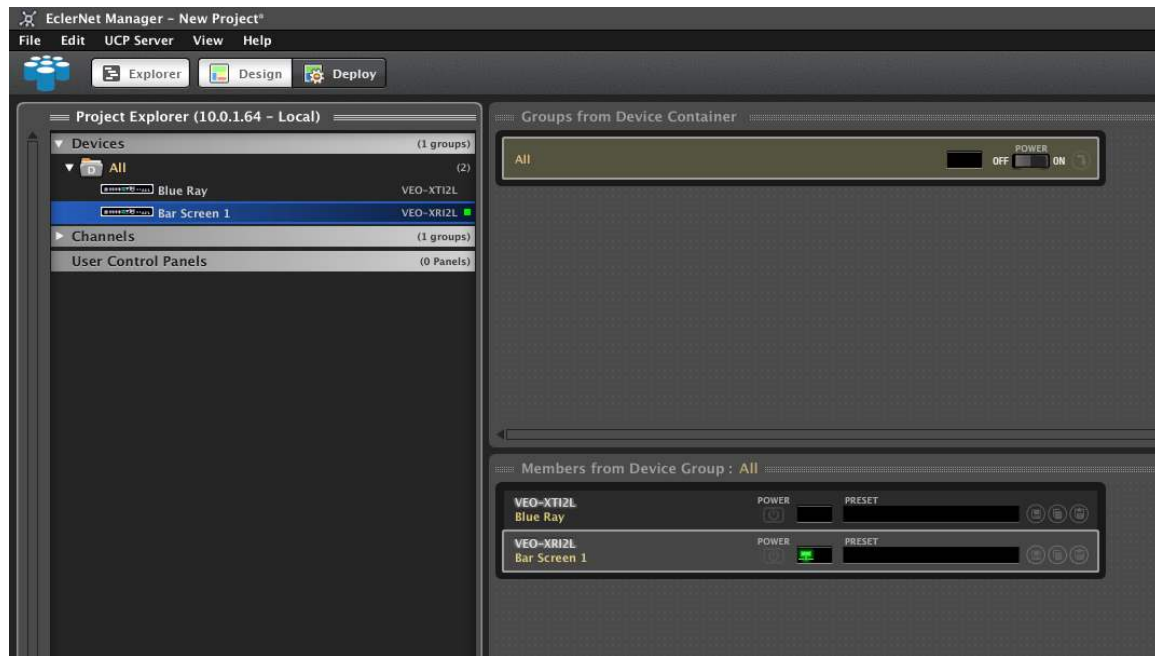

After the EclerNet Project inclusion, the device will appear in the Member from Device Group window and, double clicking on it, it will be possible to enter to the configuration menu.

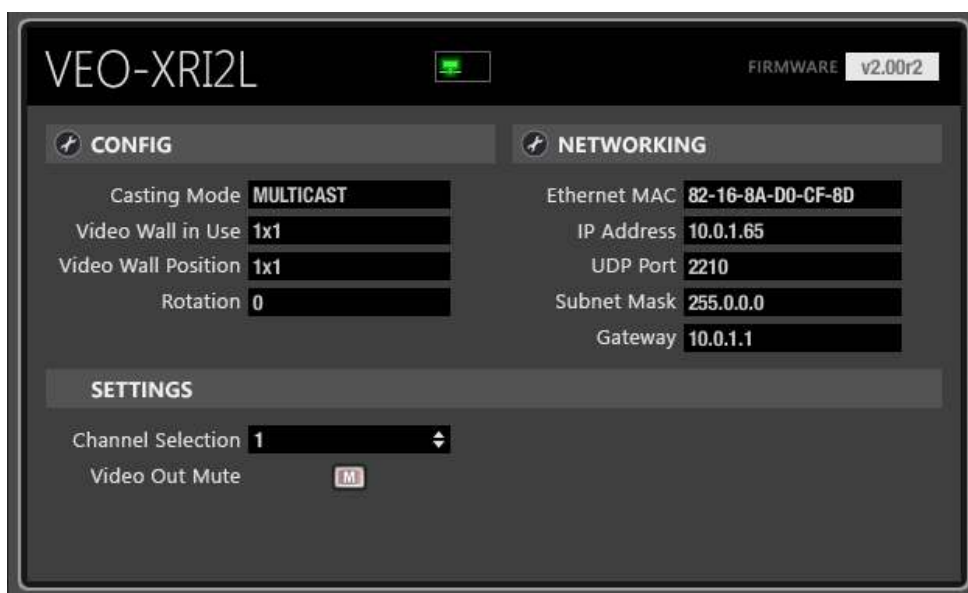

12.1.4.1. CONFIG Menu

Using the configuration menu, it is possible to set many different parameters.

The first one is the unicast or multicast mode:

- **Unicast:** used for point-to-point extensions. The video stream encoded by the transmitter is sent like unicast network stream and it can be received only by one receiver at time.
- **Multicast:** used for point-to-multipoint and matrix extensions. The video stream encoded by the transmitter is sent like multicast traffic using a predefined multicast address. In this way all the receivers “tuned” on that address, are able to receive the video signal.

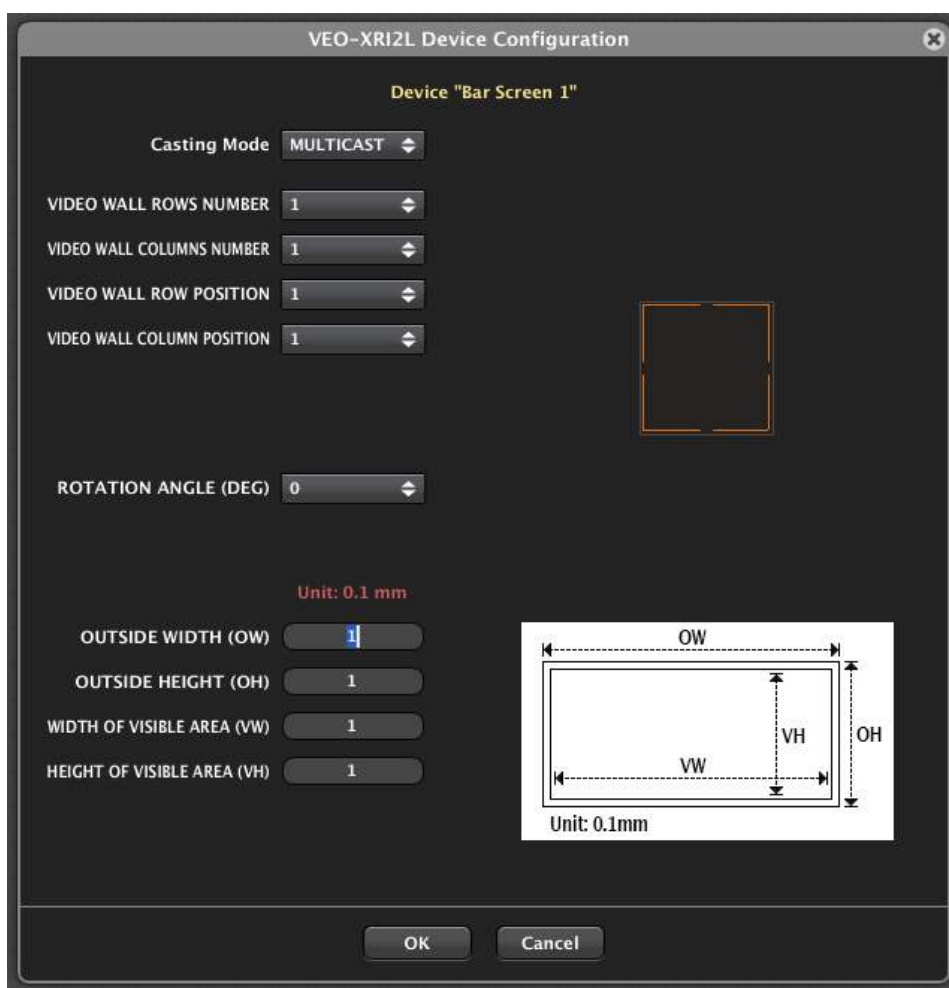

Using the same menu, it will be possible to easily create a video wall.

Video wall rows and columns number define the size of the video wall and must be common to all the receivers forming the screen.

Video wall row and column position will define the position of each receiver in the screen. These parameters will be different for each device.

A dynamic image will appear on the right of the window parameters in order to help identifying the selected position.

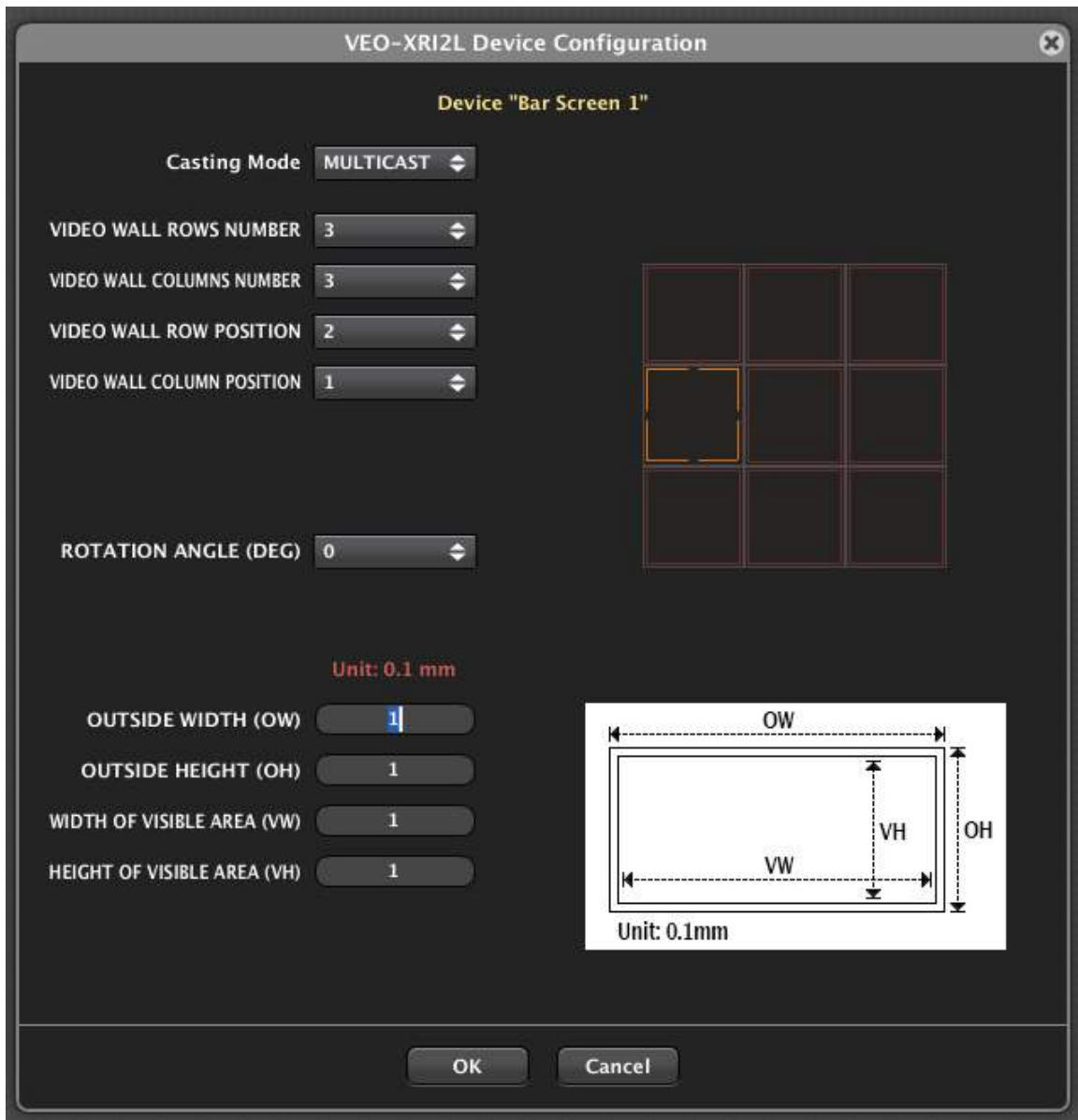

The configuration menu allows also rotating the image by 90, 180 or 270 degrees;

The bottom parameters allow setting the bezel compensation when required. Defining total screen dimensions and size of visible area, the engine will automatically crop the image calculating the lost area of the image.

12.1.4.2 SETTINGS Menu

Using this menu, it will be possible to set the channel to display on each VEO-XRI2L device and enable/disable the HDMI output through the mute function.

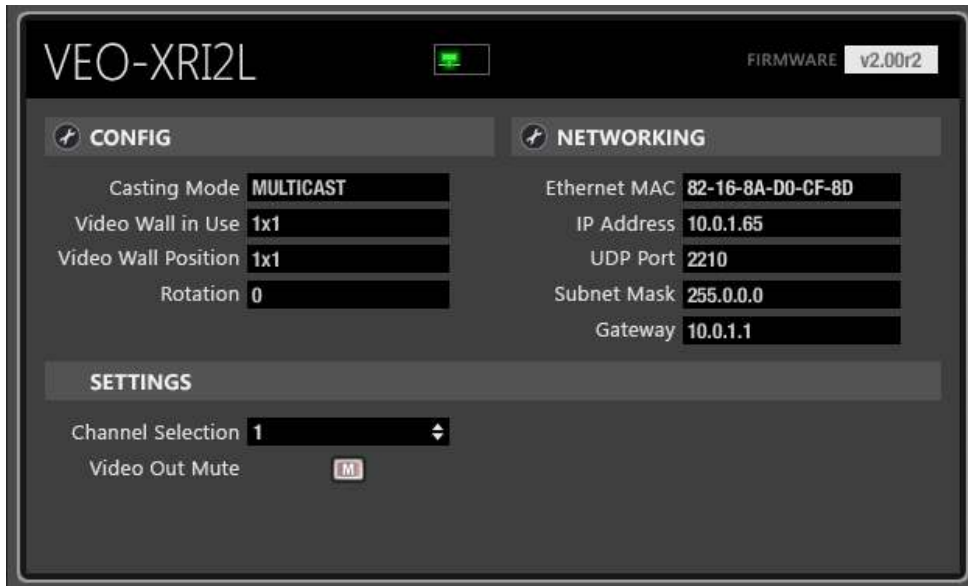

Note: If the selected channel doesn't correspond to an active VEO-XTI2L streaming channel, the refresh time will take up to 10-15 seconds.

12.1.5. UCP control features

EclerNet manager allows easily creating graphic user interfaces through UCP panels.

In this case it will be possible to easily create source selection and matrixes for the control of the VEO-XRI2L receivers. VEO-XTI2L transmitters don't require this kind of control because the transmitting channel is unique and fixed, and it must be set during the installation commissioning.

Once a new panel and a new page are created, buttons, multi-buttons, or rotary controls can be used to create customized graphic interfaces.

The next example shows how to create a simple 3x3 matrix:

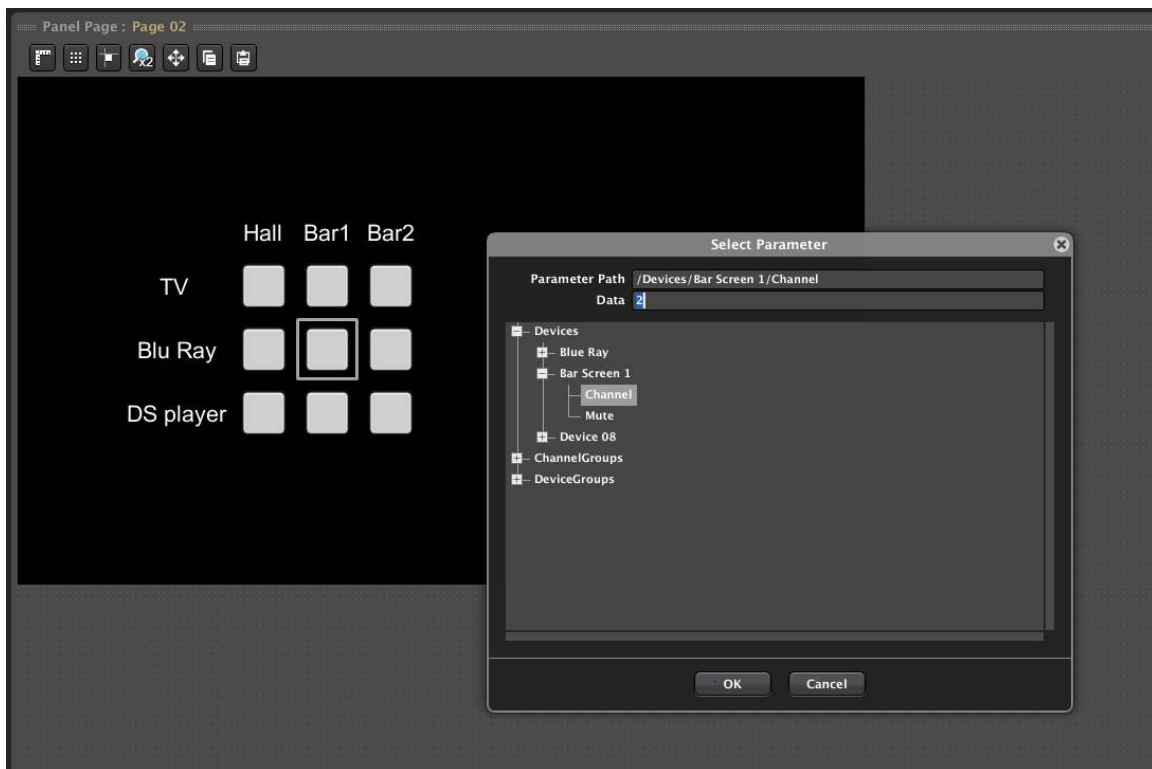

Each column represents a VEO-XRI2L receiver and each row represents a source identified by its related VEO-XTI2L transmission channel.

Each button allows selecting a defined channel through the Select Parameter window. In this way it is possible to create matrixes with a flexible number of inputs and outputs.

The button will be lit if the corresponding channel is selected: in this way, a quick feedback of the status of the matrix is available.

13. USER CONTROL PANELS (U.C.P.)

13.1. Introduction

From EclerNet Manager application itself, you can create remote control panels for the system (hereinafter **UCPs**) to manage one or more MIMO88, MIMO88SG, MIMO1212SG, MIMO4040CDN, MIMO7272DN, NXA, NPA, DUO-NET or other EclerNet units in a facility. Each panel can consist of one or more pages that include graphics, text, volume controls, buttons, VU meters, LED indicators, etc. In this way each remote user may have his own control panel(s), custom tailored to his needs and privileges, and in one system, users with a very simple control panel can coexist with others, more complex and having higher levels of authorization.

A panel can be public (anyone can use it) or associated with one or more user accounts created in the project. In this last case, it requires a user name and a password to remotely access and operates it.

UCPs are created within an EclerNet project and stored as part of it, within the **User Control Panels** folder in the Project Explorer window:



Once UCPs are created, a UCP web server device is required, running the EclerNet Manager application and the project containing the UCPs, and UCPs can be called and operated remotely by devices that act as UCP web clients.

UCP servers can be Ecler WPNETTOUCH, PAGENETDN, WPmSCREEN or MIMO4040DN units, or even computers running an EclerNet project in Deploy mode.

UCP clients can be computers or tablets running an Internet browser application (Internet Explorer, Google Chrome, Mozilla Firefox, etc..), Android OS devices (tablets, smartphones), Apple devices (iPhone, iPad, etc..) or WPmSCREEN / WPNETTOUCH units. Any of them can recover and operate UCPs pointing to the web server IP address. A WPNETTOUCH / WPmSCREEN / PAGENETDN device can even be itself a server and a client at the same time (see WPNETTOUCH section for more details).

If a single computer acts as both a web server and a web client, it's still possible to use the 127.0.0.1 IP address, or the standard loopback address (or even typing directly **localhost**) to operate UCPs stored in the project EclerNet Manager it is running. You can even run EclerNet Manager in minimized and protected mode so that the system user sees and manages UCPs, but can't access EclerNet Manager, when a single computer acts as web server and web client.



Different web clients can simultaneously load different UCPs and operate the project at the same time, each one controlling a part of the system.

13.2. Creating UCPs

Important: Before initiating any UCP creation or editing operation on existing UCPs, please ensure that EclerNet Manager is in Design mode, not in Deploy mode. Deploy mode should be used later with UCPs that are already created when you want to enable the EclerNet Manager web server mode and its management from web clients.

To create a new UCP, you must open the context menu (right mouse button) on the **User Control Panels** folder in the Project Explorer window and select **Add Panel**.



Each UCP must have at least one page including the desired user controls:

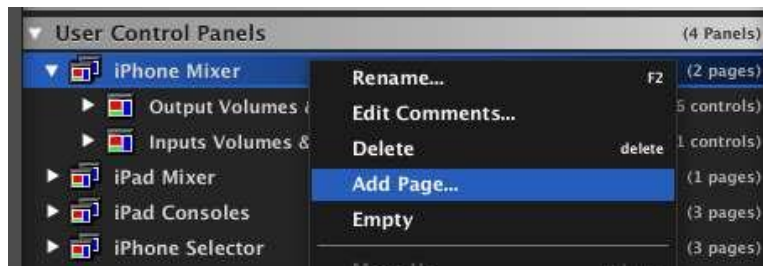

In the example, two pages ("Output Volumes" and "Inputs Volumes") are included in the UCP called "iPhone Mixer"

If a panel has more than one page, you can scroll the pages from a remote device (web client) using the cursor arrows that appear when you double click on an empty space of the screen or by clicking and dragging horizontally on the screen ("drag & drop") with the mouse, or with your finger on a touch screen if the device has one (iPhone, iPad, tablet, etc..).



Double-clicking on a empty space of the screen shows the left and right arrow keys and the X symbol which is used to return to the root display of the available project panels (same function as the ESC key)



This sequence shows a shift from "Output channels" page to "Input channels" page.

Clicking on the Properties icon in the Project Explorer helper window, you can see and manage the general properties of the panels and pages inside panels, like its size (in pixels), the users that will be allowed to access them, the optional default page in a panel (the one that will be shown on screen after more than one minute with no user interaction) colour of the pages background, etc.:

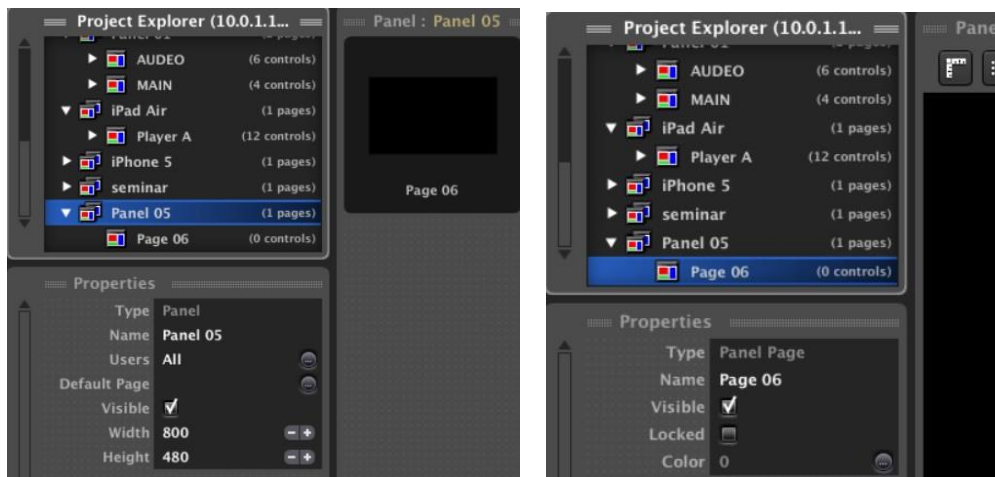

To add a control in a page, click with the right mouse button and select the type of control to add from the drop-down list:

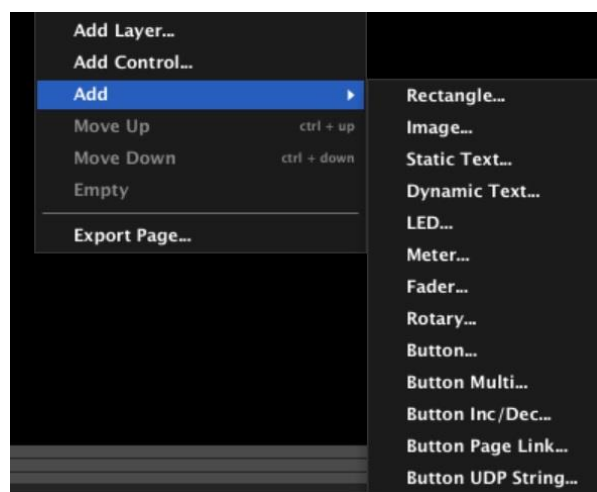

This is a summary of the available types of controls:

- **Rectangle:** rectangular graphic that can be tailored (colours, transparency, border width, etc.), useful to create separated control areas in a screen, etc.
- **Image:** allows to insert a jpg, png or bmp image in the UCP screen
- **Static Text:** a text which will be always fixed, with no update coming from parameters or values in the current UCP project
- **Dynamic Text:** a text field that will show in real time the text or numeric value of its associated parameter (media tags in DUO-NET player, volumes, MUTE status, vumeters reading, virtual controls values, active preset number or name, etc.) as the system is in use
- **LED:** LED indicator, that can be linked to parameters with a digital profile (as MUTE controls, for instance), showing its ON / OFF status
- **Meter:** mainly intended to be used as a vumeter, linked with volume meters at inputs, outputs, matrix cross points, etc.
- **Fader:** sliding type volume control
- **Rotary:** rotary type volume control
- **Button:** a key that can be pressed to trigger actions (preset recall, MUTE function, PLAY / STOP in a DUO-NET PLAYER, etc.)
- **Button MULTI:** a key that triggers a batch of actions with a single press
- **Button INC/DEC:** allows to link it to parameters that can be adjusted in positive (INC) or negative (DEC) quanta (**Amount** parameter can be positive or negative), each time it's pressed. Example: a button to increment a given VOLUME and another one to decrement it, with a configurable increment / decrement amount for those buttons' single press
- **Button PAGE LINK:** when pressed, it directly opens up a pre-defined panel page within the UCP panel
- **Button NET STRING:** (**new feature, from ENM v4.05r1**) when pressed, it sends a defined **UDP or TCP** text string, or a list (batch) of text strings to the defined IP:port. This is a very powerful tool to control external (even third-party) devices from a UCP panel, being able to build an integrated and single control system in an installation, including the management of audio, lighting, video, etc.

The EclerNet Manager Control possibilities through the UCP (User Control Panels) are now infinite: Total management of any device(s) in the same network at the same time by using UDP/TCP commands. Create small control routine for different type of devices: combine audio, lights, video, facilities automation, relays activation, etc. Just with one button!

The format in which the “NET String” has to be written is: `|protocol|address|port|text|`

Where:

- **-Protocol:** could be “UDP” or “TCP” (no sensitive between capital or lower-case letters)
- **-Address:** destination IP address
- **-Port:** destination port
- **-Text:** command message to be sent, including parameters (like \d, \n, etc.)

Example:

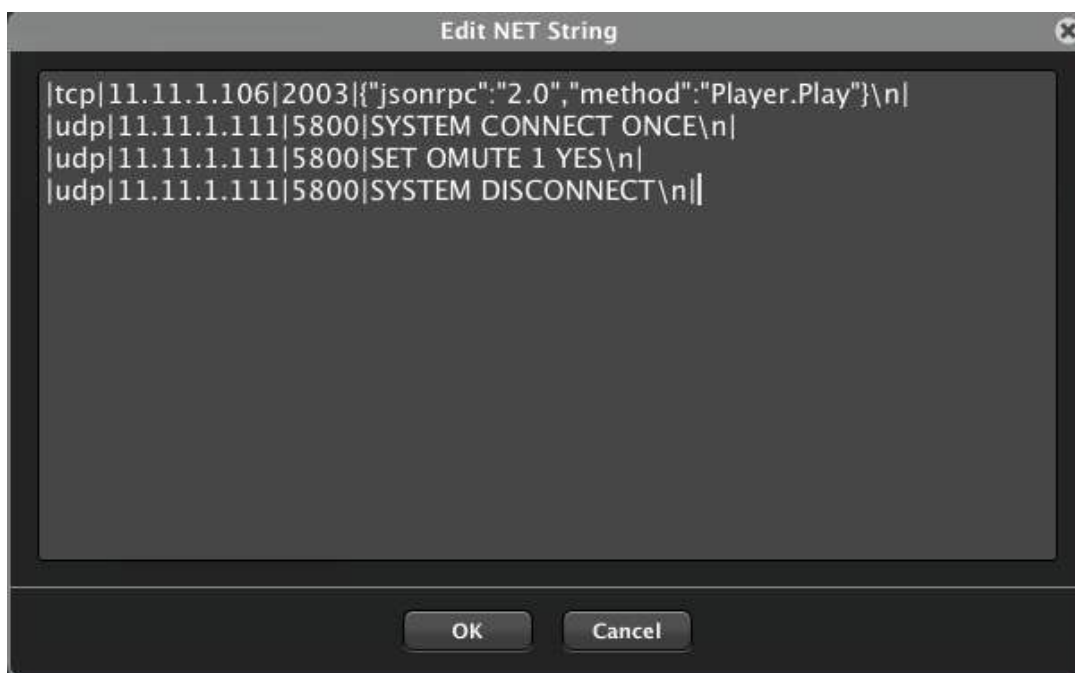

It is possible to send more than just one text string to different destinations. To do so, repeat the above specified format text the times needed. Now it's possible to add carriage return (multiline text field) to visually differentiate the different messages to be sent.

If you want to add the carriage return character to the text field which is going to be sent, you must introduce the character sequence “\r”, or “\n” to generate a line feed.

Examples:

ePLAYER1 PLAY/PAUSE Control

```
|tcp|11.11.1.106|2003|{"jsonrpc":"2.0","method":"Player.Play"}\n|
```

Script Execution using ePLAYER1 (previously configuring the script, ON PRESET- check out the ePLAYER1 manual-)

```
|tcp|11.11.1.106|2003|{"jsonrpc":"2.0","method":"Player.Open","Preset":6}\n|
```

Activate eMIMO1616 MUTE function:

```
|udp|11.11.1.111|5800|SYSTEM CONNECT ONCE\n|
```

```
|udp|11.11.1.111|5800|SET OMUTE 1 YES\n|
```

```
|udp|11.11.1.111|5800|SYSTEM DISCONNECT\n|
```

Also valid:

```
|udp|11.11.1.111|5800|
```

```
SYSTEM CONNECT\n|
```

```
SET OMUTE 1 YES\n|
```

```
SYSTEM DISCONNECT\n|
```

The list of the available additional parameters / commands for the text field is:

- **\dN** or **\DN** - delay time added
- **\d1** = **\D1** - 100ms delay
- **\d9** = **\D9** - 900ms delay
- **\d9\d6** - 1500ms delay

- **\xHH** = **\XHH** - for sending commands in hex (HH means 2 hex characters supported, after each \x parameter)
- **\x20** - space

- **** - \
-

- **\r** - 0x0D = cr - (carriage return)
- **\n** - 0x0A = lf - (line feed)
- **\0** - 0x00

Example to control third-party devices that request for user and password for the connection, using NET STRING keys in a UCP panel, and making use of delay parameters:

```
|tcp|192.168.1.20|24|\d2user\n
\d1password\n
\d1e e_vw_refresh_pos_idx_0_0\n
\d1e e_reconnect::0001\n
\d1e e_vw_enable_2_2_0_0\n\d2|
```

And the next example shows a connection to Ecler VEO series video device VEO-XRI2L model, selecting channel 1 for reception. It requires **root** as the login word, and no password after that:

```
|tcp|192.168.1.20|24|\d2root\n
\d1e e_reconnect::0001\n
```

From version v6 onward, a new feature has been introduced regarding the NET String buttons.

A new category of devices called EXTERNAL has been added in the ENM devices list like follows:



The Device Name can be customized and it can be used in the NET STRING button command strings: instead of specifying a fixed destination IP address, an alias name like, for example, "GENERIC_DEVICE" can be introduced in the command line,

NOTE: The Device Name of an EXTERNAL device CAN'T start with a number.

An example follows:

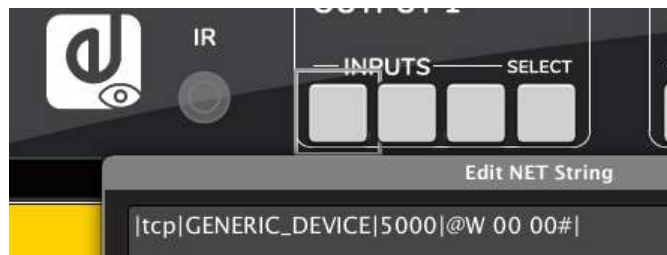

The IP address can then be changed later using the EXTERNAL device network settings.

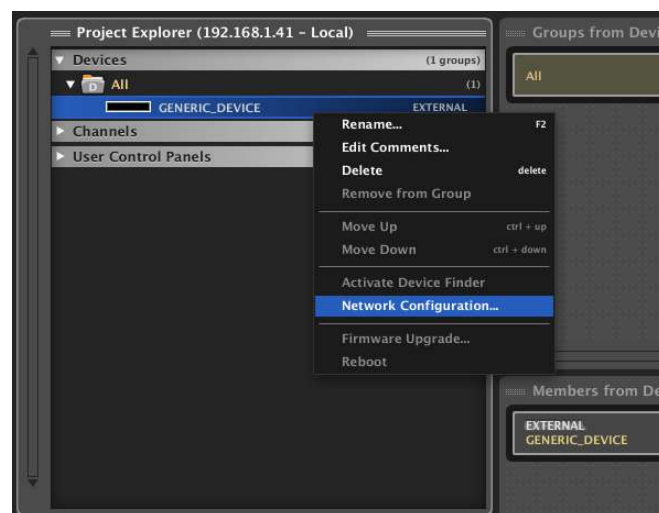

In this way it is possible to create generic UCP panels and easily assign an IP address to all the NET String buttons at once, without modifying all the command strings in the panel, one by one. Customers can then use generic UCP panels including NET String buttons to control this kind of External devices, and just edit their IP addresses, pointing to the real hardware in use in their projects.

The UCP graphical control will be inserted in the page with a "standard" look, as in this example of volume slider or standard fader:

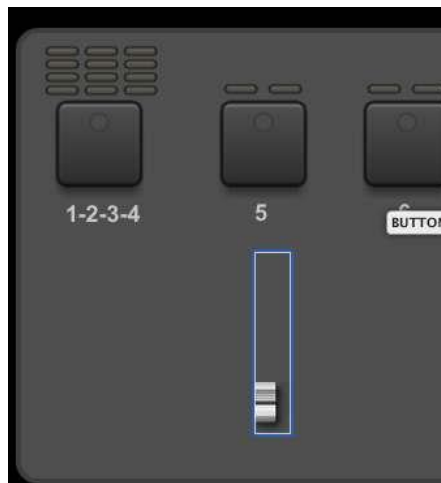

Note: you can use **Layers** as a tool to easily create a portion of a control screen and quickly "copy & paste" it as a new layer, then editing the parameters of the pasted layers individually. For instance, you can include in a layer a fader, a vumeter, a scale graphic and a MUTE buttons: copying, pasting and editing each individual copy, you can create a mixing control type control screen.

In the next picture, we can see that controls under CH1 page have been copied and pasted as a new layer within the same page, that then is shifted horizontally, and its controls are edited to point to the desired parameters. Repeating several times this process can make the panel become a mixing console type screen.

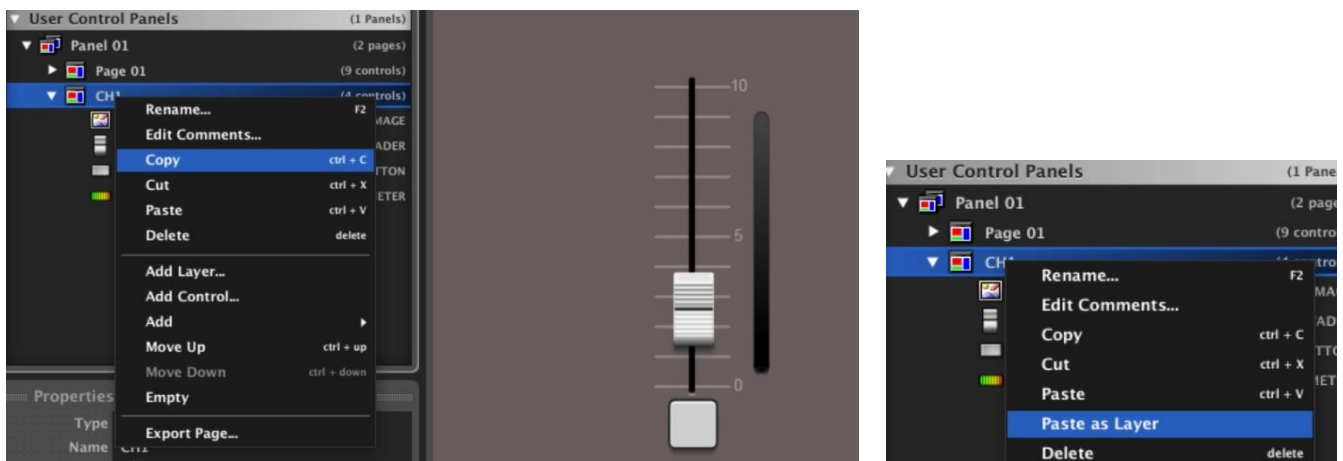

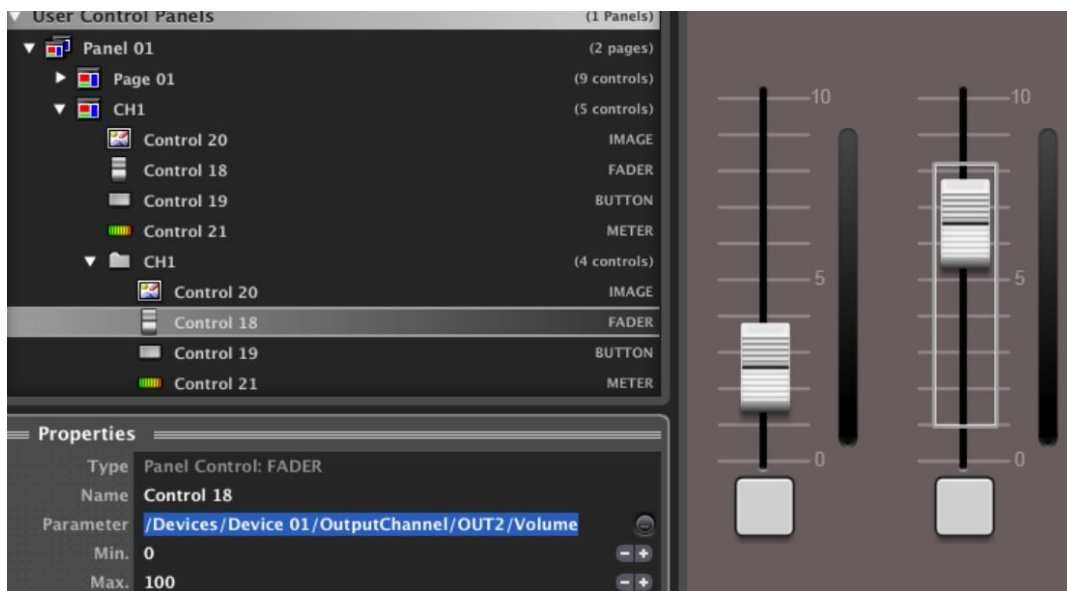
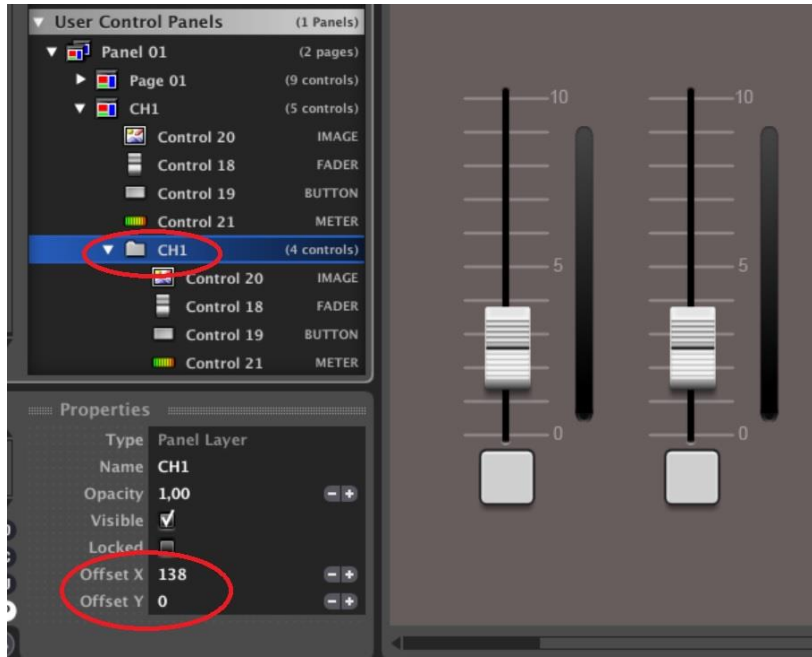

It's possible as well to use cut, copy and paste commands with panels, pages, layer and individual controls to make UCPs edition more straightforward, and even export pages or full panels to a file that can be later imported into a project, and edited according the project's specific needs:

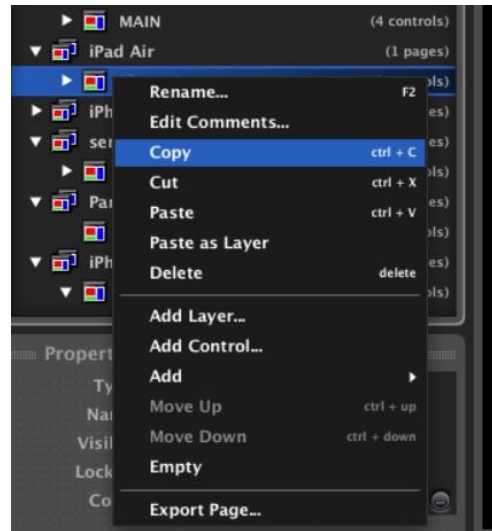

Once a control is added, you can modify any of its functional and graphic properties, as the minimum and maximum values its performance range can reach (minimum and maximum volume values for a fader or rotary knob), make it visible or hidden, give him a fixed position on screen ("locked"), select the course of its steps (the available course when the fader is raised or lowered, etc.).

Click on the P round icon in the Project Explorer Helper (the window located under the Project Explorer) to display a control's properties.

One of these properties is the visual aspect that you choose for each control. You can replace its "standard" look with one of those available in the library that is installed by default with EclerNet Manager (by clicking **File** and selecting the **controls library** folder):

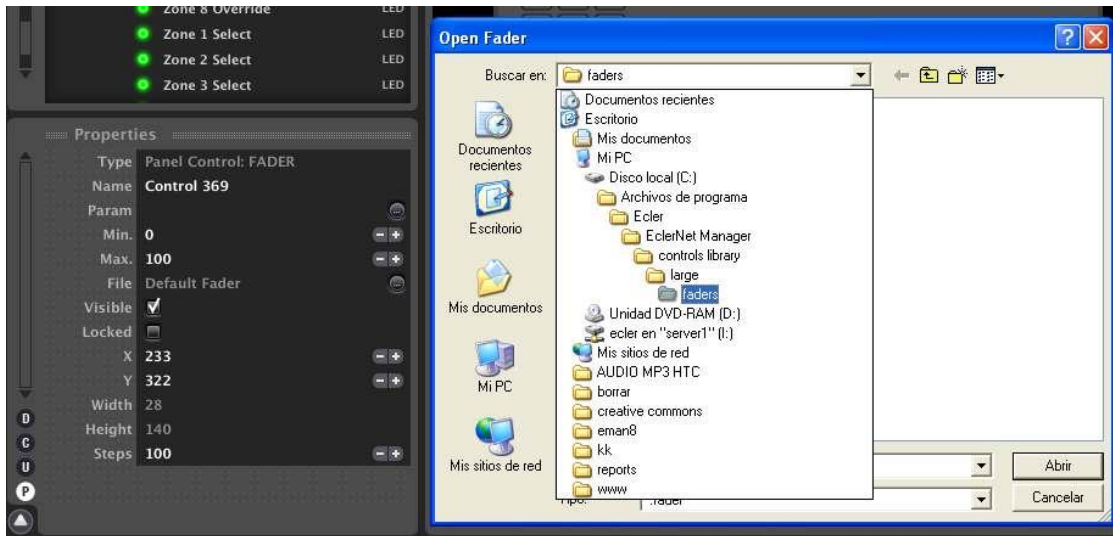

In this example, the standard look of a fader is replaced with a white larger one:

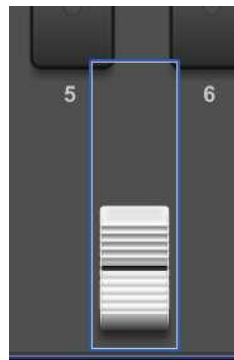

From v6 onwards, an interesting new feature has been added to the UCP panels to further expand the EclerNet control options.

From this version in fact, it is possible to graphically overlap several buttons of the same or different types (button, Inc / Dec, multi, page link and net string) so that they can be activated with a single press on the screen: many actions, even with different profiles (e.g.: MUTE, PAGE LINK, PRESET RECALL, etc.) can be triggered with a single button click.

The sensitive area will be that of the most superficial button (the one visible on top of the rest, stacked ones) but it will allow you to activate all buttons in the lower levels, simultaneously.

A new Opacity parameter has been added in the button visual aspect proprieties in order to make a button invisible if required.

In this way it is possible to combine different actions such as a button and a page link button, to create dynamic control surfaces.

There's even a dedicated subfolder in the library one (C:\Program Files (x86)\Ecler\EclerNet Manager\controls library\large\transport_control), which includes transport control icons for the buttons that may control the transport functions of a DUO-NET player in a UCP panel. Examples:



13.3. Functions assignment in the UCP

When controls are placed on the surface of the page, you need to assign them a parameter and a hardware unit to remotely control. To do this, select one of the controls and in the properties window click on the **Param** property:

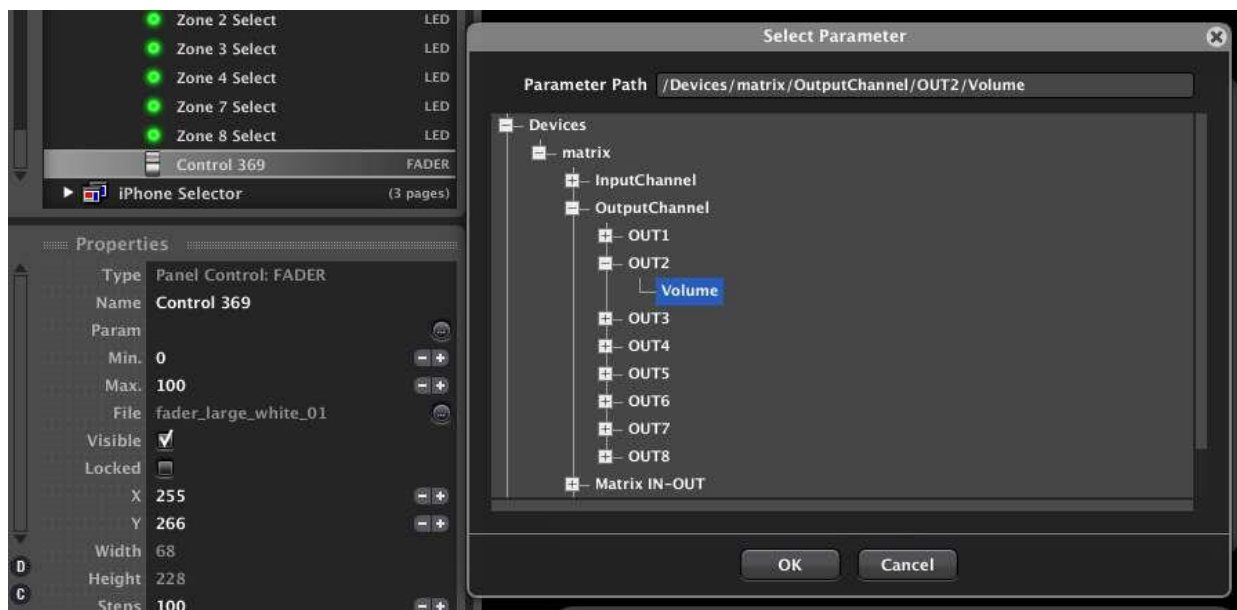

Then a browser window (Select Parameter) opens to select a hardware unit of the project and, within it, a parameter to control. Continuing the example above, the fader that is now displayed with its new appearance (large, white) will control OUT2 volume in a device called "matrix" (in this case a MIMO88).

Selectable hardware devices are all MIMO88s, NXAs, NPAs, DUO-NET or other EclerNet hardware devices that were previously included in the project. Thus, a single UCP can have a global control over all hardware devices of the installation (inputs volume and mute, outputs and/or groups of inputs or outputs, presets recall, sending messages to destination areas, etc.), so that the user

manages the installation as a single global entity from a single control panel, without taking care of the number, the location and the connection of hardware units that are really working behind it.

In the following example we see a project that includes 5 MIMO88 units, called **matrix**, **Lecture th. #1**, **Lecture th. #2**, **EVAC SYSTEM** and **OUTDOOR areas**, that might have some of their parameters linked to virtual controls in our UCPs:



In this case, for example, we could create an UCP with a page that contains multiple faders arranged side by side, as in a live mixer, and assign these faders to control inputs/outputs volumes in the MIMO88 units. The remote user can consider and use the system as a single large mixer or audio matrix, when 5 MIMO88 units are in fact working, not a single large matrix hardware.

When you select a control and click on **Param** property to set its function in the project, the window displays only the parameters that are compatible with this control. For example, the options for a button will be mute, presets recall, paging function, etc., but there's no volume option as a standard button can only have ON or OFF values (100 or 0), not all the range of values between 0 and 100 that a volume control needs.

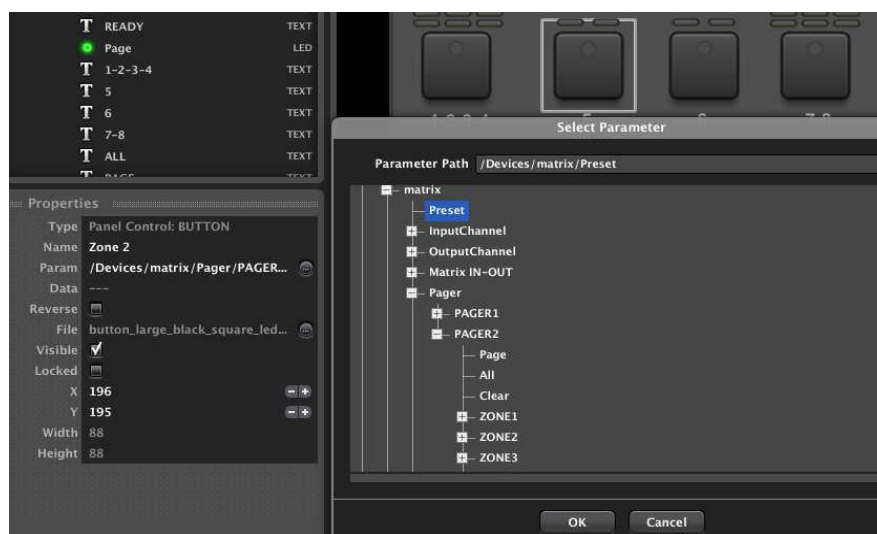

Once a parameter is assigned to a control, you can even directly edit the text that defines it, just typing in the modifications. In this example, we modify a parameter that points to the volume of OUT3 in a MIMO88 unit to point to the VOLUME of OUT7:

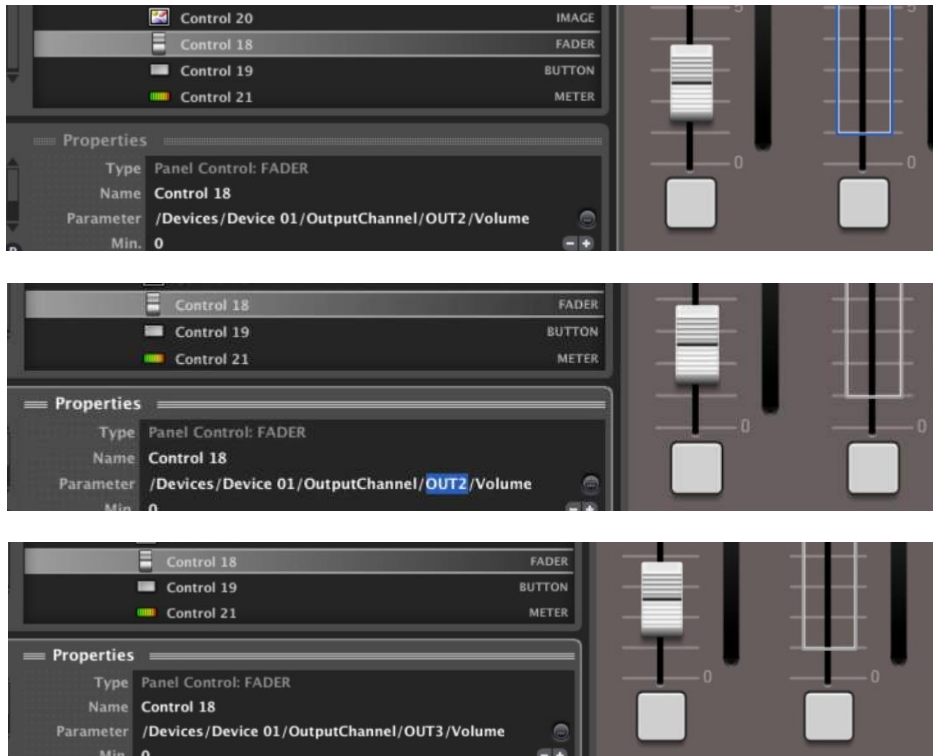

A parameter text in white colour means it's assigned to a valid option, meanwhile a red one means a non-existing or not compatible parameter assignment for the control under edition:



There is a special type of button called *Button Multi* that can operate simultaneously several controls of one or more hardware devices with a single keystroke in a UCP. The following example shows a button of this type that has been programmed to function as a MUTE for input channel #1 in the 5 MIMO88 units of the project. Pressing this button in our UCP is equivalent to press the channel #1 mute control on the 5 MIMO88 of the system.

Each time you press the "+" symbol (Add Parameter) in the upper right corner of the **Param** selection window, you can add a parameter to the list of simultaneous functions managed by the control in the UCP.

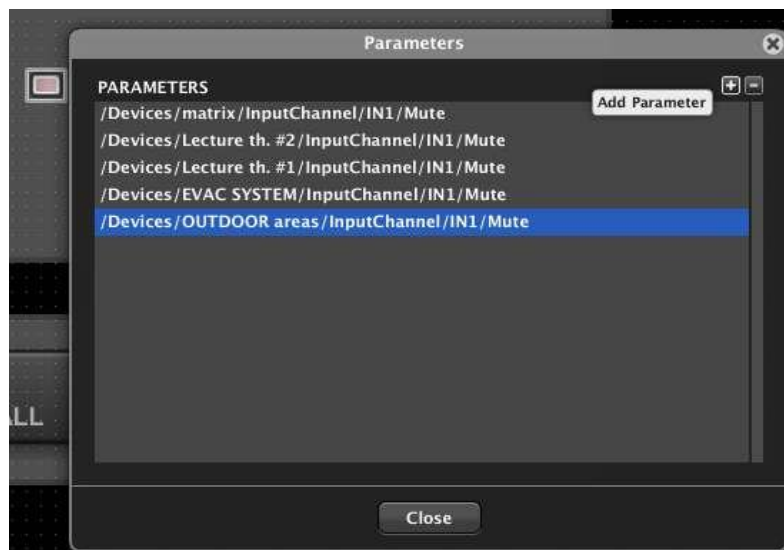
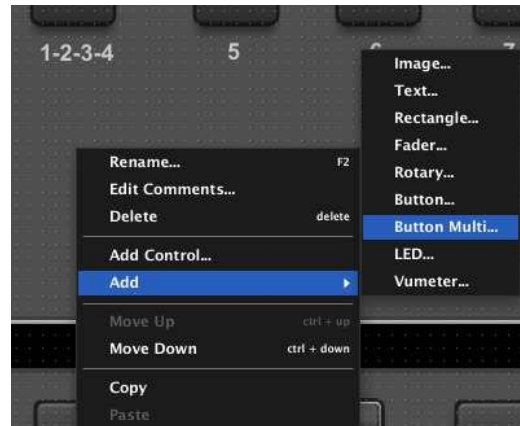

When such a button activates MUTES, as each of these MUTES features a Direct/Reverse setting, this type of UCP button can simultaneously activate a MUTE control and deactivate another one:

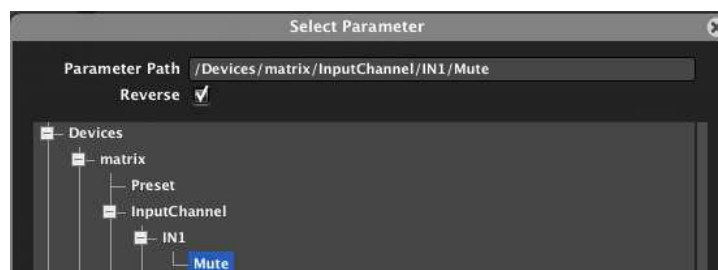

Another option for a button-type control is to be linked to a "Virtual" control rather than to an existing real control of a hardware unit like a MUTE. A "Virtual" control is not associated with any specific function of a project hardware unit:

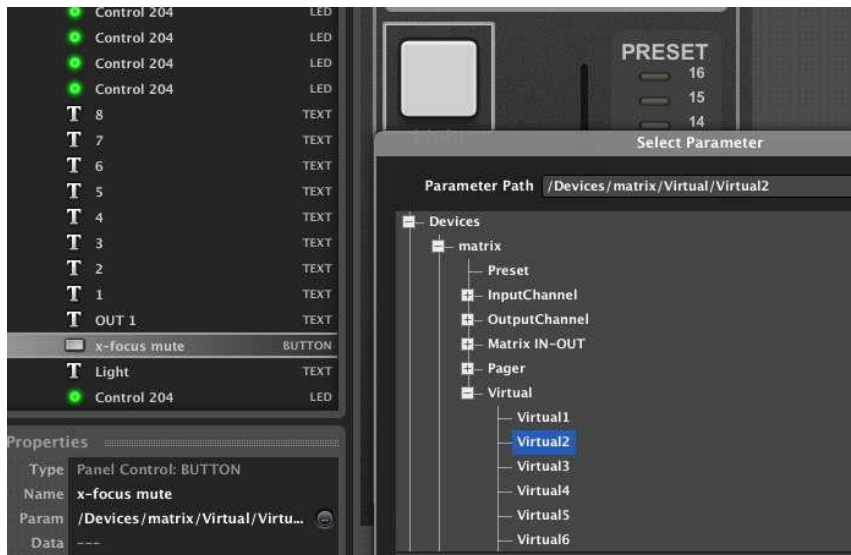

This virtual control can then be used as input for a project event:



Thus, a UCP button could be used for example to activate a MIMO88's GPO or as a compound digital event input, a type of event that uses Boolean logic operators (AND, OR, NOR, XOR, etc..) to trigger an action depending on the status of various inputs. For example, an event of this type could be "if the GPI #1 of the MIMO88 named OUTDOOR AREAS is closed (AND) a specific UCP button is activated, the Emergency Preset should be recalled in this MIMO88 unit".

Another possible use of a virtual control (a rotary knob in this case) is to operate as a selector in a carousel list of inputs or Presets. Thus, an UCP will have the same functions as the selector of a WPTOUCH hardware control:



The virtual selector from the previous image, created in the REMOTES section of a MIMO88, can now be remotely controlled from a UCP:



It is also possible to create a UCP virtual selector that is not a rotary control but a series of buttons, each being assigned to a carousel list. In the following example, we see a carousel list of 4 items (Presets in this case). The right column has a number of discrete values which are those that each selection button must communicate when it is pressed to point to the corresponding item in the carousel list:

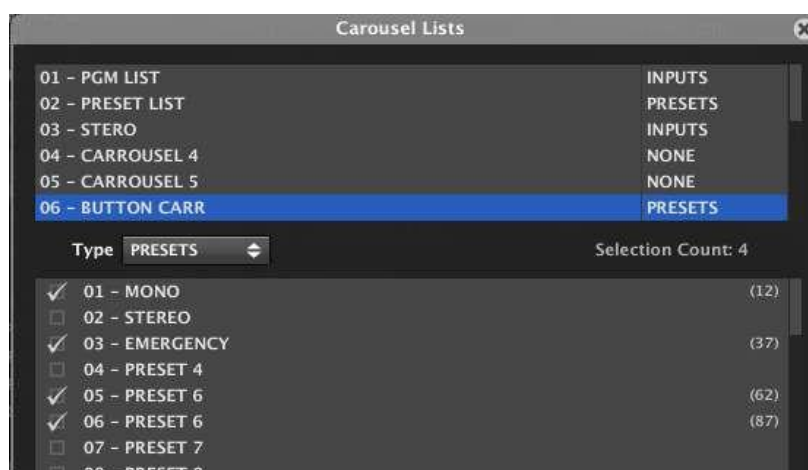

We will have therefore to include 4 buttons in our UCP, with the following control information:

- Key 1: select Preset 1, value 12
- Key 2: select Preset 3, value 37
- Key 3: select Preset 6, value 62
- Key 4: select Preset 7, value 87



In our example, each one of these buttons has to operate the virtual control #16, which is the one we selected as control for our virtual selector in the REMOTES section:

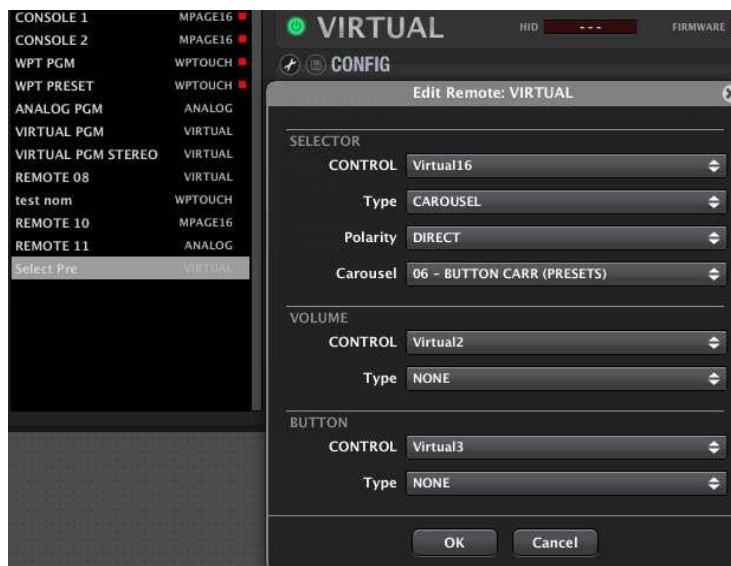

When you press one of these buttons, the virtual control #16 should take the corresponding value among the 4 ones in the table above, value 12 for the first button, value 37 for the second button, and so on. To enable this function for each button, you must follow the following steps (for the previous example):

- Select the virtual control #16 for **Param** in the Properties
- Check the **Push Only (*)** checkbox
- Enter the corresponding value (12, 37, 62 or 87) in the **Data** field

(*) A standard button always sends a value of 100 when pressed and 0 when released, an ideal behaviour to recall a specific preset or activate a MUTE. When it's necessary to send a single specific value when pressing the button and nothing when releasing it, as it is the case with this Presets selector, the Only Push checkbox should be checked.

The settings for each button could therefore be:



LED indicators can also be associated with virtual controls and you can define the **Data** value such controls should have for the LED to light up.

In the following example the virtual control #16 is associated with two LED indicators, lighting the first one when the control takes the value 62 and the second when the virtual control #16 is equal to 87. In both cases, the value 62 or 87 of the Data field has been manually entered:



Please note that when a LED is linked to a parameter that can only take two values, 0 or 100, off or on, the Data field is unavailable because it's not possible to freely assign a specific value to light the LED. In the following example this happens when you link a LED to a MUTE function, which can only have two possible values:

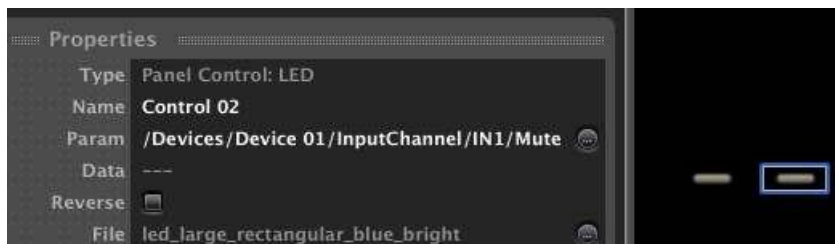

13.4. Management of UCP from remote devices

Fundamentally, any remote device working as a web client (WPmSCREEN / WPNETTOUCH, PAGENETDN, computer, tablet, smartphone, etc..) and pointing with a web browser to the IP address of the web server device (WPmSCREEN / WPNETTOUCH, PAGENETDN or MIMO4040CDN, MIMO7272DN unit running the project or computer which runs the EclerNet Manager application with the project loaded) will display the list of available UCPs in the project. The following example shows an EclerNet Manager project containing 4 UCPs (left image) and how they are displayed by default as a list in the remote browser window, here with Google Chrome (right image).

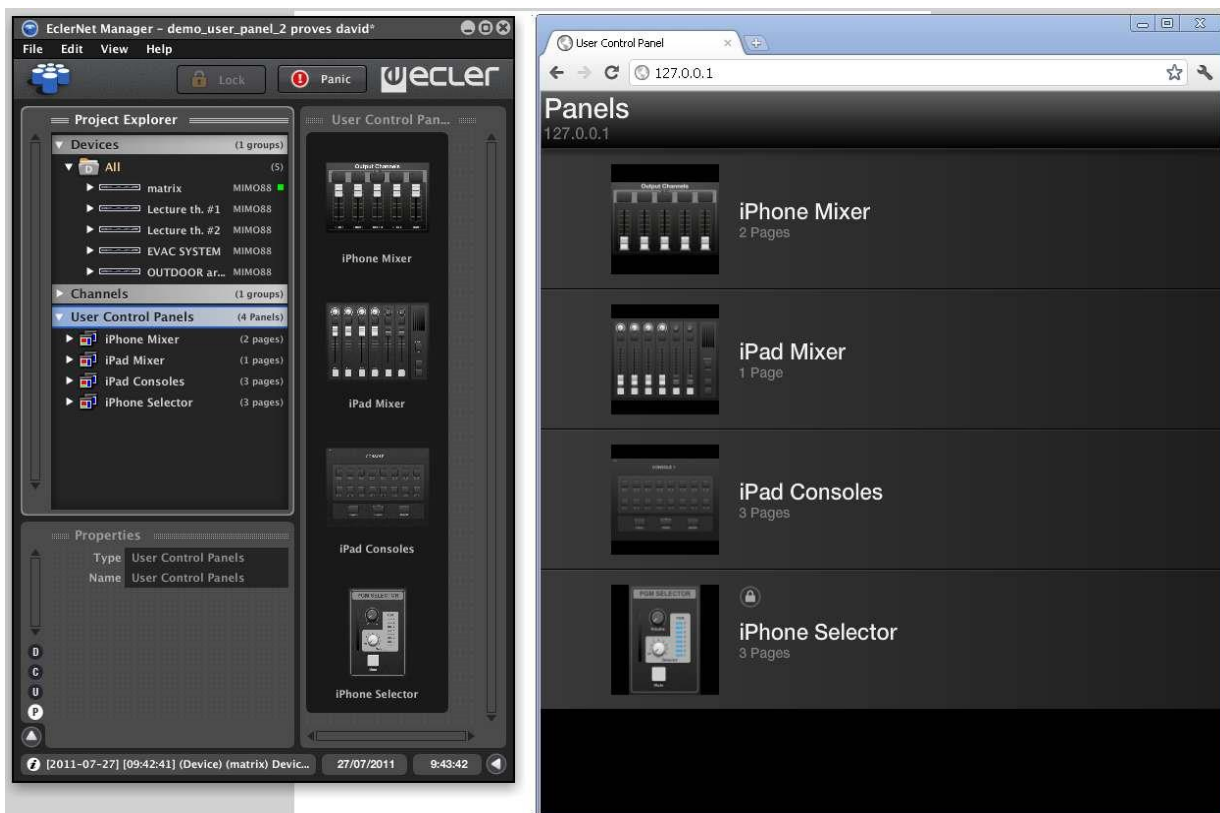

Clicking on one of them will open the first page of the panel. The next pages can be scrolled with the arrow keys or by clicking and dragging horizontally:



By default, UCPs are freely accessible from any remote client (**Users** parameter setting is "All" for these panels). You can also define a specific list of system users who can access each panel, by clicking on the **Users** parameter and selecting the user accounts (existing in the project) you want to include:

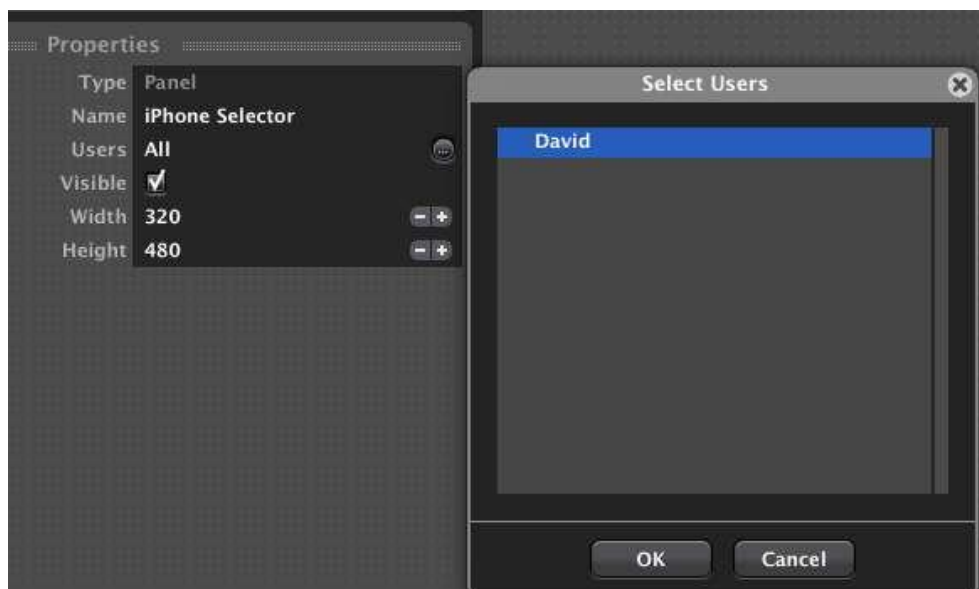

In this case, to recall a UCP, you must enter the user ID and the password of the account:

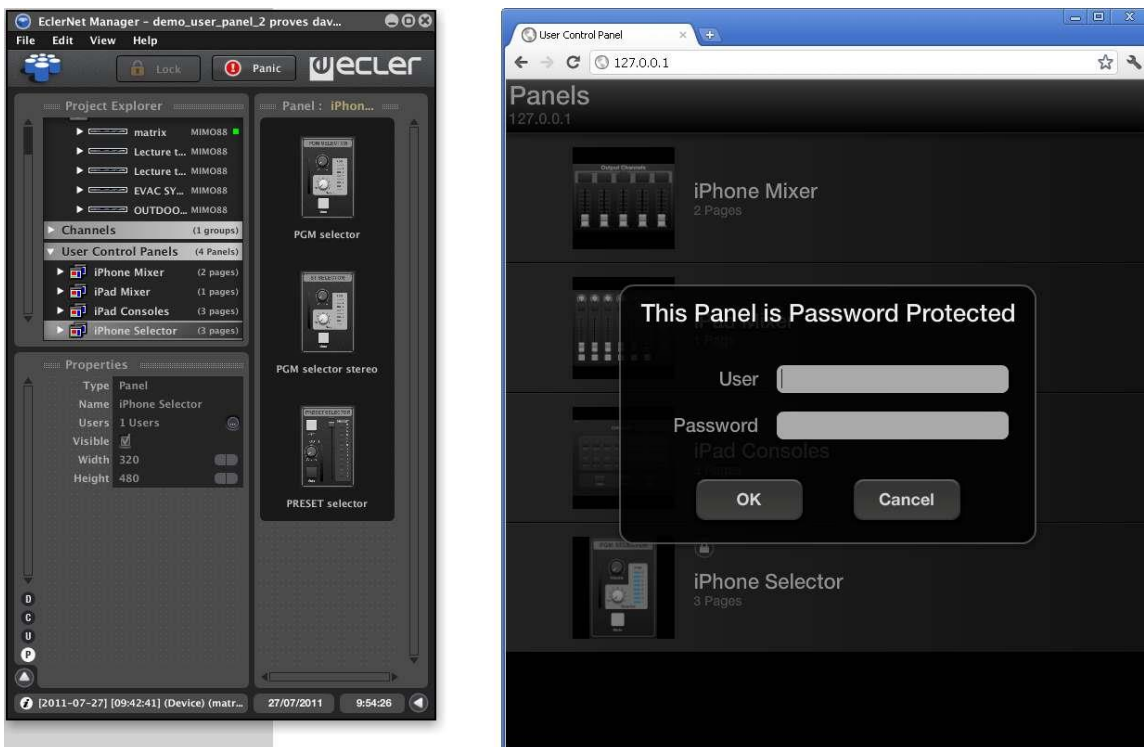

The user name and his password should have been previously defined when creating the user accounts of the project:



Personal computers that use a Web browser for remote access to the UCPs should always use the latest available version for the browser and its Adobe Flash® graphics technology support (HTML5 support included from ENM v6.0 onwards, SEPT 2020).

Apple® devices like iPhone and iPad need to install a free application to be compatible with EclerNet Manager UCPs, since these ones use Adobe Flash® graphics technology (HTML5 support included from ENM v6.0 onwards, SEPT 2020).

From EclerNet Manager v4 onwards, new Ecler UCP v2 applications are available:

<https://itunes.apple.com/us/app/ecler-ucp-v2/id1163815045?mt=8>

Devices based on Android® operating system can also use a free application that streamlines the remote operation of the UCPs compared to its implementation through a conventional web browser. New v2 version available:

<https://play.google.com/store/apps/details?id=air.com.ecler.ucp2>

Ecler UCP v2 version includes these main features:

- **Auto-zoom** option, to automatically adapt the UCP panels to the client device screen resolution
- **Auto-load first panel** option: it automatically shows the first panel in the project after the client-server connection starts
- **Multi-touch support** for client devices screens
- **Compatibility with UCP v1** system (panels created and running with older EclerNet Manager versions)

13.5. EclerNet Manager "hidden" mode and direct access to projects and UCPs

EclerNet Manager can directly load a project at startup, and even run in "hidden" or minimized mode, employing some command line parameters. These parameters can be included in the properties of a shortcut to the application or in a batch file execution, and can even run from the Windows startup, so that for example the following sequence automatically runs without user intervention when the computer starts:

- EclerNet Manager starts
- EclerNet Manager loads a particular project specified in the command line
- EclerNet Manager synchronizes the project with the installation hardware devices without prompting the user (always chooses the "Send Status to Physical Device" option)
- EclerNet Manager is permanently minimized, displaying a blue round icon in the Windows notification area (bottom right corner of the screen)

The previous example is an ideal working mode for a daily and automatic use of the system. Hardware remote users through UCPs do not know what lies behind the control application they have on their respective screens, and don't have to worry about running any additional software. It is also a very good practice for security reasons (to avoid unwanted changes of the project) and especially in those cases where a single computer operates as a webserver, running EclerNet Manager, and as a web client, running UCPs from a web browser.

The **project name** and the **-HIDDEN** parameter must be used in the command line to work with EclerNet Manager in this mode. In the following example a direct access to EclerNet Manager has been edited, adding the **demo_user_panel_1.enp** project and the **-HIDDEN** parameter to your command line:

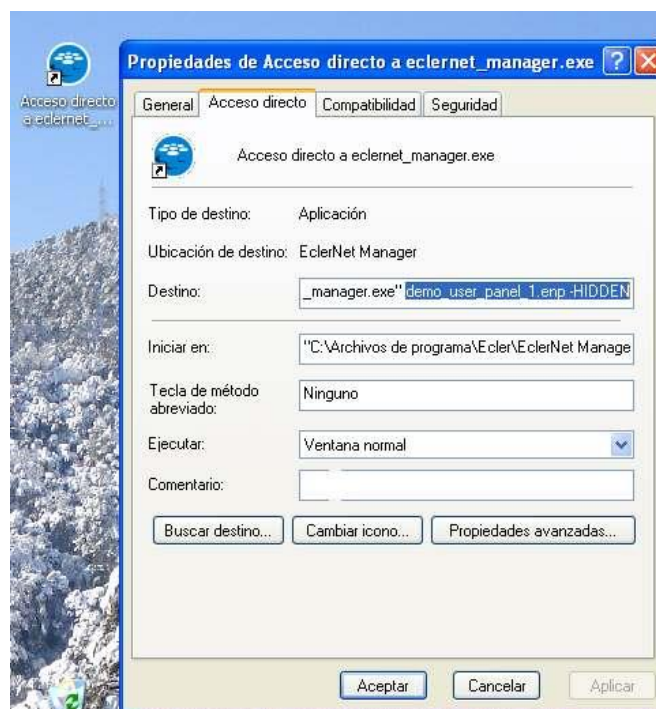

Running this shortcut will start EclerNet Manager in minimized mode, showing the blue round icon in the Windows notification area:



If the project has password protection, a password will be required to maximize the application by pressing the right mouse button on the icon and selecting "Show EclerNet Manager":

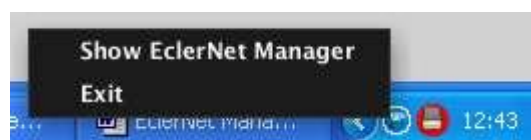

A batch file is a simple text file containing a series of lines with Windows commands and saved with the **.BAT** extension.

A batch file for EclerNet Manager has a very simple syntax if both project and batch file are located in the same folder as the EclerNet Manager executable file or **eclernet_manager.exe** (usually C: \ Program Files \ Ecler ...). If you want to run the batch file from another location (for example, from the Windows desktop), the easiest way to do this is to create a shortcut pointing to this batch.

If the file name of the project file or UCP panel to recall contains blanks, you'll need to insert it within quotes in the command line. To avoid potential problems in this names, it is recommended to replace blanks with underscore character. Example: **example_project** instead of **example project**

Here are some examples of possible commands to be included in batch files:

- Loading a project named **my project.enp** in normal operation mode (EclerNet Manager application will be visible, not minimized):

@start eclernet_manager.exe "my project.enp"

- Loading a project named **my project.enp** in minimized operation mode (EclerNet Manager is not visible, and appears as a blue round icon in the Windows notification area, in the lower right corner of the screen):

@start eclernet_manager.exe "my project.enp" -hidden

- Loading a project named **my project.enp** in minimized operation mode and automatically displaying a Control Panel (UCP) called **my panel** with the default Internet browser for your computer. This example is valid when both EclerNet Manager and the internet browser with UCP are running on the same computer:

@start eclernet_manager.exe "my project.enp" -hidden -launch_panel="my panel"

And this is what a batch file looks like as in the previous example (created with Windows Notepad):

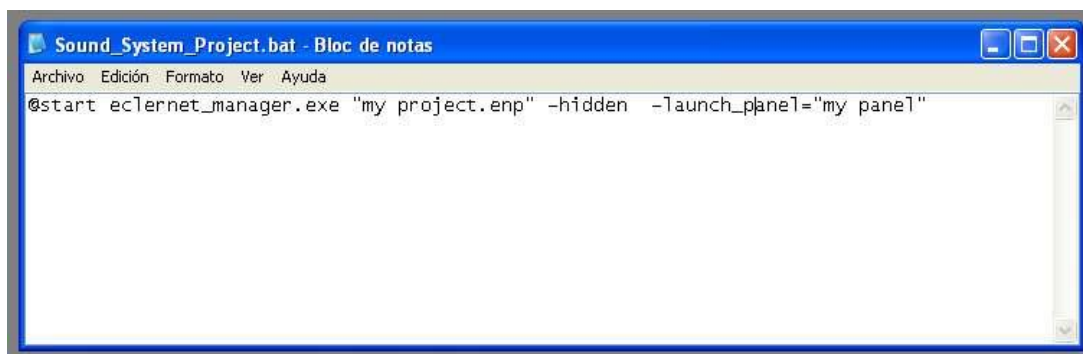

If the project file, the batch file and the EclerNet Manager executable are located in different folders, the syntax becomes more complex.

The following examples assume that the EclerNet Manager application has been installed in the default folder (`C:\program files\Ecler\EclerNet Manager\eclernet_manager.exe`) and the project file in a folder called

`C:\program files\Ecler\EclerNet Manager\projects.`

Do not forget to put names containing blanks in quotes. By using quotation marks, the Windows **START** command can interpret the quoted text as the title of the window, add any title (or any character between the quotes, as in the examples) to prevent this effect. See any batch file creation manual if you need more assistance in this regard.

These are examples for batch files that run a project named `my project.enp` using the full pathname of the files involved:

- Loading a project named `my project.enp` in normal operation mode (EclerNet Manager application will be visible, not minimized):
`@start "" "C:\program files\Ecler\EclerNet Manager\eclernet_manager.exe" "C:\program files\Ecler\EclerNet Manager\projects\my project.enp"`
- Loading a project named `my project.enp` in minimized operation mode (EclerNet Manager is not visible, and appears as a blue round icon in the Windows notification area, in the lower right corner of the screen):
`@start "" "C:\program files\Ecler\EclerNet Manager\eclernet_manager.exe" "C:\program files\Ecler\EclerNet Manager\projects\my project.enp" -hidden`
- Loading a project called `my project.enp` in minimized operation mode and automatically displaying a Control Panel (UCP) named `my panel` with the default Internet browser for your computer. This example is valid when both EclerNet Manager and the internet browser with UCP are running on the same computer:
- `@start "" "C:\program files\Ecler\EclerNet Manager\eclernet_manager.exe" "C:\program files\Ecler\EclerNet Manager\projects\my project.enp" -hidden -launch_panel="my panel"`

If you need to directly recall a control panel or UCP (that does not appear by default in the initial list of available UCPs) from a client PC (a different PC from the one running EclerNet Manager), you can use a batch file or access the address stored in the browser Favourites or Bookmarks. Here are both methods:

- Example using a batch file on a client PC to directly call a UCP panel named **my panel** with the default Internet browser used on the PC. The example assumes that the IP address of the PC running EclerNet Manager (the web server) is **10.11.0.23**:

@start <http://10.11.0.23/go.html?panel=my%%20panel>

The syntax must be very accurate: instead of using quotation marks, if the UCP name contains blanks, replace those blanks with the %%20 characters (twice % followed by 20)

- You can get the same result by typing the address below directly into the browser address bar. You can also include it in your browser Favourites or Bookmarks to easily retrieve the UPC in the future:

<http://10.11.0.23/go.html?panel=my%%20panel>

The syntax must be very accurate: instead of using quotation marks, if the UCP name contains blanks, replace those blanks with the %%20 characters (twice % followed by 20).

13.6. Error Message from the web server service

When running the EclerNet Manager application, it automatically tries to start the web server service in the background, thus allowing client devices to retrieve and manage UCPs that have been included in a project. Sometimes EclerNet Manager can't launch the web server service, basically when another web server type service (Skype, Apache, etc.) is running and/or the **TCP 80** port is occupied.

In such cases, the following warning message is displayed:

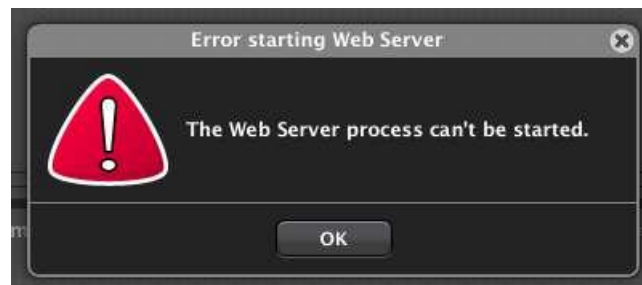

If you click on **OK** EclerNet Manager will run normally, but the web server service is not enabled, making it impossible to connect from client devices and use the project UCPs. Clients will display error messages like this one if you try to connect to the web server:

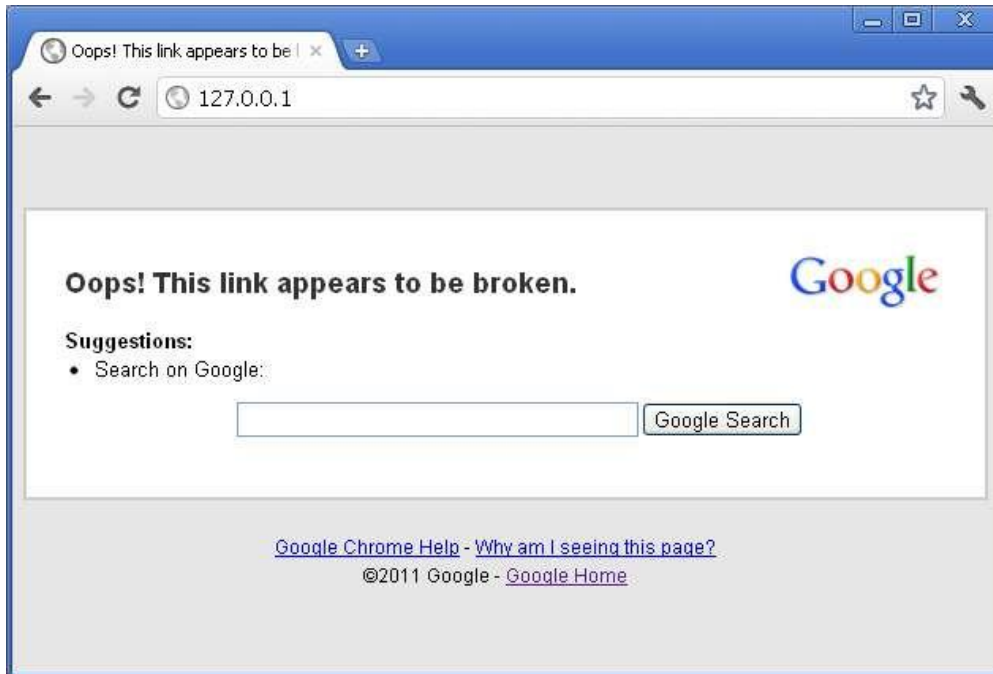

By definition, a single computer cannot run two web server services occupying simultaneously the same TCP port.

14. WPNETTOUCH DEVICE

14.1. Introduction

Note, May 2019: WPNETTOUCH is the substitute device for the former WPmSCREEN, a touchscreen control device, including the same UCP (User Control Panels) control philosophy, as well as many enhancements compared to it, being the main ones:

- IPS, 10.1" display
- Capacitive & multitouch touch panel
- PoE DC supply compatible + external DC Power supply compatible (included)



WPNETTOUCH is a device of the EclerNet family that can be programmed to control one or more networked EclerNet devices; you can even control a full audio / video facility combining a multitude of different **EclerNet and video** devices: MIMO4040CDN / MIMO7272DN, MIMO88, MIMO88SG, MIMO1212SG, NXA-series digital audio managers, NXA-series multi-channel amplifiers (Digital Audio Managers), DUO-NET players, NPA-series stereo amplifiers, **Ecler VEO series** video devices, etc.

Additionally, it can store and execute a project previously created using EclerNet Manager, to perform as a web server for the UCPs (panels) included in this project.

It features a 10.1" IPS screen with multi-touch capacitive panel, able to display the graphic User Control Panels (UCPs) that have been programmed in the EclerNet Manager application software; this screen is the interface between the end user and the associated network of EclerNet and VEO series video devices in an audio / video installation.

A WPNETTOUCH can be used as:

- A UCP web client of another device acting as a UCP web server (another WPNETTOUCH / WPmSCREEN, PAGENETDN, a MIMO4040CDN, MIMO7272DN or a computer running EclerNet Manager)
- A UCP web server for the installation: a project including the hardware devices (MIMO4040CDN, MIMO88, MIMO88SG, MIMO1212SG, NXAs, VEO series video devices, etc.) and the UCPs is transferred from EclerNet Manager to the WPNETTOUCH unit; then the WPNETTOUCH operates as a UCP server for other potential UCP clients, such as computers, Android devices (tablets, smartphones) or Apple devices (iPad, iPhone, etc.)
- Its own web client: a project including the hardware devices (MIMO4040DN, MIMO88, MIMO88SG, MIMO1212SG, NXAs, VEO series video devices, etc.) and the UCPs is transferred from EclerNet Manager to the WPNETTOUCH unit; then the WPNETTOUCH unit operates as a UCP server for any UCP clients as well as being its own UCP client

The IPS screen of the WPNETTOUCH has a native resolution of 1280 x 800 pixels. The panels that it will show can be managed in two different ways:

1. With **no auto-zoom**: any image larger than 1280x800 pixels contained in a UCP (as a panel background image, for example) may not be displayed in its entirety, being partly outside of the visible surface of the screen. It is therefore recommended to take this into account during the design process (from the EclerNet Manager application) of the UCPs that will be subsequently used as UCP clients on the WPNETTOUCH units.

However, the WPNETTOUCH supports the inclusion of images in the UCPs with a maximum size of 2048 x 2048 pixels, but as mentioned above, a maximum portion of 1280 x 800 pixels of such images is displayed. Any image with a size greater than 2048 x 2048 pixels will be ignored but the UCP will operate correctly, except it will display the default wallpaper (dark gray).

2. With **auto-zoom**: this option, when enabled from EclerNet Manager, or from the local configuration menus in the hardware unit, for a given WPNETTOUCH unit, will automatically zoom the panels to adapt them to the 1280x800 resolution, thus shown in their entirety:



14.2. Local Configuration of the Unit

WPNETTOUCH settings and configuration menus can be accessed locally from the touch screen of the device itself. The same settings are remotely accessible when the screen is under the control of a remote computer running the EclerNet Manager application.

Local access to the configuration menus can be done by clicking on the SETUP icon, from the home page of the unit:



The available configuration menus are the following:

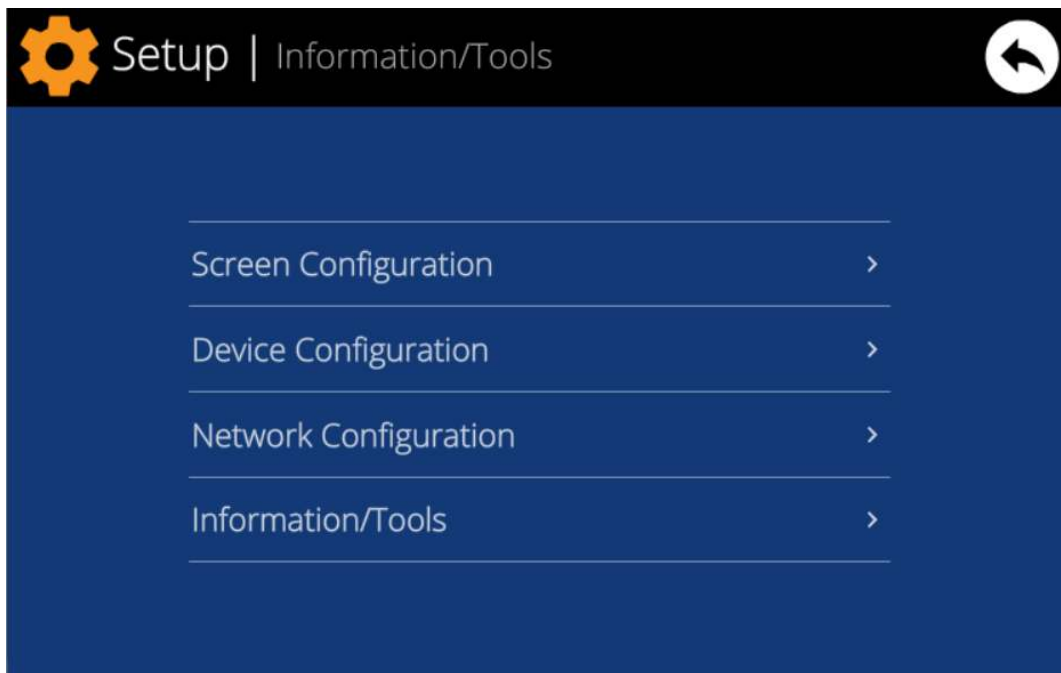

14.2.1 Screen Configuration menu

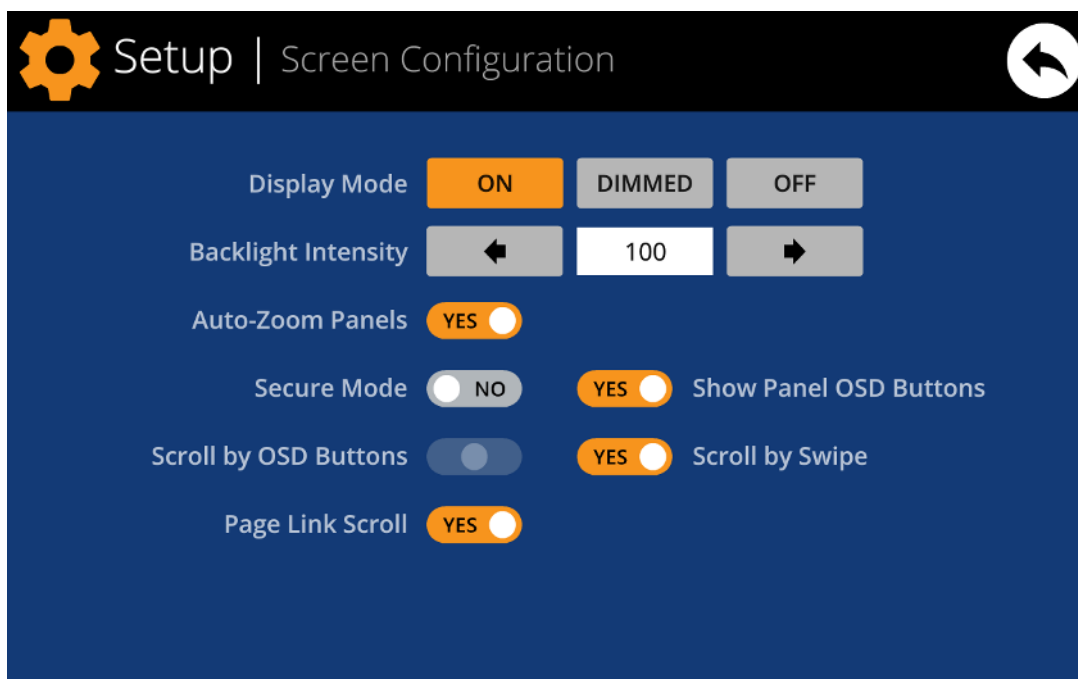

This menu allows setting different parameters affecting the displayed items and controls on the screen of the unit:

- **Display mode:** behaviour of the screen dimming in sleep state, after 10 seconds of user inactivity on the touch screen. The available modes are: ON (always lit), DIMMED and OFF (unlit)
- **Backlight Intensity:** brightness intensity of the screen when it is not in sleep mode
- **Auto-Zoom Panels:** when activated, the graphic control panels (UCPs) are automatically resized to match the maximum visible area, no matter the original resolution they were created in the EclerNet Manager project file.
- **Secure Mode (from ENM v6 onward):** when activated, it disables the OSD buttons and Scroll by Swipe function. The only way to have access to the main toolbar and Home menu, is pressing the bottom corners of the screen for more than 5 seconds.
- **Show Panel OSD Buttons:** enables/disables the superimposed display of the navigation buttons in the corners of the displayed UCPs. The top corner buttons can scroll the panel pages (left and right) and the bottom corner buttons access the icon bar:



Note: even when the buttons are not displayed, they can still be active, so that pressing the top corners activates the horizontal scrolling between the panel pages and pressing the bottom corners displays the icon bar. This is an aspect that must be considered for the layout of the controls (buttons, sliders, knobs, etc.) on each UCP page during its design; the corners must be as free as possible if these OSD buttons will be used for scrolling between pages (top ones) and always free in the case of the bottom ones (icon bar display).

- **Scroll by OSD Buttons:** enables/disables the scroll action between pages pressing the top corners, even the OSD buttons are hidden
- **Scroll by Swipe:** enables/disables the scroll action between pages with a left or right swipe (press & drag) action on the screen
- **Page Link Scroll (from ENM v6 onward):** when a Page Link button is in use, this option allows enabling/disabling the visible scroll effect in order to reach the selected UCP panel page only via Page Link button, which is usually not desired (=disabled).

The icon bar displays new accesses to the horizontal scrolling between the pages of a panel (to the left and right), access to the home page of the unit ("HOME" icon) and exit of the icon bar ("X" icon):

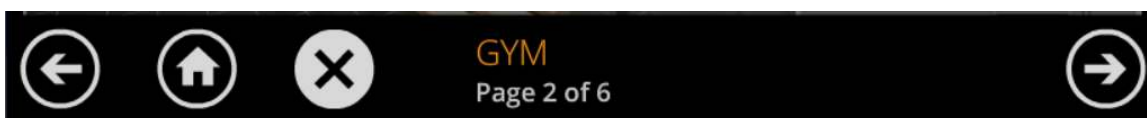

14.2.2. Device Configuration menu

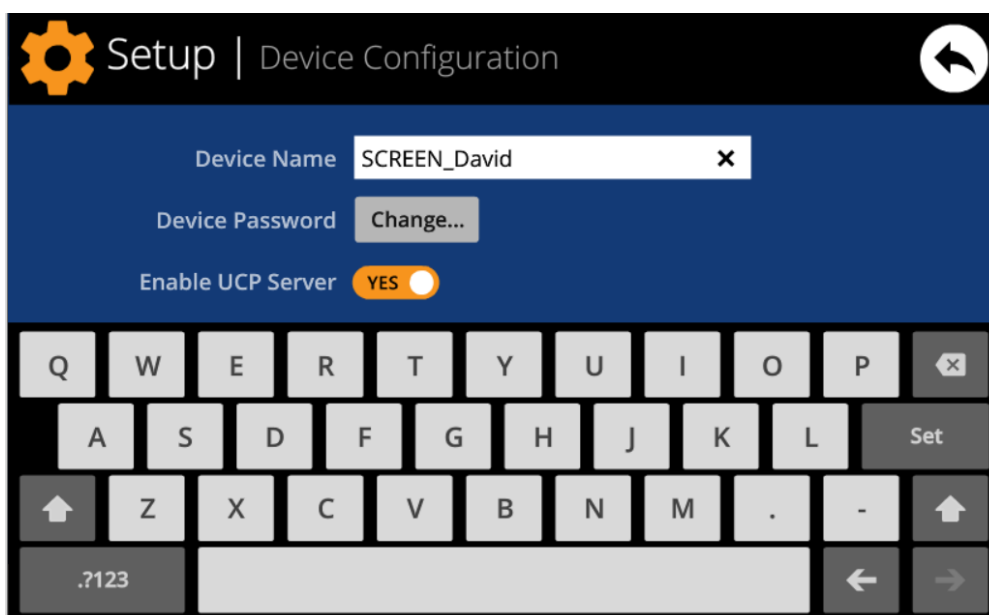

This menu allows adjusting the following parameters of the unit:

- **Device Name:** name of the device, as seen from other WPNETTOUCH / WPmSCREEN devices, as well as from the EclerNet Manager application
- **Device Password:** password for the protection of the device against the editing of its critical configuration parameters, requested for this purpose if enabled (enabled = other than blank password)
- **Enable UCP Server:** enables/disables the embedded UCP server service of the unit
 - **Enabled:** the EclerNet project stored in the unit (“Local Project”) will be fully functional, taking control of the hardware devices that are included in it (MIMO4040CDN, MIMO7272DN, MIMO88, NXA units, etc.) and serving the UCP panels it contains to potential UCP clients on the network
 - **Disabled:** the EclerNet Local Project is deactivated, releasing the control over all included hardware (MIMO4040DN, MIMO88, NXA units, etc.) and, consequently, also ceasing to serve UCPs for clients

Warning: In the disabled status, another device or computer running a project containing all or some of the hardware devices existing in the WPNETTOUCH's Local Project could take control of them. **Just one device and project can take control of the same hardware device at the same time**, so that units controlled by a device must first be released before trying to control them from another device:

- From EclerNet Manager, you can release the devices controlled by the computer through the creation of a new project (File -> New Project), or by disconnecting them from the network one by one (right mouse button -> Disconnect)
- From a WPNETTOUCH / WPmSCREEN, you can release the devices controlled by the unit by setting the Enable UCP Server option on NO

14.2.3. Network Configuration menu

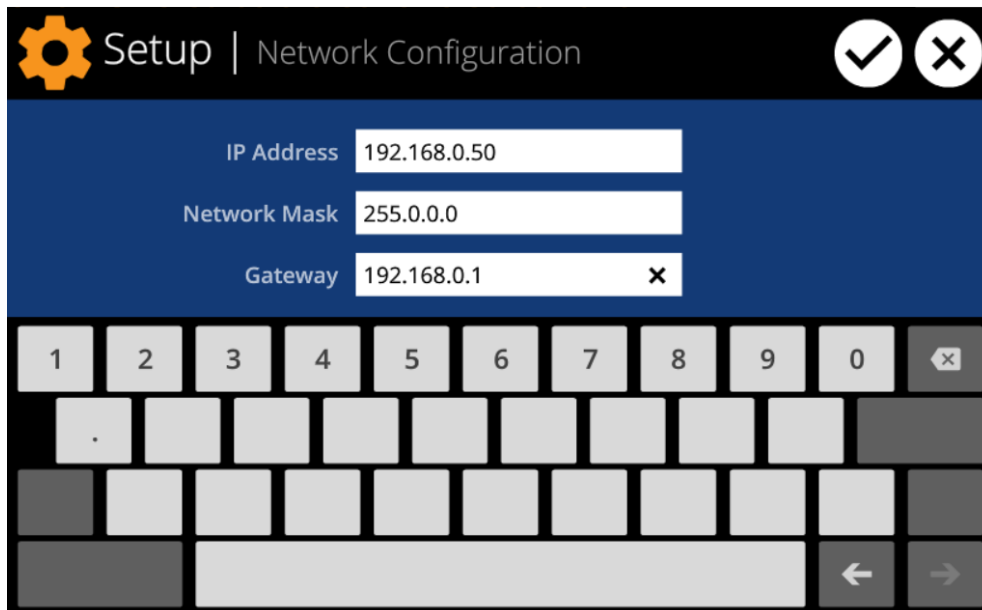

This menu allows modifying the network connection parameters of the WPNETTOUCH unit: IP address, network mask and gateway.

Note: neither the WPNETTOUCH nor any other EclerNet device supports the protocol of dynamic allocation of IP addresses (Dynamic Host Configuration Protocol, or DHCP), so it's always necessary to manually assign them static addresses.

14.2.4. Information / Tools menu

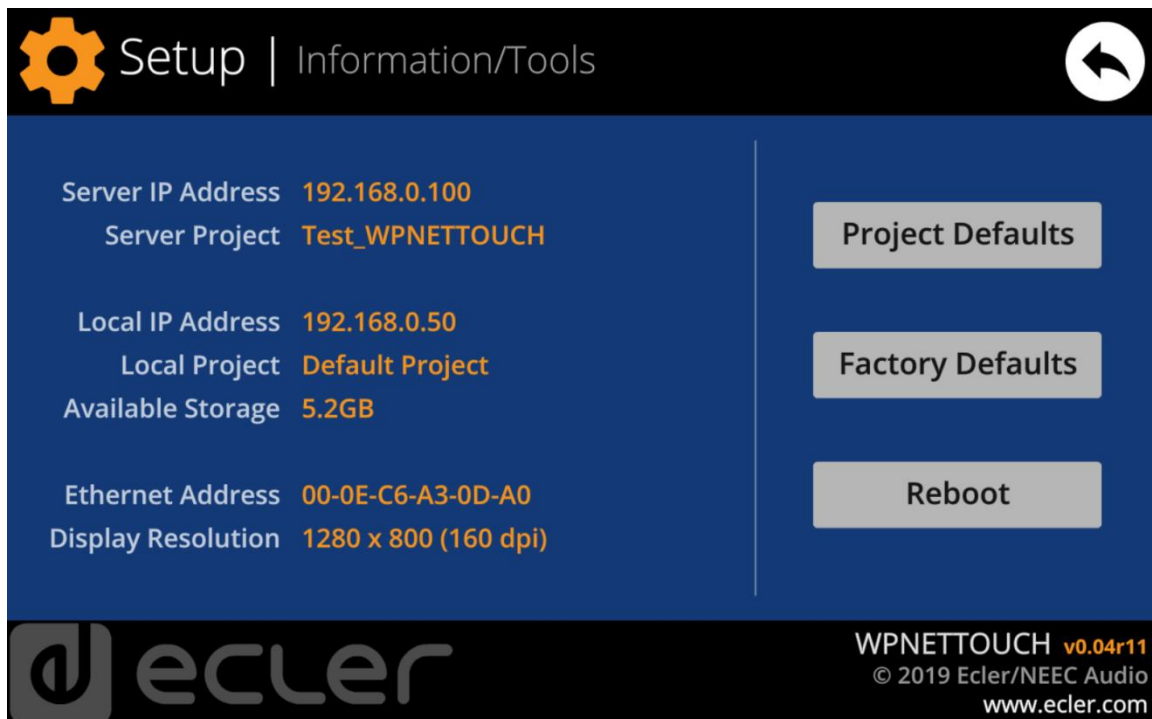

This menu displays the following information:

- **Server IP Address:** IP address of the UCP server device that the unit is connected to, as a UCP client. When the unit is connected to itself as a client, it will show its own IP address (= Local IP Address)
- **Server Project:** name of the project running in the server the unit is connected to as a UCP client (project running on the UCP server of the client)
- **Local IP Address:** IP Address configured for the WPNETTOUCH unit
- **Local Project:** name of the project stored in the internal storage space of the WPNETTOUCH unit. This project can be uploaded to the WPNETTOUCH unit using EclerNet Manager software app
- **Available Storage:** internal storage space available to upload a project file, which would include User Control Panels data and graphics
- **Ethernet Address:** MAC address of the NIC (network interface card) mounted in the WPNETTOUCH unit
- **Display resolution:** native screen resolution of the IPS panel of the unit (1280 x 800)
- **Firmware version:** shown at the lower right hand side corner (in the above example v0.04r11)

And the following restore / reboot options:

- **Project Defaults:** clears the project in memory, replacing it with a blank project, after warning that the process is irreversible:



Project Defaults

Warning: this action will replace the current project with a default (blank) one, losing all the configuration and user data in the current project. Are you sure?

- **Factory Defaults:** clears the entire configuration and all data in the unit, restoring the factory default settings, after warning that the process is irreversible:



Factory Defaults

Warning: this action will bring back this device to its factory defaults. This involves losing your current network configuration, general setup and current project data. Are you sure?

- **Reboot:** reboots the unit:



Reboot

This action will reboot this device, losing network connection for a while and recovering normal performance after the reboot. Are you sure?

14.3. Connection to a UCP Server (“Connect to...” menu)

From the home screen of the unit, the connection icon on the upper side of the screen will give access to the Connection page:



This page allows deciding the UCP server the unit will connect to as a client. The UCP server may be a computer, a MIMO4040DN matrix (yes, it has an embedded UCP server in its engine!) another WPNETTOUCH / WPmSCREEN / PAGENETDN unit or even the same WPNETTOUCH unit. In any case, the UCP server shall host and run an EclerNet Manager project that includes a series of UCPs which can be remotely managed by any UCP client.

It is possible to directly enter the IP address of the server device, using the touch keyboard displayed on the screen, or to select a device from a list of automatically detected UCP server devices, which is accessed by clicking on the grey button with the list icon to the right of the "Connect" button:

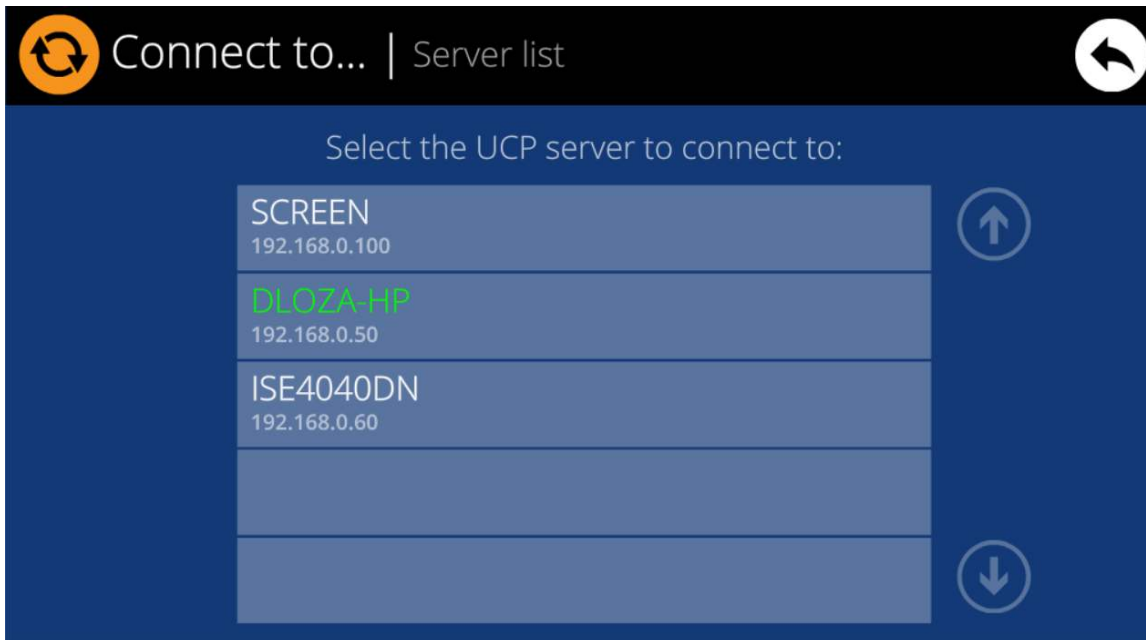

Note: in the list of detected server devices, the name of the WPNETTOUCH unit under control will appear in green (the one matching with the Local IP Address)

After selecting a server unit or an IP address, using either of these two methods, pressing the "Connect" button will confirm the selection and start the process of connecting to the server. If this process is successful, the UCPs that the server makes available for the WPNETTOUCH client will appear on the screen:

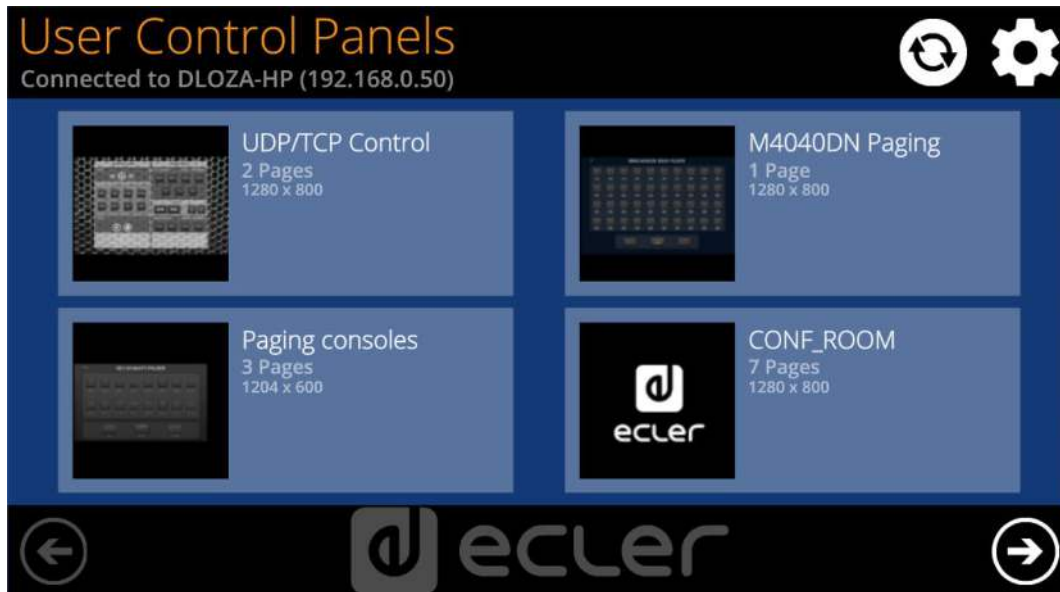

14.4. Unit Configuration from EclerNet Manager

WPNETTOUCH can be included in an EclerNet project like any other EclerNet device, and can be configured from this application.



The available parameters are mostly the same than those accessible from the local configuration of the unit, the main difference being UCP PANELS section, which allows you to decide which panels

the WPNETTOUCH unit will display, among all those included in the running project, as well as the panel that will be displayed when starting the unit.

When the WPNETTOUCH unit has been assigned as a client of a UCP server, it can by default access all of the panels included in the project on the server. If you want to restrict access from the WPNETTOUCH to a set of few panels, you'll need to configure the enabled panels list by pressing the "+" icon (Add UCP Panel) at the top right of the section:

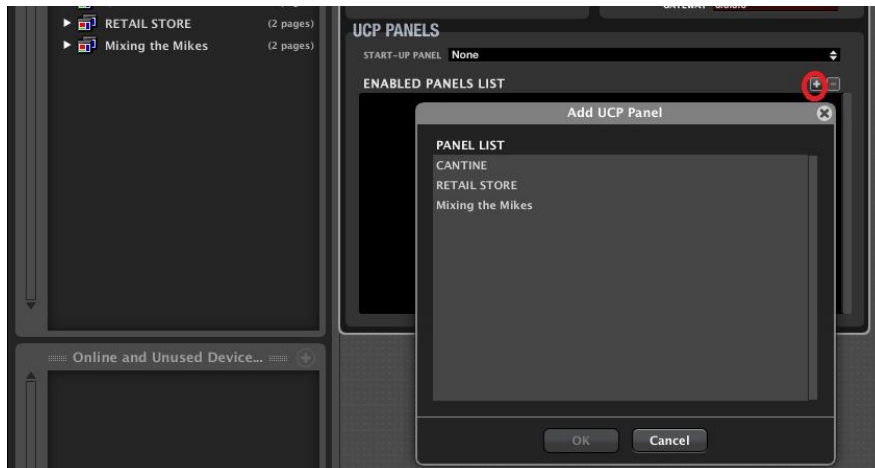

In the following example, among the three UCP panels existing in the project, only "CANTINE" and "Mixing the Mikes" have been enabled to be shown and managed from the WPNETTOUCH:



The result is that only these two UCP panels are displayed on the screen of the WPNETTOUCH, available for management:



Additionally, it is also possible to choose in the list of selected panels the one that will be displayed at the unit start-up, instead of displaying the full list of panels, as it is the case by default:

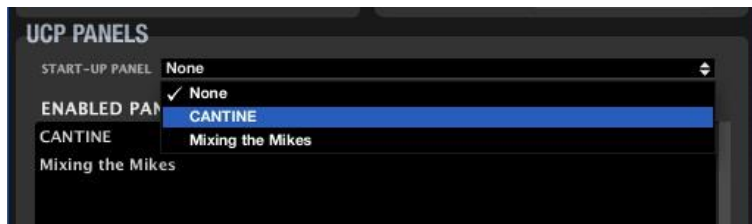

Note: the WPNETTOUCH and its configuration must be included in the project uploaded and running in the UCP server (whether a computer, WPNETTOUCH, PAGENETDN unit or MIMO4040CDN, MIMO7272DN unit) for the options to be effective in the UCP PANELS section:



14.5. WPNETTOUCH as a UCP Server

The WPNETTOUCH can store and execute a project previously created using EclerNet Manager, to perform as a web server for the UCPs included in this project.

The procedure for transferring an EclerNet project to a WPNETTOUCH and enable it as a UCP server is the following:

First, you need to create or retrieve from the EclerNet Manager application (File -> Open) a project that includes hardware and configuration used in the installation (MIMO4040DN, MIMO88 / 88SG and 1212SG, NXA units, etc.), as well as the desired UCP panels and pages in them, using the standard method described in the previous chapters of this manual.

The following image shows an example project that includes a MIMO4040DN and other EclerNet hardware, as well as 7 UCP panels. The green connection icons indicate that the hardware units are "online" and under the control of the computer running the project from the EclerNet Manager application, a proof that the network configuration of the computer and the hardware devices is suitable for a correct communication between them:

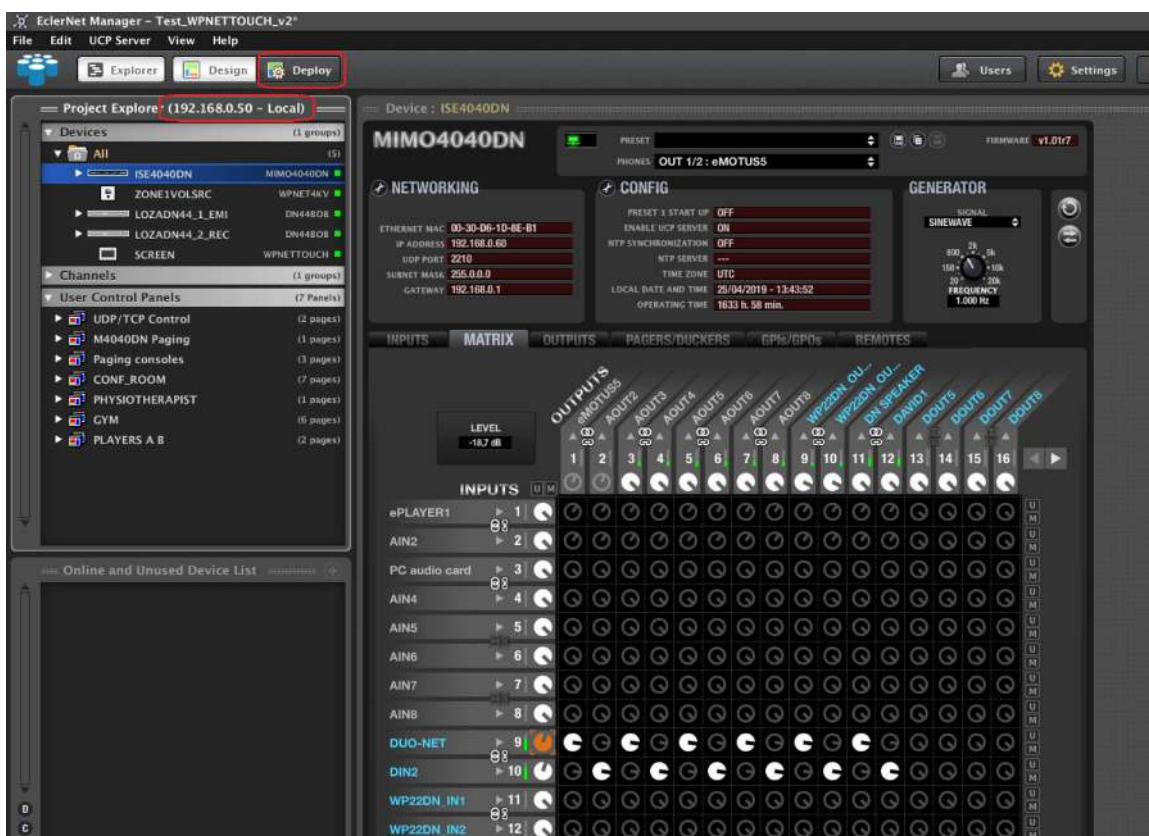

Note: in the above image the Project Explorer window: it indicates that the project is running in **Local** mode, i.e. in the computer whose IP address is displayed, and not (yet) in a WPNETTOUCH unit. In this state, the computer is acting as a UCP server.

It is recommended at this point to check that all the configuration for audio, events, GPls, GPOs, etc. works properly with the associated hardware. In the image, the real audio activity can also be monitored on the level meters of the MIMO and other audio hardware in the project. Another important checking is offered by the UCPs, using for them the project in Deploy mode and any networked UCP client. All of this guarantees that in the future, when the project runs on a WPNETTOUCH, everything will work as expected. Example using a web browser in the same PC as the UCP client, pointing to **localhost** address:

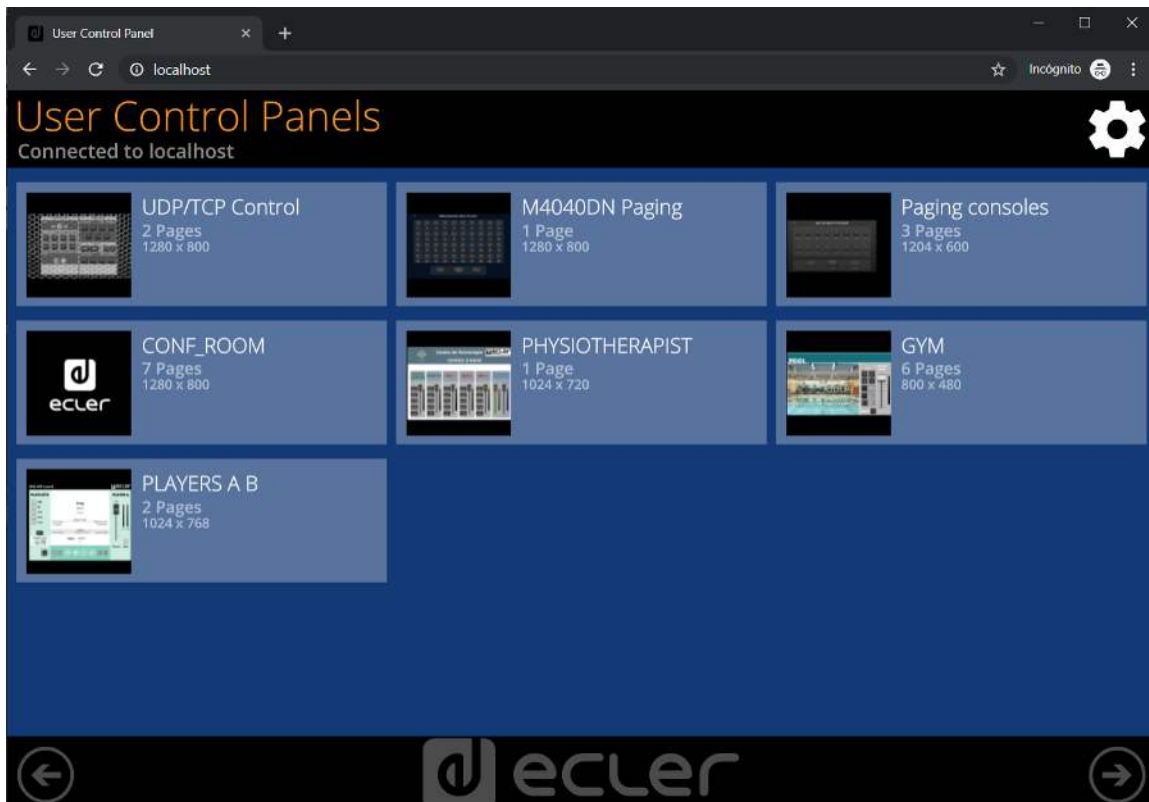

All product characteristics are subject to variation due to production tolerances. **NEEC AUDIO BARCELONA S.L.** reserves the right to make changes or improvements in the design or manufacturing that may affect these product specifications.

For technical queries contact your supplier, distributor or complete the contact form on our website, in [Support / Technical requests](#).

Motors, 166-168 08038 Barcelona - Spain - (+34) 932238403 | information@ecler.com | www.ecler.com