

exeo

Make your messages heard



*Digital Public Address and
Voice Evacuation system*

EN 54 16

EN 54 24

EN 54 4



MAJORCOM:

EN 54 16

EN 54 24

EN 54 4

Optimal performance,

Our ambition is to provide you with the best of our technology, combined with a strong determination

EVOLUTION OF THE NORM, MAJORCOM REVOLUTION

In response to European standards EN 54-16, EN 54-24, EN 54-4, MAJORCOM offers a comprehensive, powerful and technologically innovative sound and voice evacuation system, which leaves no room for uncertainty. EXEO equips Retail, Industrial, Schools, Healthcare, Transportation, Corporate..., regardless of their volume, requirements or characteristics.

Continuous control of the entire system

LATEST-GENERATION USER-FRIENDLINESS

Management is performed via a 4.3" colour LCD touch screen. The software gives you intuitive access to a wide range of functions in a clearly visible manner, adapted to your needs. Its network configuration means that the system can be run locally by PC or remotely via SINEO software. Benefit from our teams' technical skills and availability, on site or by remote maintenance.

A modular and



Management of numerous broadcast and alarm zones

A COMPACT, EXPANDABLE AND SECURE SYSTEM

An all-in-one solution with built-in amplifiers, 2U rack-mountable and expandable.

EXEO can host up to 128 units. The number of zones thus covered by the system is up to 1024 for the zones of diffusion as much for the Alarm Zones or 2048

Lines Speakers in A / B.

EXEO allows up to 40 audio inputs.



minimal footprint

to make it accessible. This is how EXEO was born: a compact and high-end system, unique on the market.

customisable system

NO COMPROMISE ON SECURITY

EXEO continuously controls the operation of its power stations and peripherals:
control of amplifiers, control of Speakers Lines,
control of security remotes stations.

The certification of the EXEO range is a "product" certification which allows an implementation in any type of rack.



*Intuitive
local and
remote
operation*

*An intelligible message
in all circumstances*



COMFORTABLE AND ERGONOMIC STATIONS

The EXEO Master control unit MVA-8120 allows the management of 8 broadcast zones and 8 alarm zones expandable with the addition of extensions units. Stations are interconnected by an FlexNET/Cobranet network via an Ethernet cable (Cat5/6) up to one hundred meters, beyond which the units are connected by optical fiber. The 4.3" LCD screen placed on the front of the Master unit provides the user with simple touch screen. management. It can monitor and operate audio sources and zones from the front panel.

EXEO is equipped with 2 message players up to 99 MP3/WAV messages (Max 12h) controlled via the user interface on the 4.3" LCD screen or remotely via the microphone consoles.

Unrestricted configuration

EN 54 16

EN 54 24

EN 54 4

EXEO's network architecture is based on the Cobranet technology interconnecting (DaisyChain) its "Master" & Are your installations decentralised? Are there many zones to cover? EXEO guarantees the sustainability of

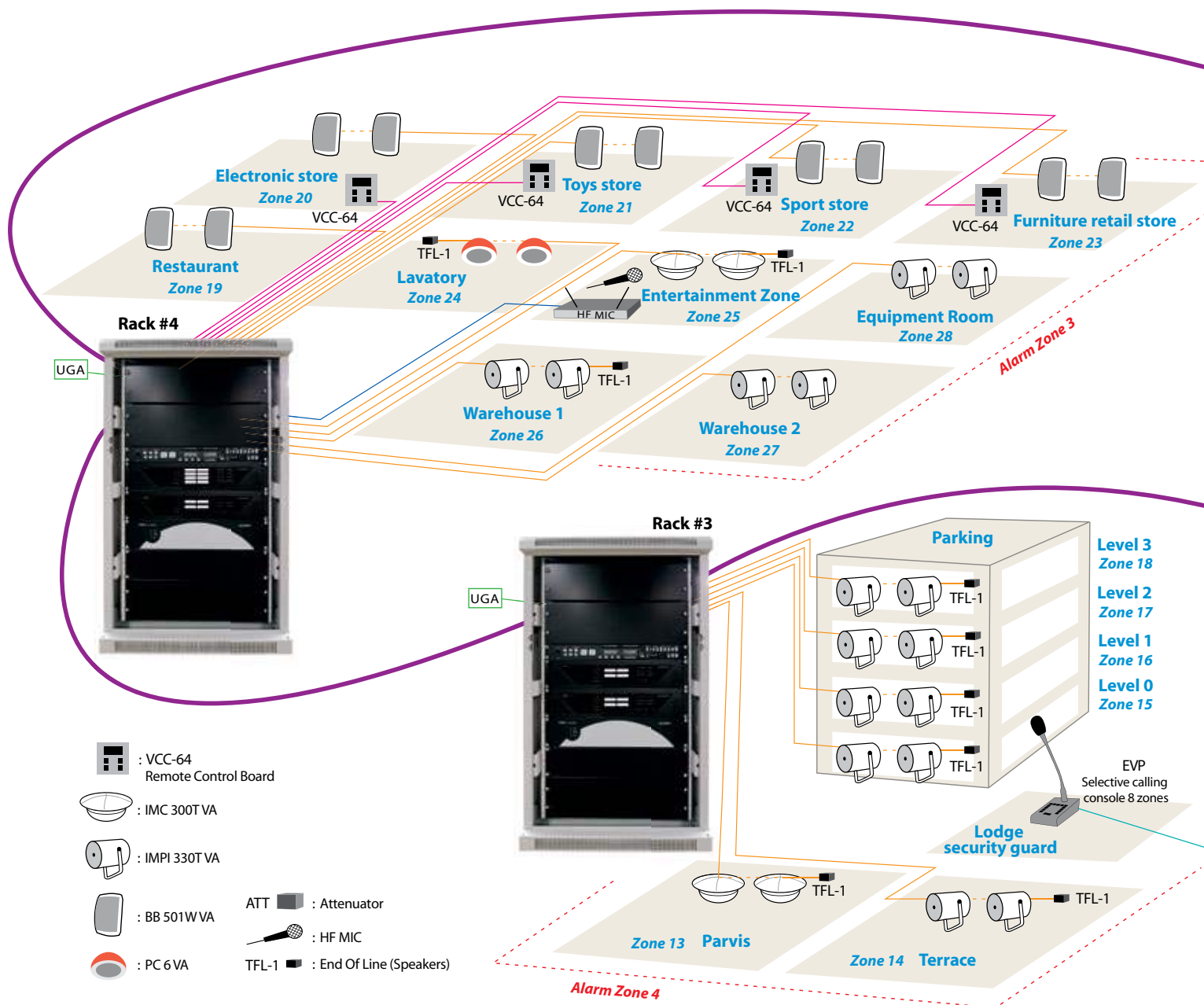

THE PUBLIC IS INFORMED, THEREFORE PROTECTED

EXEO's digital network architectures makes it 100% reliable. Music, information, security alert etc. regardless of the source or nature of the information, your message is delivered in any circumstance.



“Extensions” units. The system can cover 1024 broadcast zones, 1024 alarm zones and 2048 speaker lines (A/B), a freely configured installation.

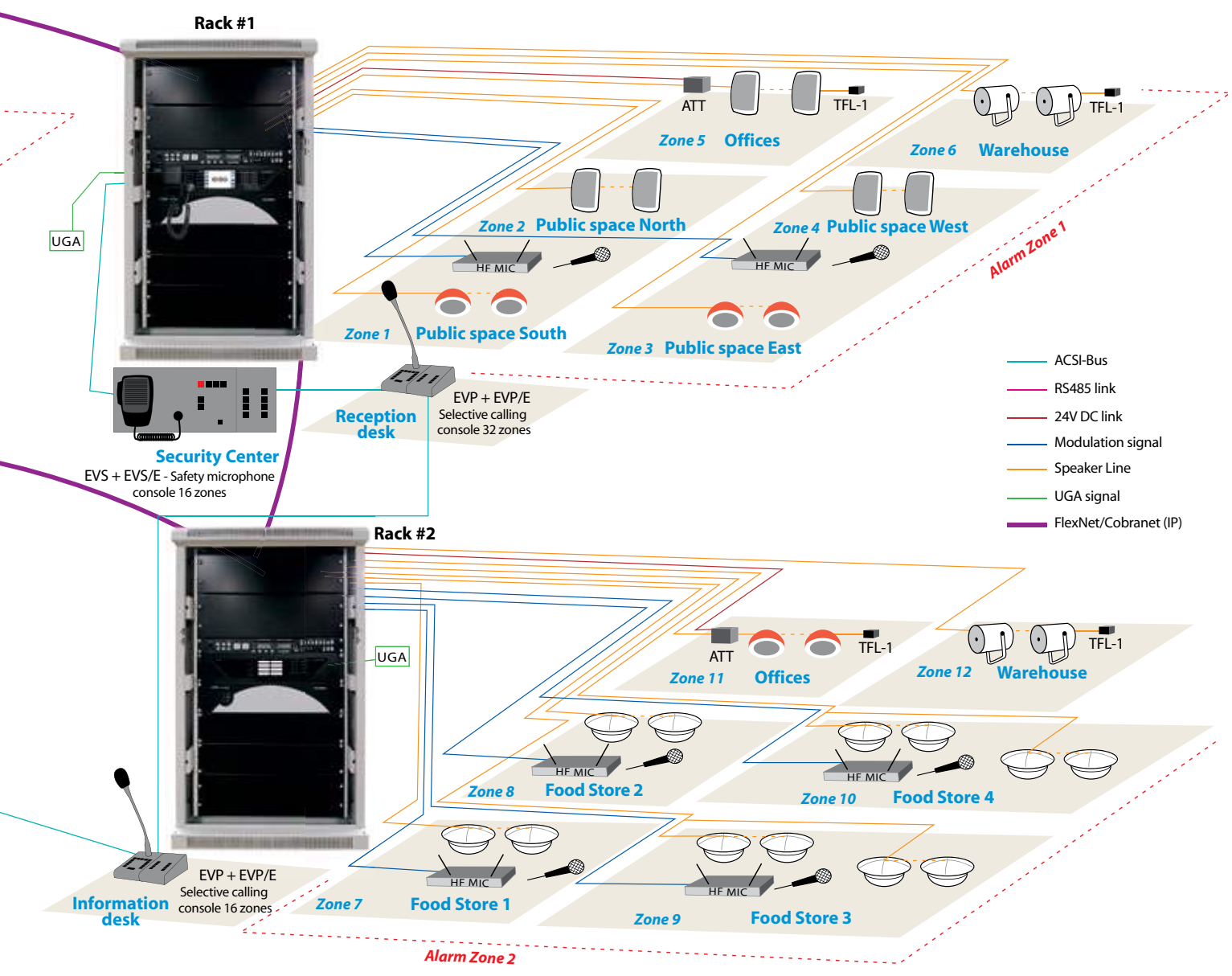

EXEO'S BENEFITS

- “Advanced security system”
- Compliance with European and international Standards
- “Flexible Power” system with integrated class D digital amplifiers
- Modular architecture, scalable installation
- User-friendly, ergonomic, remotely operated solution
- Detailed system monitoring at your fingertips
- Control of speaker lines by impedance or line continuity via an end-of-line element (TFL-1).
- Compact system: space saver, lower energy consumption
- Guaranteed operation of the security system, **even when one of the network cables fails**, thanks to the Cobranet technology. This digital audio network, based on the Ethernet technology, makes it possible to convey digital audio channels and control data.

We are very familiar with your environments and constraints. This is how we can provide you with a smart system, designed to respond to an infinite number of existing and potential situations.



INPUTS - OUTPUTS

VOICE EVACUATION SYSTEM

- Each station can manage 4 or 8 Alarm Zones (1024 in total for a 128-station system).
- 2 message players (Evacuation & Pre-Alert) common to the entire installation.
- On each Alarm Zone, it is possible to configure a pre-alert device with the evacuation.
- A PTT Safety Desk on the front of the Master unit and Controlled EVS Stations. Possibility of extending the number of calling Alarm Zones via the EVS/E interfaces (64 Max).
- 8 Normally Open Dry Contact inputs Controlled by the unit (1 per alarm zone) + a general input for an evacuation trigger. Voltage trigger inputs 24 / 60Vdc via the UGA (Alarm Management Units) card.
- 3 Monitored Dry Contact inputs for Main Power, Battery and Presence Output of the emergency power supply.
- 1 default synthesis output on each station.
- An EMG (EMERGENCY) output.

PUBLIC ADDRESS

- The EXEO master unit MVA-8120 hosts 5 line inputs. Priority management between sources is managed by presets on ducking fonction.
- 32 sources can be added to the network via Cobranet DCO-22 audio interfaces.
- 16 Speakers Lines Outputs in A/B maximum per unit so you can have 2048 peakers Lines total on a complete installation.
- 14 GPIO programmable input / output for preset management or report of an event.
- Up to 8 Remotes Microphone Station (EVP) can be connected and 8 VCC-64 Volume and Channel Controllers.
- Audio outputs available on each equipment to insert external amplifiers.

MESSAGES

- EXEO offers 2 message players MP3/WAV with a total of 99 messages, maximum 12 hours.
- These messages can be triggered by dry contact, on a scheduler, from the Remote Mic Call Stations EVP or by dry contact.
- Adjustable volume for each broadcast zone output or input and amplifier.



"Master" unit MVA-8120



The EXEO system can be easily scaled with EXEO-Extension units that will add extra power and zones to the system.

“Extension” unit SVA-4250



4 Amplification channels
250W Power per channel
1000W Total maximum power

“Extension” unit SVA-8250



8 Amplification channels
250W Power per channel
2000W Total maximum power

“Extension” unit SVA-4500



4 Amplification channels
500W Power per channel
2000W Total maximum power

“Extension” unit SVA-4500L



4 Amplification channels
500W Power per channel 4 Ω
2000W Total maximum power 4 Ω

Example of sound security system, 12 zones

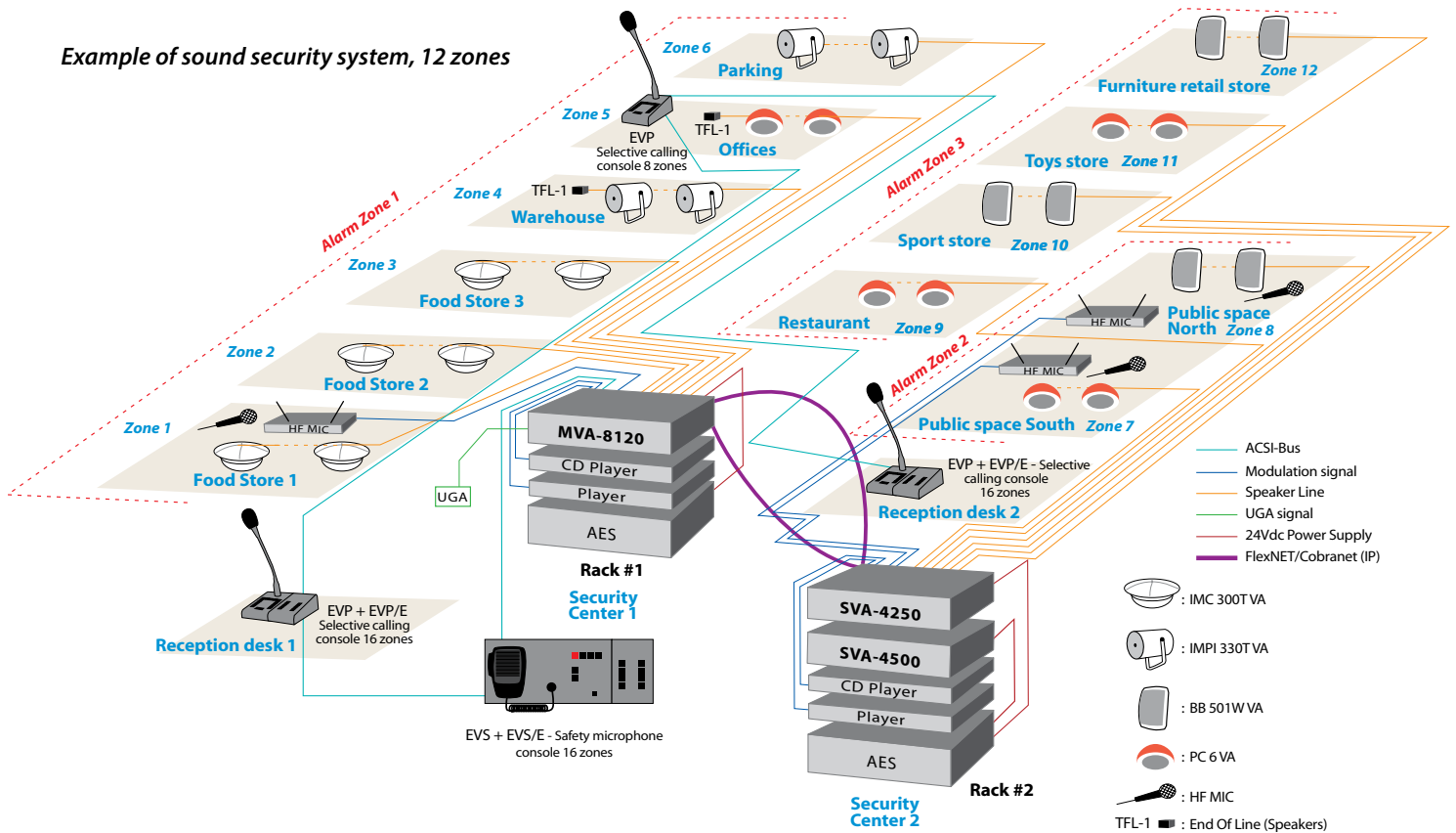

More than a compliant solution..

TOTAL FREEDOM OF ACTION

EXEO is a compact system whose numerous functionalities are easily accessible. You identify the number of administrators required and allocate the appropriate access level to each of them.

EXEO is configured from a PC with the EXEOconfigurator software. The system can be operated locally via the MMI interface thanks to its 4.3" color touch screen on the front panel or remotely from any PC connected to the network via SINEO software.

A TECHNOLOGICAL JEWEL, A LITTLE ERGONOMIC GEM

Equipped with state-of-the-art technology, EXEO also offers you quality ergonomics. Everything, from the 4.3" touch screen to the extremely user-friendly graphical user interface, is

conducive to intuitive navigation. Users can administer what they want, when and how they want.

• Route sources in zones



• Control Inputs, Outputs Amplifiers and Zones Volumes



• Load Presets



• Messages Player



"The highly intuitive interface has been designed to respond to all functions used for the Public Address and Voice Evacuation System"



• Monitoring Inputs/Outputs



• System Configuration

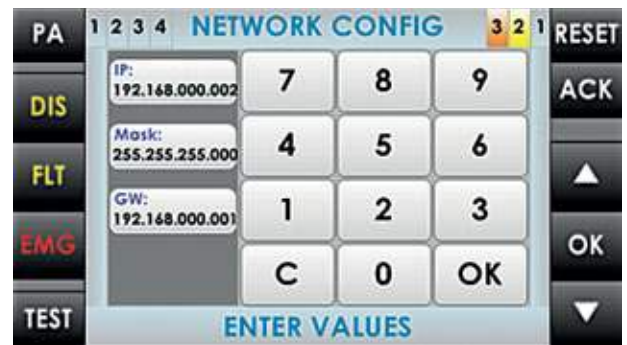

• Disabled Zones Management



• Access Level Management



• Events Logs Emergency/Fault



• Alarm Management / Emergency Calls



A unique system, the most compact on the market

Easy and intuitive remote control



SINEO is a server / client application that allows remote control over the system via TCP / IP. The SINEO interface adapts to the customer's needs: Zone Volume Control, Matrixing, Preset...



Routing source to any zone, manage input levels and volumes zones



Triggering Presets



Manage a Messages Player

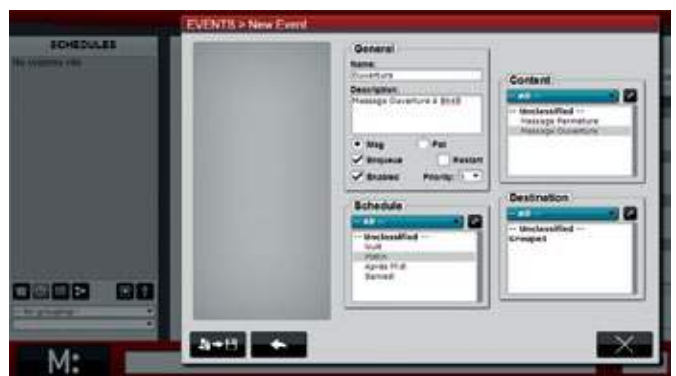

Create/Manage Calendar Events



Access Code Management

Possible to start Evacuations > Messages (Not certified EN54-16)





SINEO can also control a Multi site system with several EXEO Master units.

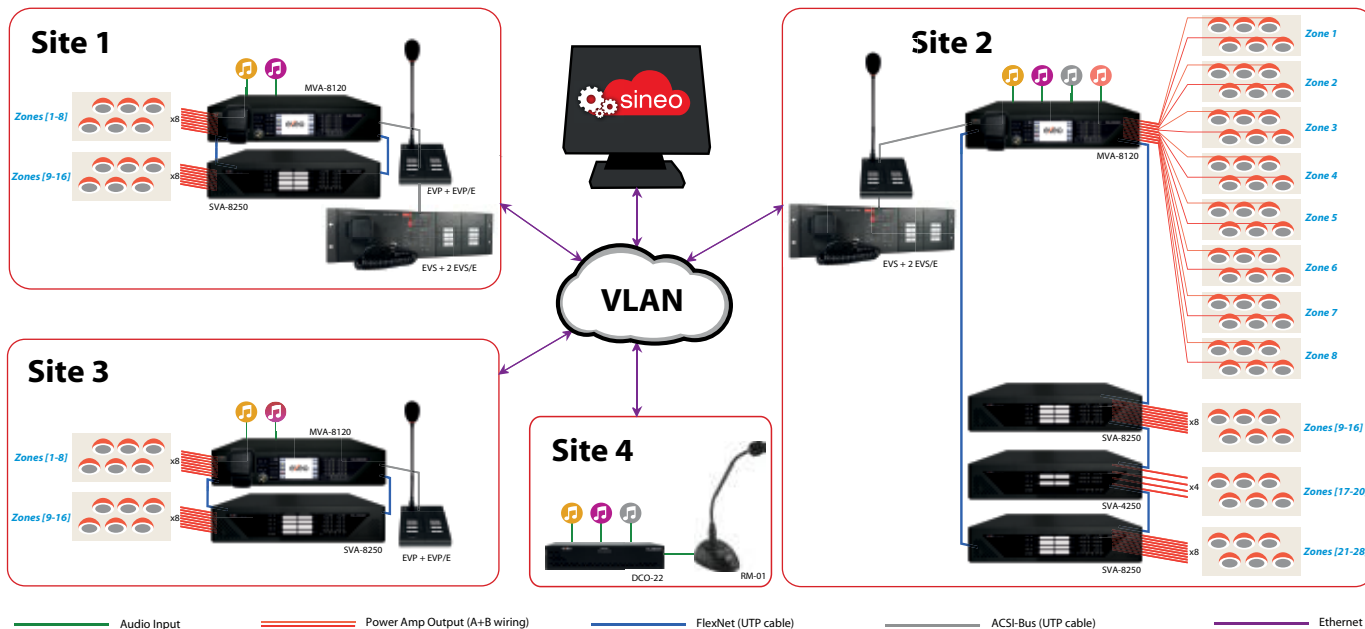

Amplifiers power adapts to your needs !

EXEO is the only system to offer a range of high quality Class D digital amplifiers where the power and the number of channels are distributed according to the needs of the site.

This compact range is made up of 5 models, all in 2U :

- **MVA-8120** : 8 x 120W ou 4 x 240W
- **SVA-4250** : 4 x 250W ou 2 x 500W
- **SVA-4500** : 4 x 500W ou 2 x 1000W
- **SVA-8250** : 8 x 250W
- **SVA-4500L** : 4 x 500W @ 4Ω.



Thus, EXEO can cover any type of installation, from the smallest to the largest, for which high powers are required.

EXAMPLES OF CONFIGURATIONS AND POSSIBLE USES FOR THE MVA-8120

8-Channel Configuration in 120W

OUT	POWER
# 1	120 W
# 2	120 W
# 3	120 W
# 4	120 W
# 5	120 W
# 6	120 W
# 7	120 W
# 8	120 W

4-Channel Configuration in 250W

OUT	POWER
# 1	250 W
# 2	0 W
# 3	250 W
# 4	0 W
# 5	250 W
# 6	0 W
# 7	250 W
# 8	0 W

6-Channel Mixed configuration 120W and 250W

OUT	POWER
# 1	120 W
# 2	120 W
# 3	120 W
# 4	120 W
# 5	250 W
# 6	0 W
# 7	250 W
# 8	0 W

7-Channel Mixed configuration

OUT	POWER
# 1	100 W
# 2	150 W
# 3	200 W
# 4	50 W
# 5	175 W
# 6	75 W
# 7	250 W
# 8	0 W

These amplifiers are protected against short circuits, overheating or earthing.

A reliable source



EVS

MAJORCOM has developed two categories of EXEO consoles: selective calling consoles (EVP) and safety microphone consoles (EVS).

TECHNOLOGY AND ERGONOMICS

As with the EXEO station, the extended range of our consoles – EVP and EVS with extensions – has been designed to respond as accurately as possible to your needs in terms of sound system and evacuation, in compliance with the EN 54-16 standard. They provide excellent speech intelligibility.

Each console is directly connected from the EXEO station via a CAT5/6 cable.



EVP

EVP/E

IN SHORT

- EXEO Microphones consoles can manage up to 64 broadcast zones or 64 alarm zones (Z.A.) on EVS with the addition of EVP/E or EVS/E extensions.
- All Keys can be configured as zone calls, zone groups or to trig messages and presets.
- EVP Stations offer the “recording” function, making possible delayed or repetitive calls.
- Our safety microphones are controlled and monitored by the EXEO. In accordance with the EN 54-16 standard, the link is controlled in open circuits, short circuits and grounded.
- Our consoles are powered by the power supply of the EXEO power unit but can also be powered locally (for EVP).
- Every Call or Alarm Zone key can be configured. Our customer enjoys total usage flexibility.
- LEDs are used to control the chime broadcast, speech and occupation (calling from another console).
- The design optimizes the product’s efficiency and user comfort.



Rackable EVS + 2 EVS/E

EXEO interfaces & accessories

AUDIO INTERFACE

DCO-22 is an audio DSP matrix based on the COBRANET over Ethernet market standards. It has 4 channels of audio input and 4 channels of audio output being these configured by software as channel input or output. It may have up to four channels of input or output so be able to send the audio over Ethernet using the COBRANET Standard.



DCO-22



VCC-64

VOLUME AND CHANNEL CONTROLLER

VCC-64 allows the volume control of the zone where it is located and the routing of audio inputs (channels) from the system to that zone. Unlike an attenuator, VCC-64 has a direct communication with the EXEO system as it uses an RS-485 interface. Up to 8 zones can be controlled in the same bus and several VCC-64 units can be assigned to the same zone.

12VDC POWER SUPPLY FOR VCC-64

The 12VDC **VCC-64PSK** power supply allows the power supply of the Volume and Channel Controller VCC-64 in the system, with a CAT5/6 cable for the entire Bus.



VCC-64PSK



TFL-1

END OF LINE DEVICE [EOL]

The End Of Line Device **TFL-1** provides an accurate measurement of the speakers line impedance in order to test the integrity of the connection between the speakers and the EXEO system. It is a small device very simple to install in 100V or 70V lines.

It has a low power consumption and several devices can be connected to the same speakers line.

The EXEO system allows the Loudspeaker lines to be monitored in two complementary ways, by measuring the line impedance and / or with the end-of-line device TFL-1 (EOL).

A certified range

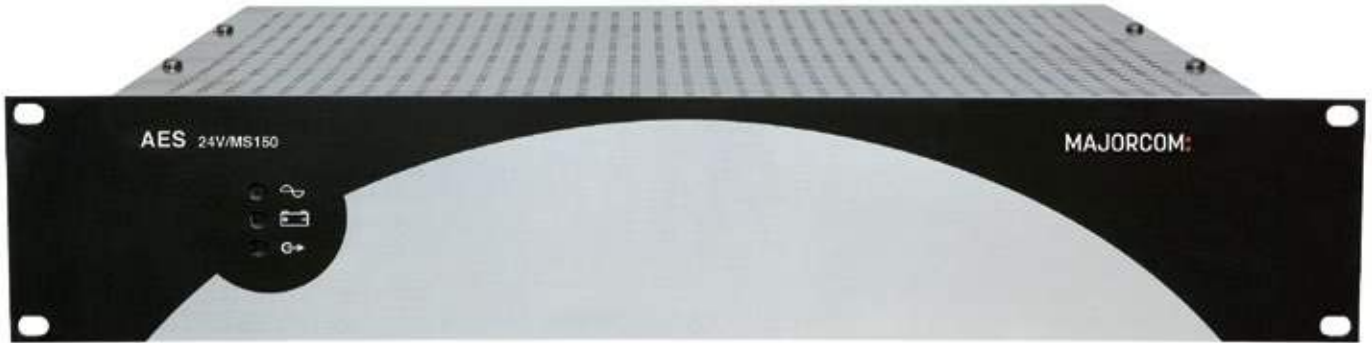

AES 24V/MS150

The EN 54-16 standard, which now governs Sound Security Systems (SSS), refers to the EN 54-4 standard according to which the different Power Supplies of our EXEO System are certified.

Our two BPS models comply with several EC directives: CPD (in compliance with EN 54-4/A2), LVD, EMC, WEEE and RoHS.

AES 24V/MS40: maximum current for all outputs is 40A.

AES 24V/MS150: maximum current for all outputs is 150A.

QUICK AND EASY TO SET UP

- **Simple:** All you need is "1 pair of pliers and 1 screwdriver".
- **Quick:** plug-in connectors on the rear panel. Ready-to-use connection kit.
- **Safe:** a totally sealed box prevents any risk of damaging the internal electronics due to falling conductive parts.
- **Light:** the weight of the 2U rack is 3.1kg for the AES 24V/MS40 and 5.4kg for the AES 24V/M150.

OPTIMAL PERFORMANCE

- **In normal operation mode:** the BPS power supply controls and recharges the batteries and keeps them charged from the mains. It can provide the sound security system with standby current.
- **In security operation mode:** the total operating current (including the current of the amplifiers of the sound security system) is supplied by the batteries.



Example of sound security system, 12 zones + 2 Alarm Zones

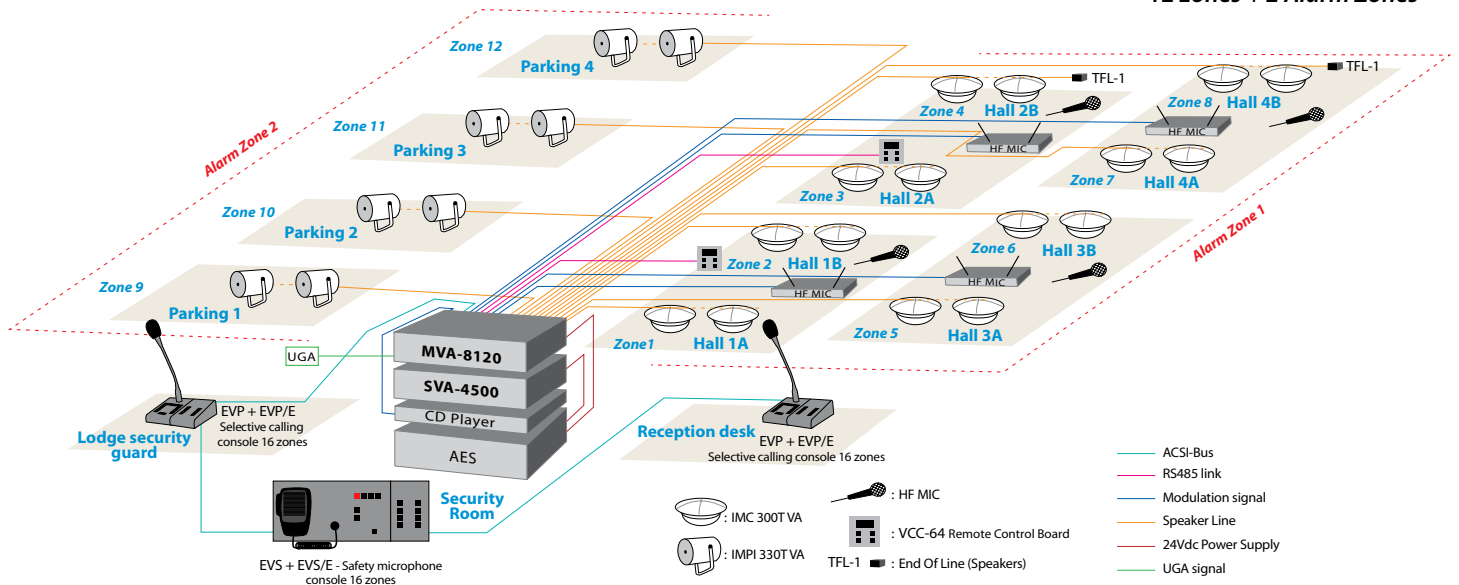



IMC 300T VA

Patented omnidirectionality

Created by MAJORCOM and protected by an international patent, this powerful omnidirectional speaker is specifically adapted to the sound systems of large and very large volumes with loud noise levels: shopping centres, stadiums, sports halls, ice rinks, swimming pools, airports, race courses etc.

Equipped with a heavy-duty, 16cm 2-way speaker (made of fibreglass) and a high-performance 100V line transformer, the IMC 300T VA has a near Hi-Fi quality.

AUDIO QUALITY

It broadcasts quality sound without any frills.

SOUND COVERAGE

The patented reflector has earned the reputation of being the most efficient solution for achieving a large and homogeneous coverage zone (3 to 5 times larger than traditional enclosures, sound projectors etc.).

OPTIMAL INTELLIGIBILITY

RASTI measurements have shown that our products respond in all cases to the intelligibility requirements of safety standard EN-5424 (Type A).

3 steel mounting slings (40cm) make it possible to suspend it securely.



PHS 81T30/8BS

High performance horn speaker

- High performance enclosure
- High-quality vocal reproduction
- Protection from water and dust, IP 66
- EN 54-24 certification

The high-performance horn speaker faithfully reproduces speech with excellent sound distribution and can be used in a wide range of outdoor applications. The perfect solution for sports fields, parks, factories and outdoor pools.

P.A AND VOICE ALARM SPEAKER

PHS 81T30/8BS is designed for use in P.A and Voice Alarm Systems. It meets standards for emergencies (EN 54-24 - Type B). The speaker is equipped with a ceramic terminal block, a thermal fuse and wires that can withstand high temperatures.



Two cable glands and a ceramic terminal block facilitate the installation of all our enclosures, in accordance with the requirements of the EN 54-24 standard.



PC6 VA

Ceiling speaker with fire dome

This recessed ceiling speaker is equipped with a 16cm, 2-way loudspeaker made of fibreglass and a 100V line transformer. It also has a steel cover to prevent fire from spreading across the ceiling.

DYNAMIC SOUND

Its large bandwidth offers remarkable sound quality and perfectly reproduces high and low sounds to take full advantage of music and speech.

COMPLIANT WITH EVACUATION STANDARDS

With its ceramic connection and thermal fuse, the PC6 VA complies with evacuation standards and provides an additional level of safety in case of emergency. This high-quality ceiling light meets the international standards relative to public address and evacuation installations (EN54-24 and ISO 7240-24) (Type A).

EASY INSTALLATION

Its fastening system makes it easy to mount on most ceilings.



CSE 5206EN

Quick-installation ceiling speaker

This ceiling speaker can be used to display messages and to play music. It has a ceramic terminal block and tool-free installation system, making it quick and easy to install. It is perfectly suited for most low-rise buildings with a false ceiling.

IMMEDIATE INSTALLATION

The ceiling speaker is quick and easy to install. Thanks to its patented installation system, it can be attached to the ceiling in a matter of seconds, thereby reducing set-up time.

CSE 5206EN is designed for use in EN 54-24 (Type A) P.A and Voice Alarm Systems.

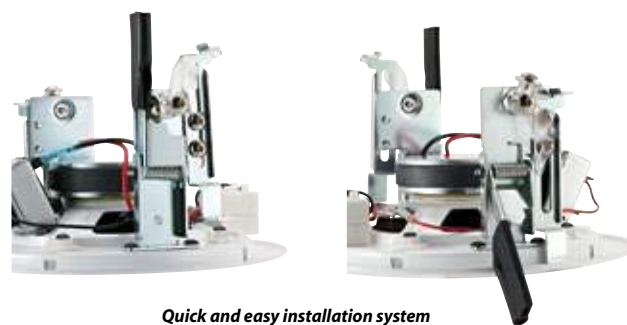

Quick and easy installation system





BB 501 VA

The High Quality, compact wall mount speaker

Ideal for small and moderate volumes (reception halls, restaurants, pubs, conference rooms, shopping centres, swimming pools etc.), this white or black wall speaker guarantees very high-quality sound.

AESTHETICS

Equipped with a compact and robust ABS box, discrete and with an elegant finish, it blends in with all surroundings. Available in White (BB 501 W VA) and Black (BB 501 B VA).

EXCEPTIONAL AUDIO QUALITY

Equipped with a 12cm diameter loudspeaker and a tweeter, its Hi-Fi music quality will satisfy the most demanding listeners.

ADJUSTABLE MOUNTING BRACKET

The enclosures can be mounted horizontally to direct the loudspeaker upwards or downwards, or vertically to enable a left and right rotation using a U-shaped wall bracket made of steel (supplied).

This High Quality enclosure meets the international standards relative to public address and evacuation installations EN54-24 and ISO 7240-24 (Type A).



CS 651WTBS

L'enceinte murale adaptée pour un grand nombre d'applications

Recommended in particular for offices and small areas, this wall mount speaker can be used to display messages as well as play music, and blends in well with most types of decor. Excellent performance for the price.

COMPLIANT WITH EVACUATION STANDARDS

With its ceramic connection and thermal fuse, the CS 651WTBS complies with evacuation standards and provides an additional level of safety in case of emergency.

This wall mount speaker meets the international standards relative to public address and evacuation installations EN54-24 (Type A).





IMPI 330T VA

Indoor/outdoor sound projector

Compliant with the international standards relative to public address and evacuation installations (EN54-24 Type B and ISO 7240-24), this sound projector is recommended for the equipment of all types of public places such as train stations, pedestrian streets, car parks etc.

QUALITY SPEECH AND MUSIC REPRODUCTION

Equipped with a 12cm diameter loudspeaker, its frequency response makes it possible to broadcast high-quality music and information messages.

EASY TO INSTALL

A solid aluminium bracket is provided to facilitate the installation and orientation of the projector in almost all positions. It is possible to mount the bracket first and then the sound projector.

WITHSTANDS ALL KINDS OF WEATHER

Made of extruded aluminium, it can be installed indoors or outdoors (IP55) and blends in with most surroundings.



SPJ 52WHBS

Two-way indoor/outdoor sound projector

- Excellent reproduction of voice and music
- Built-in connector and connection cables
- For installation on the ceiling or on the wall
- Protection from water and dust, IP 66
- EN 54-24 (Type B) certification

The SPJ 52WHBS is a powerful, 20-W bi-directional sound projector designed for the high-quality reproduction of voice and music. It can be used inside or outside. The two opposing speakers are perfect for applications such as metro stations, train stations, parking garages, and make it possible to cut the number of speakers in half.

P.A AND VOICE ALARM SPEAKER

The P.A and Voice Alarm speakers are designed specifically for buildings where voice communication systems are regulated. The SPJ 52WHBS is equipped with a ceramic terminal block, a thermal fuse and wires that can withstand high temperatures.





CS 6HT60BS



CS 5HTBS

2-way acoustical horn speakers

The CS 6HT60BS and CS 5HTBS long-range enclosures are equipped with a 2-way system, thereby providing a wide frequency range and high sensitivity, making them ideal for the high-quality reproduction of voice and music.

With their controlled-directivity acoustical horn and two transducers, one for low frequencies and the other for high, these unique rectangular enclosures produce amazingly pure sound.

The horn is waterproof and can be used in high-humidity environments. It is therefore suitable for outdoor use such as sports fields, stadiums, theme parks, exhibition halls and air terminals, as well as for applications used in P.A and evacuation systems. They are EN 54-24 (Type B) certified.

Two cable glands and a ceramic terminal block facilitate the installation of all our enclosures, in accordance with the requirements of the EN 54-24 standard.

Technical specifications

EXEO MVA-8120 station

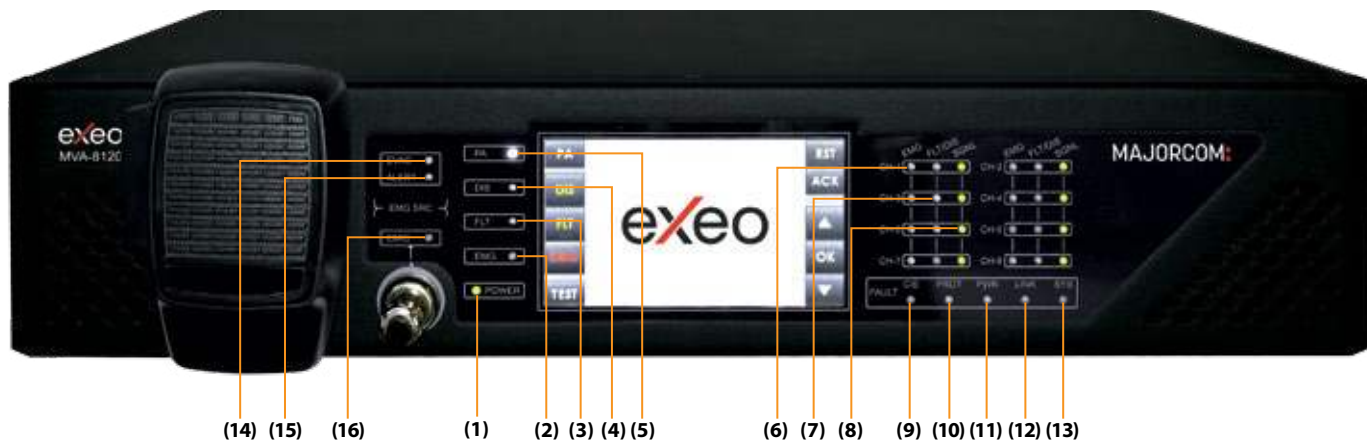

- | | | | |
|------------------------|--------------------------------|-----------------------|-------------------------------|
| (1) Led Power | (6) Led Emergency Channel | (11) Led Power Fault | (16) Led Emergency Microphone |
| (2) Led Emergency | (7) Led Fault/Disarmed Channel | (12) Led Link Fault | |
| (3) Led Fault | (8) Led Signal | (13) Led System Fault | |
| (4) Led Zone Disarmed | (9) Led CIE | (14) Led Evacuation | |
| (5) Led Public Address | (10) Led Protect Amplifier | (15) Led Pre Alert | |

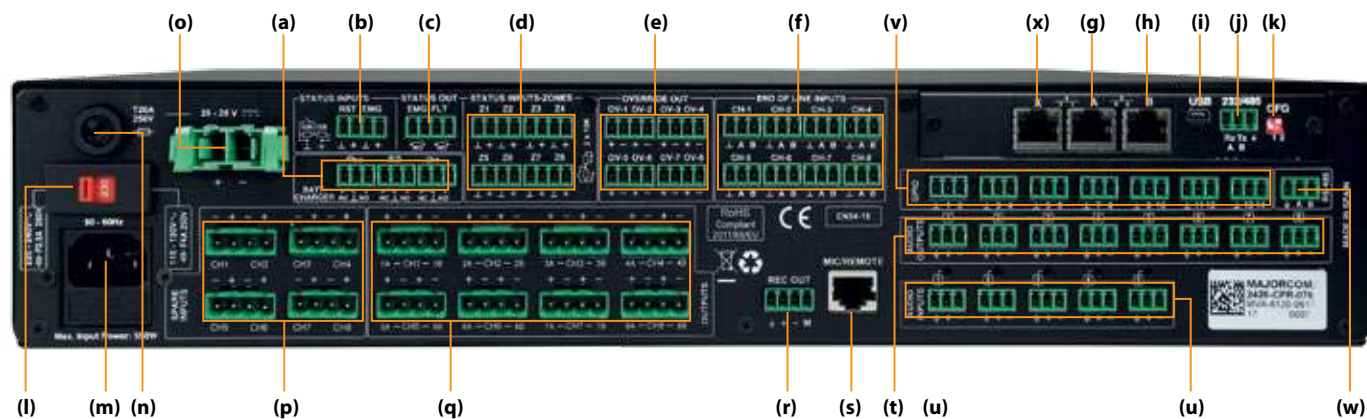

- | | | |
|---|--|--|
| (a) Emergency Power Supervisor Input | (i) USB Port (reserved) | (s) Paging Microphones And System Devices Input ACSI Bus |
| (b) General Emergency Mode Activation Input | (j) Serial Port RS232/485 PA | (t) Audio Line Output (P.A Amplifiers) |
| (c) Status Supervision Outputs | (k) System Connection configuration Switch | (u) Audio Source Input |
| (d) Emergency Zone Mode Activation Input | (l) Main Power supply Switch | (v) Input Output Port GPIO |
| (e) Attenuators Override Output | (m) Main Power supply Input | (w) Emergency Port RS485 |
| (f) End Of Line Inputs | (n) Emergency Power Supply Fuse | (x) Ethernet Port |
| (g) Interface Connection To System A FlexNet / Cobranet | (o) Emergency Power Supply Input 24Vdc | |
| (h) Interface Connection To System B FlexNet / Cobranet | (p) Spare Channels Inputs | |
| | (q) Speaker Line Output | |
| | (r) Record Output | |

EXEO SVA-4250 · SVA-8250 · SVA-4500 · SVA-4500L Extensions



- (1) Led Power
- (2) Led Emergency
- (3) Led Fault
- (4) Led Zone Disarmed
- (5) Led Public Address
- (6) Led Emergency Channel
- (7) Led Fault/Disarmed Channel
- (8) Led Signal
- (9) Led CIE
- (10) Led Protect Amplifier
- (11) Led Power Fault
- (12) Led Link Fault
- (13) Led System Fault

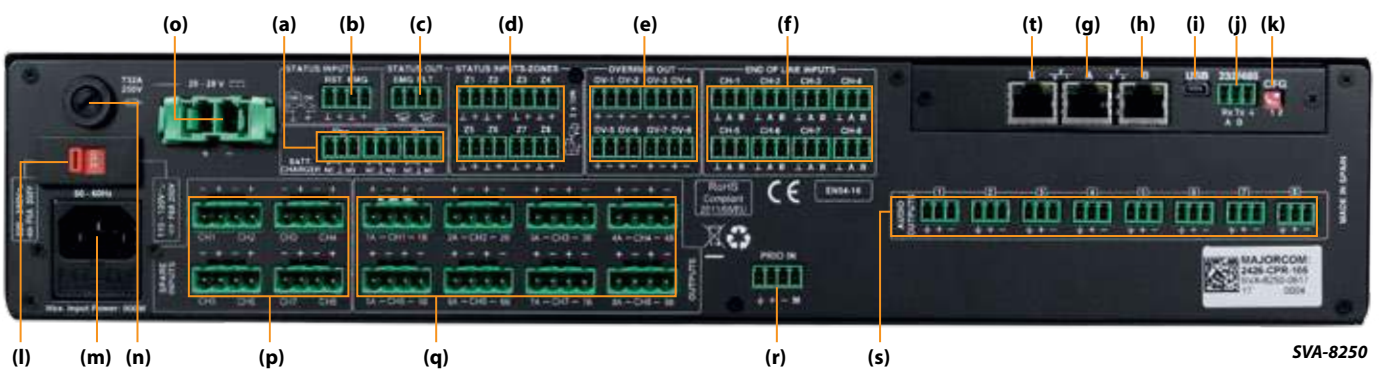
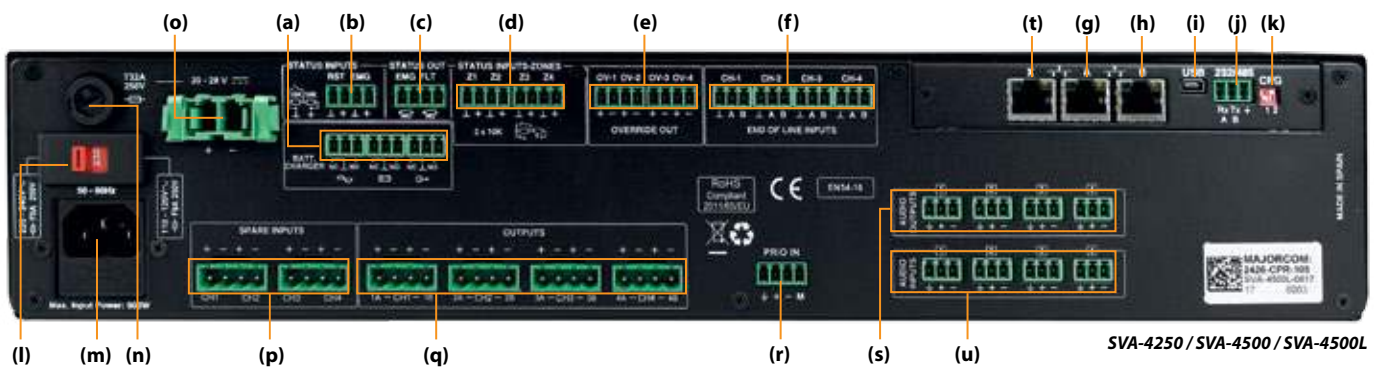

- (a) Emergency Power Supervisor Input
- (b) General Emergency Mode Activation Input
- (c) Status Supervision Outputs
- (d) Emergency Zone Mode Activation Input
- (e) Attenuators Override Output
- (f) End Of Line Inputs
- (g) Interface Connection To System A FlexNet / Cobranet
- (h) Interface Connection To System B FlexNet / Cobranet
- (i) USB Port (reserved)
- (j) Serial Port RS232/485 PA
- (k) System Connection configuration Switch
- (l) Main Power supply Switch
- (m) Main Power supply Input
- (n) Emergency Power Supply Fuse
- (o) Emergency Power Supply Input 24Vdc
- (p) Spare Channels Inputs
- (q) Speaker Line Outputs
- (r) Priority Input (on P.A mode)
- (s) Audio Line Outputs
- (t) Port Ethernet
- (u) Audio Line Balanced Inputs

[only SVA-4500L]

Technical specifications

EXEO station & extensions

EN 54 16

Model	MVA-8120	SVA-8250	SVA-4250	SVA-4500	SVA-4500L
AC Power	115/230Vac 50/60Hz				
Consumption @ 1/8 output power	120W / 550W max	300W / 900W max	260W / 900W max	350W / 900W max	
Frequency response	80 - 20 000 Hz +/-3dB				40 - 20 000 Hz +/-3dB
Signal to noise ratio	> 95dB				
Distortion factor	< 0,05%				
Gain adjustment per channel	-100dB · 0 dB, 1dB Steps				
DSP	Integrated 24 bits 48kHz - 344 MIPS				
FlexNET/Cobranet	3 x FlexNet Redundant (automatic switching)/ Cobranet, Ethernet10/100Mbps. Female RJ-45				
Audio inputs	5 x Balanced audio 7Vrms-0dBV. 10kΩ, 3Pin, Euroblock	Audio Interface DCO-22			4 x Balanced audio 1Vrms-0dBV. 10kΩ, 3Pin, Euroblock
ACSI Bus input	1 x Balanced audio Input 0,7Vrms-0dBV. 10kΩ, RJ45 Female, 800m Maxi	-			
PRI0 audio inputs	-	1 x Balanced audio 0,7Vrms 0dBV. 10kΩ, 3Pin, Euroblock			
Pre-amp Audio Outputs	8 x Balanced audio 0,7Vrms. 100Ω, 3Pin, Euroblock		4 x Balanced audio 0,7Vrms. 100Ω, 3Pin, Euroblock		
REC Out	1 x Balanced audio 0,7Vrms. Sortie 0 - 5Vdc, 4 Pin Euroblock	-			
Attenuators over-ride	8 x Override 24Vdc, 40mA, 2 Pin (4 Pin Euroblock)		4 x Override 24Vdc, 40mA, 2 Pin (4 Pin Euroblock)		
Emergency control inputs	10 x 0-5Vdc, Monitored inputs, 2 Pin (4 Pin Euroblock)		6 x 0-5Vdc, Monitored inputs, 2 Pin (4 Pin Euroblock)		
Emergency control outputs	2 x Relay contact Isolated Output, NO, Max 60Vdc 130mA				
Virtual Audio Matrix	40 x 1024	-			
Port GPIO	14 x Inputs/Outputs 0-5Vdc 3 Pin (4 Pin euroblock)	-			
Class D Amplifiers	8 x Amps 120W (8x60Wrms) / 4 x Amps 250W (120Wrms) @ 70/100V	8 x Amps 250W (8x120Wrms) @ 70/100V	4 x Amps 250W (8x120Wrms) / 2 x Amps 500W (250Wrms) @ 70/100V	4 x Amps 500W (4x250Wrms) / 2 x Amps 1000W (500Wrms) @ 70/100V	4 x Amps 250Wrms @ 8Ω / 500Wrms @ 4Ω
Speakers outputs	16 (2x8) 70/100V, 2 Pin (4 Pin Euroblock)		8 (2x4) 70/100V, 2 Pin (4 Pin Euroblock)		
Speakers loop inputs	16 (2x8) No Voltage Contact, 3 Pin euroblock		8 (2x4) CNo Voltage Contact, 3 Pin euroblock		
Back-up amplifiers inputs	1 Input per chanel, for amplifier with equal power				
Protection	Over-temperature, infrasonic, short circuit, slow start-up, overload				
Emergency Power Input	20 - 28 Vdc, 20A Fused, 2 Pin Euroblock	20 - 28 Vdc, 32A Fused, 2 Pin Euroblock			
Emergency Power Status Input	3 x NO - NC, 3 Pin Euroblock				
Display Screen	Tactile TFT 4,3" 480*272	-			
Operating conditions	-5°C à +45°C / 5 à 95% Relative humidity (No condensation)				
Weight	12kg	14kg	8kg		
Dimensions	483 x 88 x 455mm				
IP Protection	IP30				
Accessories	2 Equerres de rackage, Connecteurs Euroblocks Males, A cable Secteur 2m, 1 Cable Ethernet 2m				

EXEO microphone consoles

Selecting calling consoles



EVP EVP/E

Safety microphone consoles



EVS EVS/E

Model	EVP	EVP/E	EVS	EVS/E
Power Supply	4.5- 5.5V DC, 1 x miniUSB type AB	-	4.5- 5.5V DC, 1 x miniUSB type AB	-
Power Consumption	230mA max	40mA max	200mA	40mA max
Frequency Response	200 - 15000Hz (+/-2dB)	-	200 - 12000Hz (+/-2dB)	-
Signal to noise ratio	>98dB	-	>98dB	-
Sensitivity	-43dB (1kHz)	-	-43dB (1kHz)	-
Type	Condenser	-	Dynamic	-
DSP	Integrated 48kHz, 24bits, 172MIPS	-	Integrated 48kHz, 24bits, 172MIPS	-
External microphone input	Unbalanced audio 15mV, 47kΩ, 3Pin, 3.5mm miniJack type for dynamic microphone	-	-	-
ACSI Bus	2 x Identical ACSI ports: Balanced audio 1Vp, 0,7Vrms. 10 KΩ, female RJ-45, Total 1000m.	-	2 x Identical ACSI ports: Balanced audio 1Vp, 0,7Vrms. 10 KΩ, female RJ-45, Total 1000m.	-
Gooseneck/ Cable length	350mm	-	500mm	-
Dimensions w/o gooseneck	86 x 65 x 190mm	86 x 65 x 190mm	259 x 132 x 50mm	86 x 132 x 50mm
Operating conditions	-5 to +45°C / 5% à 95% Relative Humidity (no condensation)			
Weight	1 kg			
Accessories	1 x miniUSB AB male to USB A male 1 cable CAT5 2m 1 x Pop filter 1x Power Supply USB connector Type C	-	1 x miniUSB AB male to USB A male 1 cable CAT5 2m 2 x accessories for rack installation 1x Power Supply USB connector Type C 1 x block accessory for wall instalation	-

EVP Rear panel



EVS Rear panel



Technical specifications

EXEO interfaces & accessories



Model	DCO-22
Power source	110 - 240V ~ 50/60Hz
Consumption	<20W
Phantom power supply	12V (in all inputs, configurable)
Frequency response I/O	20Hz-20kHz +/-0,05dB
Input sensibility	1Vp, 0,707Vrms
Audio input	Analog, balanced
Sensibility adjustment	+20dB / 0dB / -10dB
S/N	>94dB @1Vrms
Audio Connectors	Euroblock connector
DSP Resolution	48kHz 24bits
GPIO	16 I/O configurable TTL 5V
Ethernet y Cobranet Interface	2 x RJ-45. Redundant
ATT output	24V 50mA, Monitored and protected
Weight	1kg
Processing unit dimensions	218 x 155 x 42mm (1U height, width ½ rack unit)
Finish	Black RAL9005



Model	TFL-1
Light indicator	Activation (red color)
Input	100V or 70V PA line input, Max. consumption 15mA, 2 Pin Euroblock type (orange color)
Output	Isolated contact closure output, NC, Max. 60V DC 130mA, 2 Pin Euroblock type (green color)
Enclosure	ABS, Black RAL9005
Weight	29g
Dimensions	H 66,3 x W 20 x D 50mm
Accessories	Male Euroblock Connectors



Model	VCC-64
Power source	12V DC
Consumption	1,2W max. (100mA)
Bus	RS-485 connects to the System's interface, Max. communication distance is 1200m (Max.. distance to power source is 500m) 4P Terminal Board.
Address setting	DIP switch
Display	2x8 characters LCD
Environmental Conditions	Temperature -5 to 55°C, relative humidity 15%-80%. Anti-interference, confirms EN 55103-2, CE, CCC certified.
Dimensions (WxHxD)	86 x 56 x 40mm
Appearance	ABS Material, White
Weight	110g

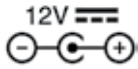

Model	VCC-64PSK
Marking	12V 
Description	12V power source
Type	Input
Signals	+ -
Activation	12VDC, 1 to 1.5 A



(1) : LED Power Default (2) : LED Battery Default (3) : LED Output Voltage Default

Model	AES 24V/MS 40	AES 24V/MS 150
Power voltage	195 - 264vAC, 50-60Hz	
Primary Current	1 A @ 195vAC	2 A @ 195vAC
	Breaker Circuit (D curve) need to be provided Upstream	
Outputs	Nominal Voltage 24vDC Floating Voltage Set at half-load and at 25°C: 27.2V +/- 0.5%	
	2 "Amplifiers" Outputs with a current of 20A maximum per Output on connectors 16mm ² 2 "Controllers" Outputs with a current of 5A maximum per Output on connectors 2.5mm ² The maximum current for all outputs is 40A	6 "Amplifiers" Outputs with a current of 40A maximum per Output on connectors 16mm ² 3 "Controllers" Outputs with a current of 5A maximum per Output on connectors 2.5mm ² The maximum current for all outputs is 150A
Outputs Relays	Output Relay without any voltage Battery Default Output Relay without any voltage Main Power Default Output Relay without any voltage 24V Output Default	
Battery Capacity	Between 24 and 110Ah	Between 38 and 225Ah
Operating Temperature	-10 to +45°C at 100% of load -10 to +55°C at 75% of load	
Relative Humidity	20 to 95%	
Dimensions (WxDxH)	483 x 395 x 89mm	
Weight	3.1kg	5.4kg



AES 24V/MS40 rear panel



AES 24V/MS 150 rear panel



IMC 300T VA

PC6 VA

CSE 5206EN

Horizontal directivity

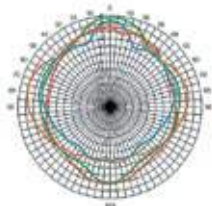

Horizontal directivity

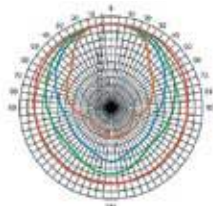

Directivity

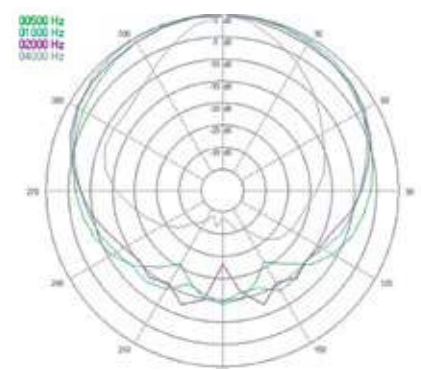

500 Hz
1 kHz
2 kHz
4 kHz

Vertical directivity

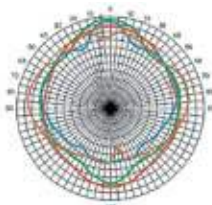

500 Hz
1 kHz
2 kHz
4 kHz

Vertical directivity

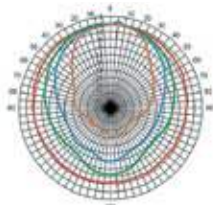

Bandwidth

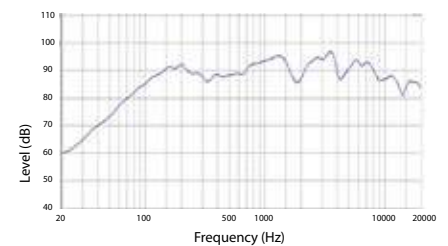

Bandwidth

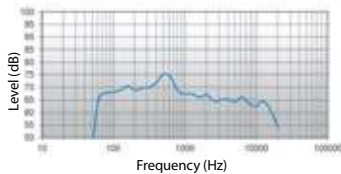

Bandwidth

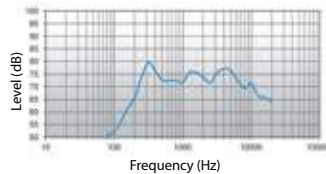

Model	IMC 300T VA	PC6 VA	CSE 5206 EN
Body & grill	Metal	Metal	Metal
Power nominal	10W	12W	6W
Impedance nominal	1000Ω	830Ω	1667Ω
Power 100V line	10W	12 / 6 / 3 / 1.5W	6 / 3 / 1,5W
Impedance	1000Ω	830 / 1600 / 3300 / 6600Ω	1667 / 3333 / 6667Ω
Bandwidth	60Hz - 20kHz	160Hz - 20kHz	80Hz - 20kHz
Sensitivity (1W/1m)	83dB	87dB	92dB
SPL MAX 1m	93dB	97dB	99dB
Directivity (H-V) @ 500Hz	360° - 360°	215° - 360°	160°
Directivity (H-V) @ 1kHz	360° - 360°	140° - 155°	150°
Directivity (H-V) @ 2kHz	200° - 200°	94° - 102°	150°
Directivity (H-V) @ 4kHz	330° - 275°	70° - 70°	40°
Speaker	16cm - 2 ways	16cm - 2 ways	5"
Cone	Fiberglass	Fiberglass	Paper composite
Dimensions (mm)	∅480/∅370 x (H)260	∅230 x (H)155 (fitting size ∅207)	∅183 x (H)97,5
Weight	4.5kg	1.8kg	1kg
Type: (A) Indoor (B) Outdoor	A	A	A
Operating temperature	-15 to +55°C	-15 to +55°C	-10 à +55°C
Protection index	IP54	IP33	IP21

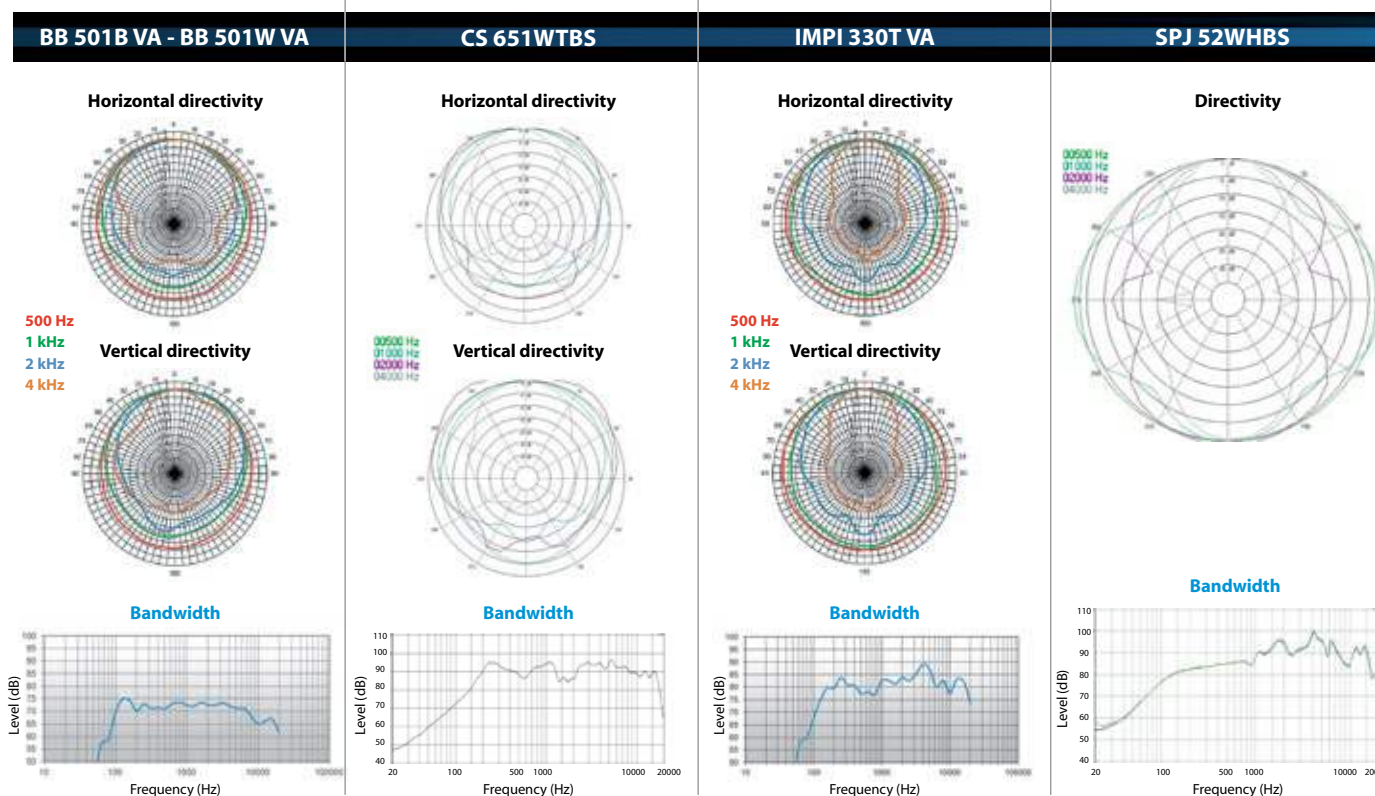

Model	BB 501B VA - BB 501W VA	CS 651WTBS	IMPI 330T VA	SPJ 52WHBS
Body & grill	ABS metal	ABS fireproof - Steel	Aluminium	Aluminium
Power nominal	24W	6W	10W	20W
Impedance nominal	416Ω	1667Ω	1kΩ	500Ω
Power 100V line	24 / 12 / 6W	6 / 3 / 1,5W	10 / 5 / 2,5W	20 / 10 / 5W
Impedance	416 / 833 / 1600Ω	1667 / 3333 / 6667Ω	1 / 2 / 4kΩ	500 / 1000 / 2000Ω
Bandwidth	63Hz - 20kHz	150Hz - 20kHz	120Hz - 20kHz	120Hz - 20kHz
Sensitivity (1W/1m)	85dB	92dB	95dB	88dB
SPL MAX 1m	98dB	99dB	103dB	100dB
Directivity (H-V) @ 500Hz	210° - 190°	180° - 180°	360° - 360°	360°
Directivity (H-V) @ 1kHz	195° - 165°	120° - 150°	240° - 260°	320°
Directivity (H-V) @ 2kHz	98° - 124°	150° - 180°	115° - 115°	200°
Directivity (H-V) @ 4kHz	77° - 77°	40° - 70°	54° - 54°	80°
Speaker	12cm	6.5"	12cm	2 x 5"
Cone	Plastic	Paper composite	Plastic	
Dimensions (mm)	(W)200 x (D)155 x (H)261	(L)204,5 x (P)87,5 x (H)254,5	Ø138 x (D)225	Ø 146 x 186
Weight	1.7kg	1,6kg	2.5kg	3,2kg
Type: (A) Indoor (B) Outdoor	A	A	B	B
Operating temperature	-15 to +55°C	-10 à +55°C	-25 to +70°C	-20 à +70°C
Protection index	IP55	-	IP55	IP66



PHS 81T30/8BS

CS 6HT60BS

CS 5HTBS

Directivity

Horizontal directivity

Horizontal directivity

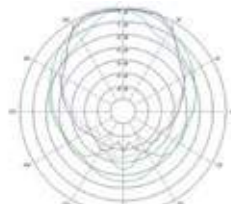
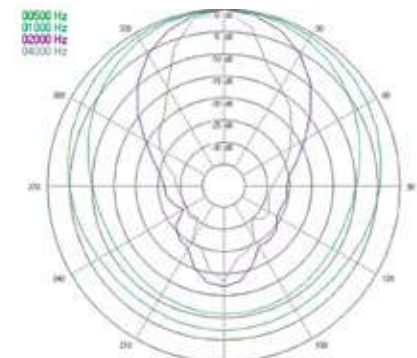

Vertical directivity

Vertical directivity

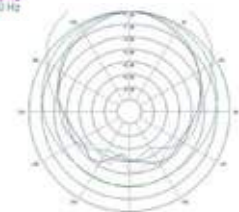
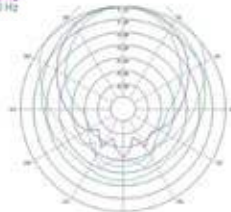

Bandwidth

Bandwidth

Bandwidth

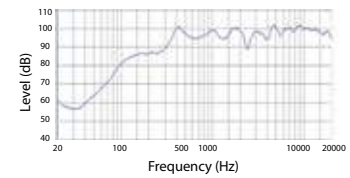
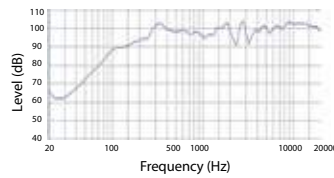
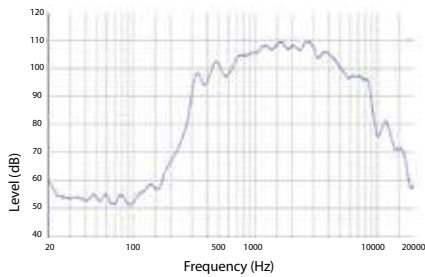

Model	PHS 81T30/8BS	CS 6HT60BS	CS 5HTBS
Body & grill	ABS fireproof	ABS fireproof	ABS fireproof
Power nominal	30W	60W	30W
Impedance nominal	333Ω	167Ω	333Ω
Power 100V line	30 / 15 / 7,5 / 3,75W	60 / 30 / 15 / 7,5W	30 / 15 / 7,5 / 3,75W
Impedance	333 / 666 / 1333 / 2667Ω	167 / 333 / 666 / 1333Ω	333 / 666 / 1333 / 2667Ω
Bandwidth	340Hz - 9kHz	100Hz - 20kHz	120Hz - 20kHz
Sensitivity (1W/1m)	108dB	98dB	96dB
SPL MAX 1m	123dB	113dB	111dB
Directivity (H-V) @ 500Hz	200°	100° - 140°	140° - 180°
Directivity (H-V) @ 1kHz	120°	40° - 70°	60° - 100°
Directivity (H-V) @ 2kHz	60°	80° - 90°	90° - 90°
Directivity (H-V) @ 4kHz	30°	80° - 150°	90° - 140°
Speaker	8"	6" + 2,5" driver	6" + 2,5" driver
Dimensions (mm)	Ø 212 x 280	(L)332 x (P)391 x (H)418	(L)315 x (P)355 x (H)215
Weight	2,1kg	7,05kg	4,65kg
Type: (A) Indoor (B) Outdoor	B	B	B
Operating temperature	-20 à +70°C	-25 à +70°C	-25 à +70°C
Protection index	IP66	IP66	IP66

Qualifications & certifications

From the station to peripheral devices, our EXEO solution strictly complies with the requirements of European EN 54 and international ISO standards. These certifications, genuine proof of quality and reliability, give you total peace of mind while ultimately guaranteeing the safety of the public concerned.



The EC marking of our products guarantees compliance with the European regulation in terms of safety, health and environmental protection while ensuring their free circulation within the European Union.



stands for "Restriction of the use of certain Hazardous Substances in electrical and electronic equipment". Our products respect the RoHS European directive (2002/95/EC), the purpose of which is to limit the use of certain heavy metals and other harmful materials.



Our **EN-54** products comply with European safety requirements in terms of fire detection and alarm systems.



EN 54-16 concerns the voice alarm control and indicating equipment.



EN 54-24 concerns the components of voice alarm systems (Loudspeakers).

EN 54-4 concerns the power supply equipment.



Our **ISO 7240** products comply with International safety requirements in terms of fire detection and alarm systems.

ISO 7240-24 concerns the components of voice alarm systems (Loudspeakers).



CobraNet is a combination of software, hardware, and network protocols designed to deliver uncompressed, multi-channel, low-latency digital audio over a standard Ethernet network.



MAJORCOM is ISO 9001 certified

The ISO 9001:2008 certification of the quality management system demonstrates MAJORCOM's commitment to delivering a quality service and satisfying its customers while constantly improving its quality management systems. The award of an ISO 9001:2008 certificate by a prestigious company like BUREAU VERITAS is proof of high quality and also demonstrates that MAJORCOM complies with the quality management principles recognised at the highest international level.

MAJORCOM, rock-solid reliability



Vast expertise in professional sound systems

For 4 decades, we have provided our partners with systems adapted to their actual technical and economic needs in the safety domain: sound systems and CCTV. We are involved in the tertiary, institutional and sport sectors and work with high-profile European brand names.

A company you can rely on

Our success and reputation as a technically reliable and available partner have made us a major and recognised player on the national and international market of professional sound systems. We are proud of the confidence our specifiers, installers and integrators have placed in us and we are doing our utmost to maintain this trust.



A strong structure

MAJORCOM strives to remain a company with a human dimension, available to all its partners. We would like to give you our full support in the identification, understanding and realization of all your projects and assure you the greatest peace of mind.

An expert and committed technical team, ready to provide you with all the support you need.

< **MAJORCOM'S PLUSSES** >

Specific innovations achieved by MAJORCOM's Research & Development, to promote safety.

MAJORCOM:



:SOUND

:SECURITY

:VISUAL

www.majorcom.fr

56, chemin de la Flambère - 31300 Toulouse - France
Tél. + 33 5 61 31 86 87 • Fax + 33 5 61 31 87 73 • commercial@majorcom.fr